

INSTALLATION INSTRUCTIONS

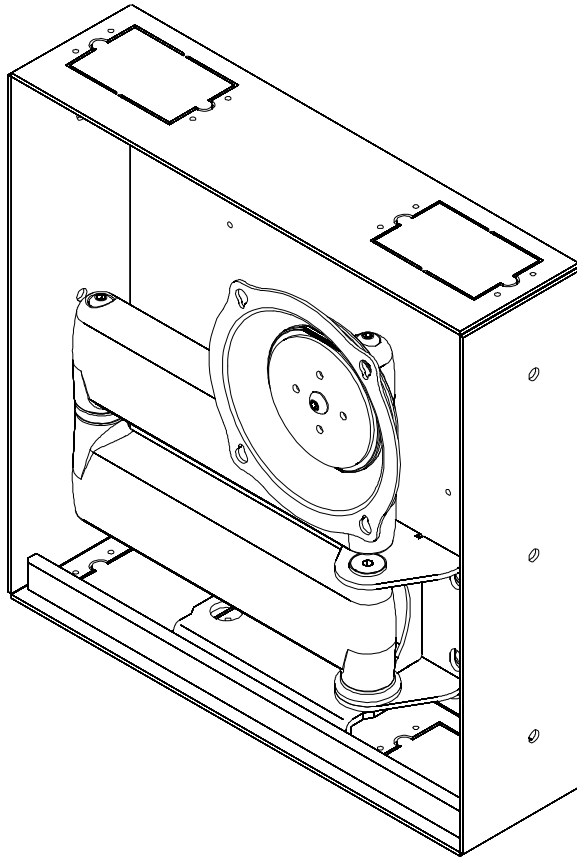

IN-WALL ENCLOSURE

DISCLAIMER

CSAV, Inc., and its affiliated corporations and subsidiaries (collectively, "CSAV"), intend to make this manual accurate and complete. However, CSAV makes no claim that the information contained herein covers all details, conditions or variations, nor does it provide for every possible contingency in connection with the installation or use of this product. The information contained in this document is subject to change without notice or obligation of any kind. CSAV makes no representation of warranty, expressed or implied, regarding the information contained herein. CSAV assumes no responsibility for accuracy, completeness or sufficiency of the information contained in this document.

! IMPORTANT WARNINGS AND CAUTIONS!

! WARNING: A WARNING alerts you to the possibility of serious injury or death if you do not follow the instructions.

! CAUTION: A CAUTION alerts you to the possibility of damage or destruction of equipment if you do not follow the corresponding instructions.

! WARNING: Failure to read, thoroughly understand, and follow all instructions can result in serious personal injury, damage to equipment, or voiding of factory warranty! It is the installer's responsibility to make sure all components are properly assembled and installed using the instructions provided.

! CAUTION: This equipment must be installed and assembled by qualified service personnel in accordance with local building codes.

! WARNING: Failure to provide adequate structural strength for this accessory can result in serious personal injury or damage to equipment! It is the installer's responsibility to make sure the structure to which this accessory is attached can support the combined weight of the box and all equipment not to exceed 75 lbs (34.02 kg).

DIMENSIONS

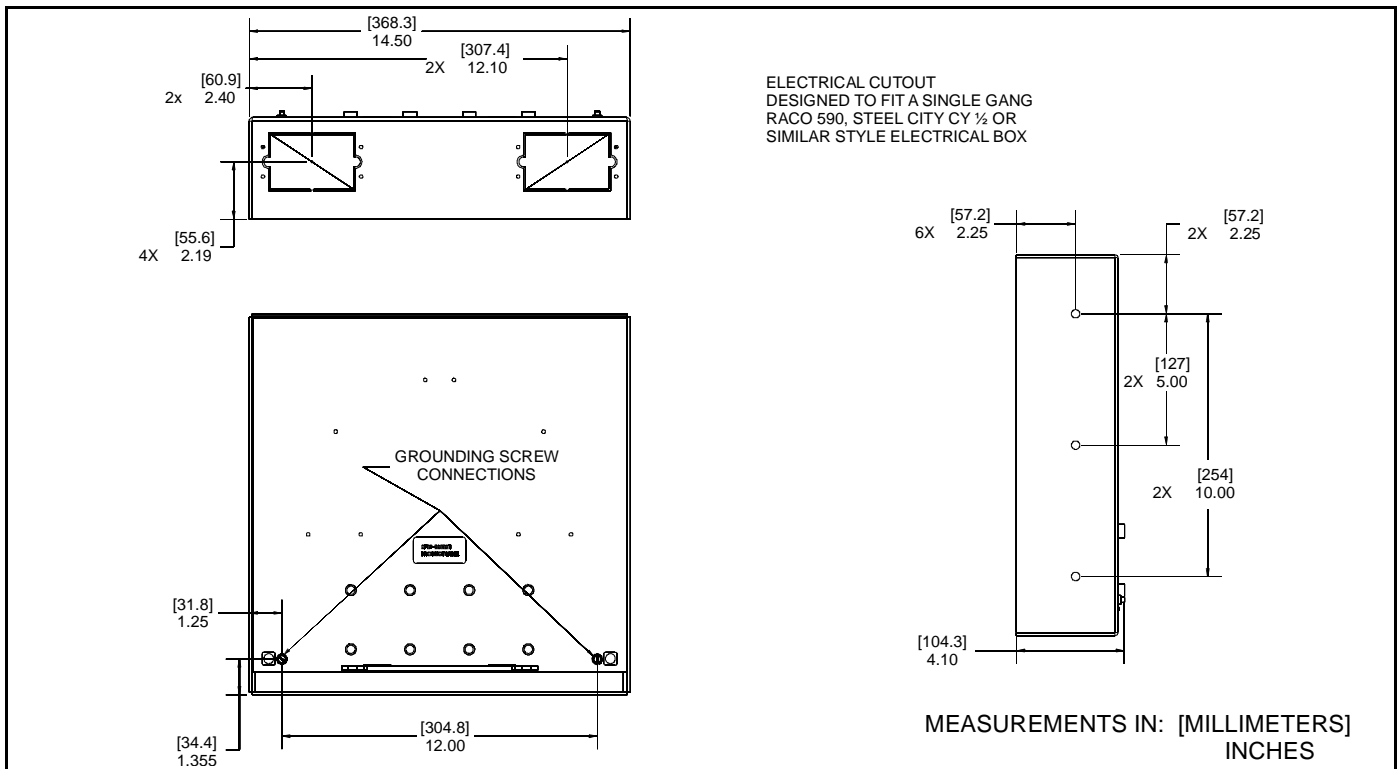



LEGEND

	Tighten Fastener
	Apretar elemento de fijación
	Befestigungsteil festziehen
	Apertar fixador
	Serrare il fissaggio
	Bevestiging vastdraaien
Serrez les fixations	

	Pencil Mark
	Marcar con lápiz
	Stiftmarkierung
	Marcar com lápis
	Segno a matita
	Potloodmerkten
Marquage au crayon	

	Loosen Fastener
	Aflojar elemento de fijación
	Befestigungsteil lösen
	Desapertar fixador
	Allentare il fissaggio
	Bevestiging losdraaien
Desserrez les fixations	

	Drill Hole
	Perforar
	Bohrloch
	Fazer furo
	Praticare un foro
	Gat boren
Percez un trou	

	Phillips Screwdriver
	Destornillador Phillips
	Kreuzschlitzschraubendreher
	Chave de fendas Phillips
	Cacciavite a stella
	Kruiskopschroevendraaier
Tournevis à pointe cruciforme	

	Adjust
	Ajustar
	Einstellen
	Ajustar
	Regolare
	Afstellen
Ajuster	

	Open-Ended Wrench
	Llave de boca
	Gabelschlüssel
	Chave de bocas
	Chiave a punte aperte
	Steeksleutel
Clé à fourche	

	Remove
	Quitar
	Entfernen
	Remover
	Rimuovere
	Verwijderen
Retirez	

	By Hand
	A mano
	Von Hand
	Com a mão
	A mano
	Met de hand
À la main	

	Optional
	Opcional
	Optional
	Opcional
	Opzionale
	Optie
En option	

	Hex-Head Wrench
	Llave de cabeza hexagonal
	Sechskantschlüssel
	Chave de cabeça sextavada
	Chiave esagonale
	Zeskantsleutel
Clé à tête hexagonale	

	Security Wrench
	Llave de seguridad
	Sicherheitsschlüssel
	Chave de segurança
	Chiave di sicurezza
	Veiligheidssleutel
Clé de sécurité	

TOOLS REQUIRED FOR INSTALLATION

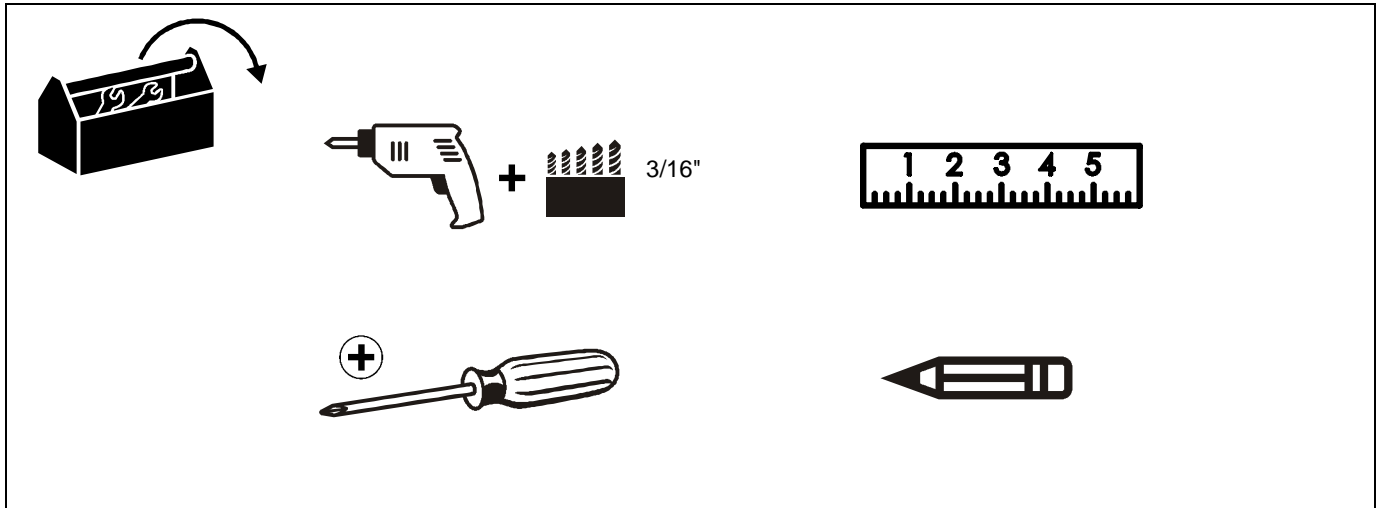

PARTS

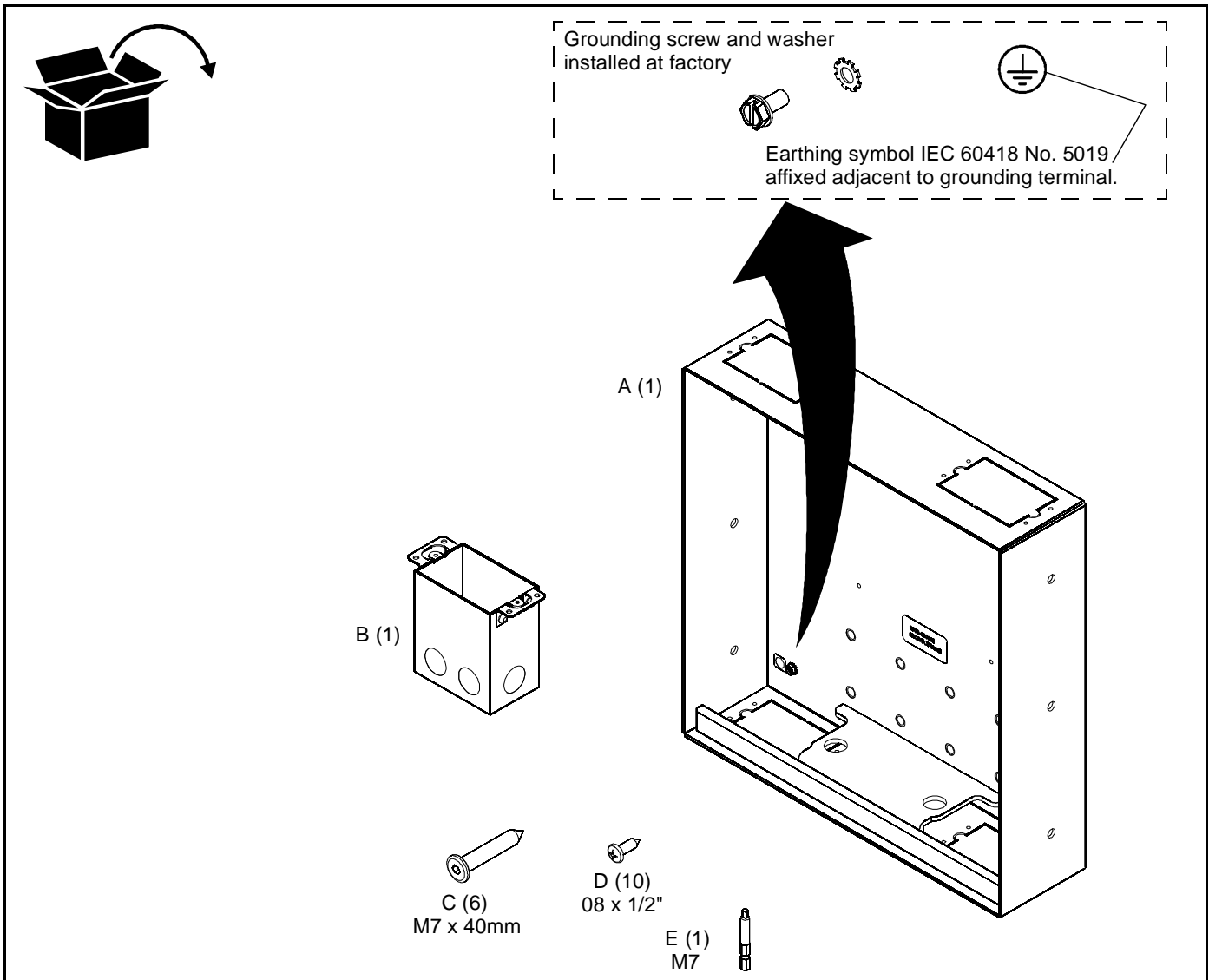

INSTALLATION



WARNING: IMPROPER INSTALLATION CAN RESULT DEATH OR SERIOUS PERSONAL INJURY! This accessory should be installed by qualified personnel.

Site Preparation

Locate and Prepare Mounting Site

1. Identify a suitable wall location for the in-wall enclosure.

IMPORTANT ! : The MAC-501 is designed for in-wall installation between two wood studs, 16" on center. Inadequate space will remain on each side between studs for electrical wires/cables, plumbing, ductwork, or insulation. Locate accordingly!



WARNING: ELECTRICAL SHOCK HAZARD! CUTTING OR DRILLING INTO ELECTRICAL WIRES OR CABLES CAN CAUSE DEATH OR SERIOUS PERSONAL INJURY! ALWAYS make certain area behind mounting surfaces is free of electrical wires and cables before cutting, drilling, or installing fasteners.



WARNING: EXPLOSION AND FIRE HAZARD! CUTTING OR DRILLING INTO GAS PLUMBING CAN CAUSE DEATH OR SERIOUS PERSONAL INJURY! ALWAYS make certain area behind mounting surfaces is free of gas, water, waste, or any other plumbing before cutting, drilling, or installing fasteners.

2. Using a stud sensor, locate and mark studs.
3. Center and level housing between marked studs.
4. Using housing as a template, draw pencil line completely around housing.

NOTE: Housing is designed to fit between and directly against two adjacent wall studs.

5. Cut drywall on *outside* edge of line and remove.

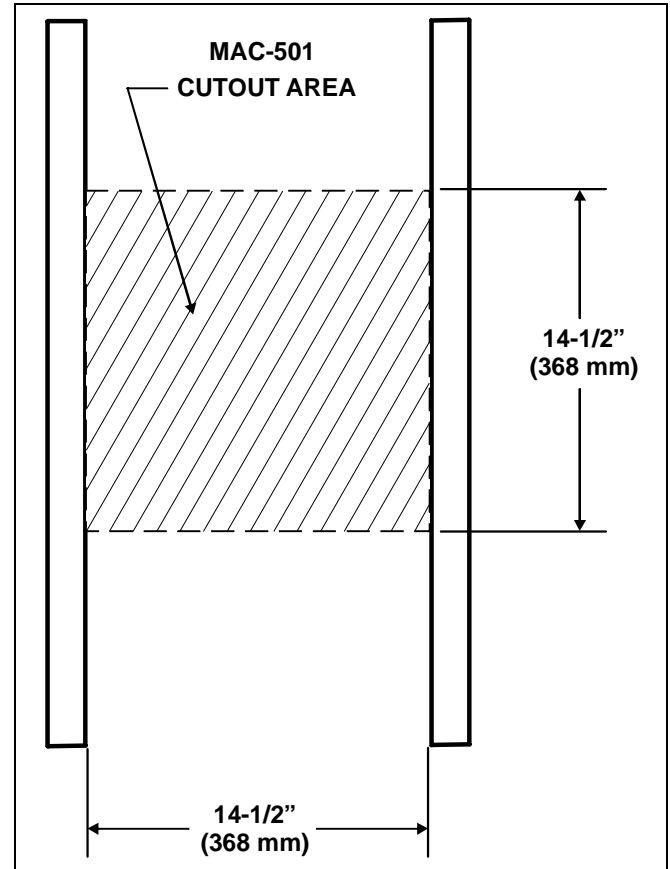

Figure 1

In-Wall Enclosure Installation

1. Install junction box (B) into the MAC-501 (A) using four 08 x 1/2" Phillips pan head tap screws (D). (See Figure 2)

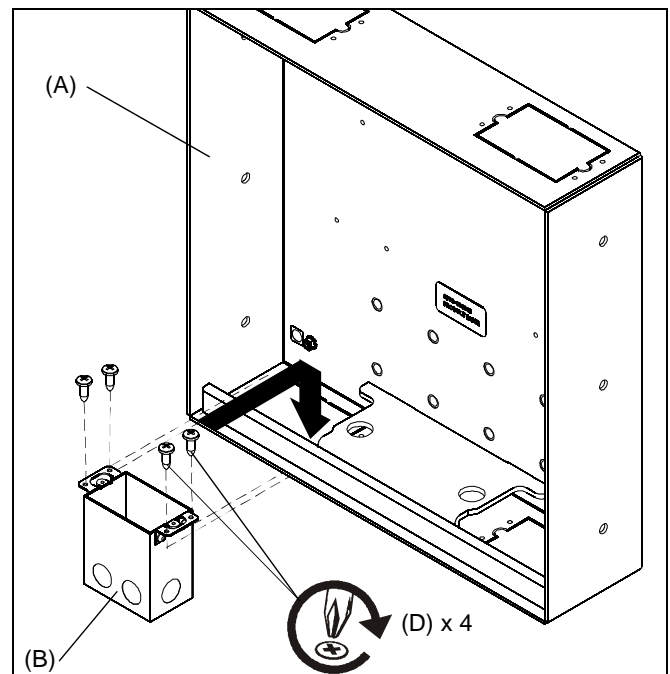

Figure 2

2. Connect electrical wiring.
3. Route audio/visual cables into housing.
4. Center MAC-501 in opening and insert into opening. Align front of box with front face of wall. (See Figure 3)

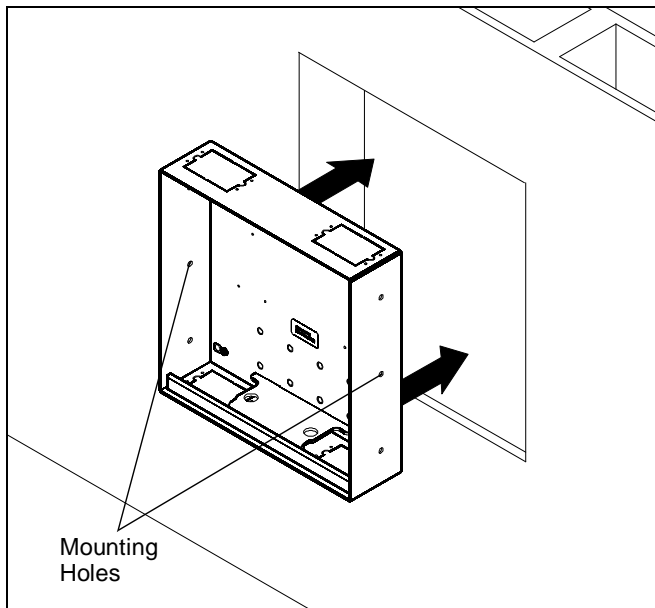

Figure 3



WARNING: ELECTRICAL SHOCK HAZARD! CUTTING OR DRILLING INTO ELECTRICAL WIRES OR CABLES CAN CAUSE DEATH OR SERIOUS PERSONAL INJURY! ALWAYS make certain area behind mounting surfaces is free of electrical wires and cables before cutting, drilling, or installing fasteners.

5. Drill six 3/16" diameter pilot holes in studs at mounting holes.
6. Attach the MAC-501 using six M7 x 40mm Allen head connector screws into pilot holes using an M4 Allen head drill bit (E).



DANGER: IMPROPER WIRING CAN LEAD TO DEATH OR SEVERE PERSONAL INJURY! Grounding must be installed by qualified personnel using a UL Recognized No. 12AWG Green and Yellow grounding wire connected to grounding lug on mount.

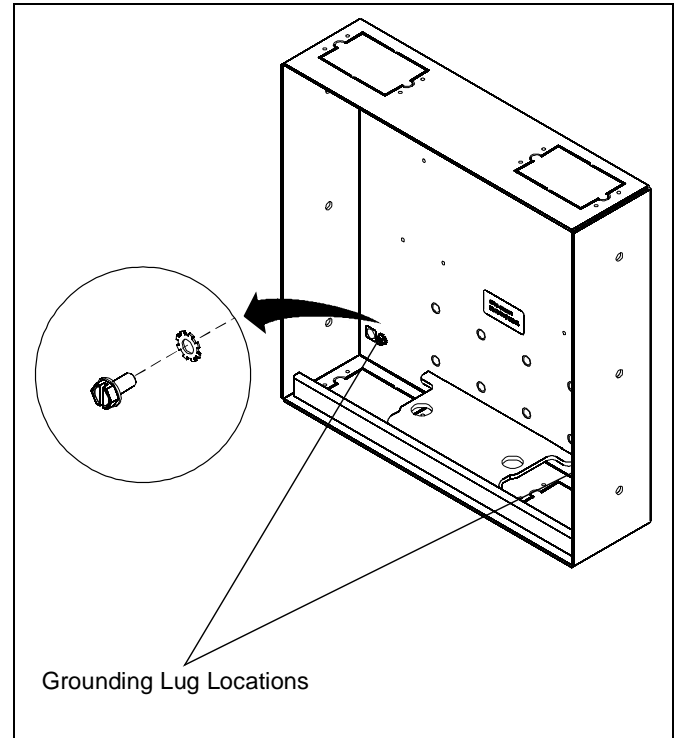

Figure 4

Installing Arm Kit

Install arm kit following instructions included with the kit.



8807-000072
©2007 Chief Manufacturing
www.chiefmfg.com
10/07

USA/International	A 8401 Eagle Creek Parkway, Savage, MN 55378 P 800.582.6480 / 952.894.6280 F 877.894.6918 / 952.894.6918
Europe	A Fellenoord 130 5611 ZB EINDHOVEN, The Netherlands P 31 (0)20 5708923 F 31 (0)20 5708989
Asia Pacific	A Room 30I, Block D, Lily YinDu International Building LuoGang, BuJi Town, Shenzhen, CHINA. Post Code: 518112 深圳市布吉罗岗百合银都国际大厦D栋30I P +86-755-8996 9226 ; 8996 9236 ; 8996 9220 F +86-755-8996 9217