



## FiberLink 3380 Series



**3G/HD/SD-SDI Transmission  
and Analog Audio Embedding  
over one single mode or  
multimode fiber**

**Installation and Operations  
Manual**

## Contents

Welcome .....	3
Features .....	3
Package Contents .....	3
Technical Specifications	
Model Part Number Specifications .....	4
General Specifications .....	4
Transmitter Specifications .....	4
Audio Specifications .....	5
Receiver Specifications .....	6
Operating Loss Budgets & Maximum Usable Distance .....	7
Alarm Switch Settings .....	7
Installation Instructions .....	8
Audio Introduction .....	9
Audio Input/Output TASCAM DB-25 Audio Connector Pin Out .....	10
Product Photos .....	11
Audio Configuration .....	12
Indicator LEDs .....	14
Operating Pointers .....	16
Troubleshooting .....	16
Maintenance and Repairs .....	17
Certifications .....	17
Accessories and Related Products .....	18

## Welcome

Thank you for purchasing Artel Video Systems' FiberLink 3380 Series. The 3380 Series is used to transmit 3G/HD/SD-SDI over a single fiber optic core and embed up to 4 channels (2 Pairs) of Analog Audio. Alternatively, you can pass previously embedded audio and data as well, or replace previously embedded audio. The FiberLink 3380 series is compatible with single mode or multimode fiber. The 3380 is also compliant with SMPTE 297-2006 for seamless interoperability with other SMPTE 297-2006 devices. The system delivers noise-free transmission that retains all of the signals' initial parameters, regardless of fiber optic cable attenuation. The 3380 Series also provides immunity to video pathological signals over the entire link budget and operating temperature range. The 3380 Series can be used with FiberLink 3360 Series to perform digital to analog or analog to digital audio format conversion.

## Features

- Signal is equalized and re-clocked prior to fiber optic transmission
- Embed up to 4 Channels (2 Pairs) of Analog Audio
- Insert on any audio group
- Selectively choose which audio group to retrieve on the receiver
- Receiver features one re-clocked SDI output and balanced/unbalanced analog audio output
- Designed for fiber optic interoperability with other SMPTE 297-2006 fiber optic compliant devices up to 2.97 Gbps
- Immunity to pathological signals over entire link budget and operating temperature range
- Compliant with SMPTE 424M-2006, 259M-2006, 292-2006, 297-2006
- Supports both Single Mode and Multimode ( 62.5u & 50u) fiber types
- Supports 3G/HD/SD-SDI inputs with or without embedded audio and data.
- 14db Optical Link Budget - 2.97 Gbps
- Wide operating temperature range: -10° C to +50° C
- Available in Box and Card versions
- Designed and Manufactured in the USA by Artel

## Package Contents

- One FiberLink 3380 or 3381
- This User's Manual
- DB-25M with Shell

## Technical Specifications

### Model Part Number Specification

Unit Type	Part Number
Transmitter Box	3380-B7L (LC) 3380-B7S (ST)
Transmitter Rack Card	3380-C7L (LC) 3380-C7S (ST)
Receiver Box	3381-B7L (LC) 3381-B7S (ST)
Receiver Rack Card	3381-C7L (LC) 3381-C7S (ST)

### General Specifications

Indicators	Power, Data Rate lock (3G, HD, SD), Audio Status Alarm (card version only)
Box Version Dimensions	8.1x6.28x1.15 (in) 206x89x30 (mm)
Weight	18.1 ounces, 513 grams
Number of slots in 6000A card cage	2
Power	9-24 volts DC or 24 volts AC 3380: 8.6 Watts, 29.3 BTU/Hr 3381: 10.3 Watts, 35.1 BTU/Hr
Operating Temperature	-10°C to +50°C
MTBF	39,000 Hours

### 3380 Transmitter Specifications:

#### Serial Video BNC Input

Number of Inputs	1
Data Rate Range	270 Mbps to 2.97 Gbps
Supported Standards	SMPTE 259M, 292, 424M-2006
Re-clocked Data Rates	270 Mbps (SMPTE 259M), 1.485 Gbps (SMPTE 292), 2.97 Gbps (SMPTE 424M-2006)
Equalization	Automatic up to 100m of Belden 1694A at 3.0 Gbps, 200m at 1.485 Gbps and 350m at 270 Mbps
Return Loss	>10dB up to 2.97 Gbps

## Technical Specifications

### 3380 Transmitter Specifications (cont.)

#### Optical Output:

SMPTE 297-2006 Labeling	L-PC-ABCD-1310
Connector	LC receptacle, PC polish or ST
Wavelength	1310nm (nominal)
Emitter Type	FP Laser
Output Power ( <i>nominal</i> )	-3.5 dBm at 270 Mbps; -3.5 dBm at 1.485 Gbps; -3.5 dBm at 2.97 Gbps
Re-clocking	At 270 Mbps, 1.485 Gbps & 2.97 Gbps

#### Audio Specifications

Number of Audio Channels	4; Input: balanced or unbalanced Output: balanced, unbalanced loads supported with a 6 dB loss
Embedding (3380)	Selectable by group & pair; SMPTE compliant
SDI Pre-Embedded Audio	All channels supported for pass-through Pairs may be passed or embedded and are selectable on pair by pair basis
De-Embedding (3381)	Selectable by group and channel Channels may be muted or outputted on a channel by channel basis
Frequency Response	20 Hz - 20 kHz, +0/-0.5 dB
Bits-per-Sample/Sampling Rate	24 bits; 48 kHz
Maximum Audio Level	+24 dBu
SNR (A-Weighted)	105 dB
THD+N	0.002%, 20 Hz - 20 kHz
Channel Phase Differential	$\pm 0.05^\circ$
Crosstalk	Min. 100 dB (1 kHz)
Input Impedance	600 Ohms terminated; >24 k Ohms unterminated

## Technical Specifications

### Audio Specification (cont)

Output Impedance	50 Ohms
Switches	TX: Dip switches to select input termination TX/RX: Select one of four groups TX: Embed/Pass on a per-pair basis RX: Output/Mute on a per-channel basis
Connector	DB-25F, TASCAM Configuration, Channels 1-4

### 3381 Receiver Specifications

#### Fiber Optic Input

SMPTE 297-2006 Labeling	PC-ABCD-1310-1550
Connector	LC receptacle, PC polish or ST
Wavelength	1100 - 1620 nm
Minimum Input Sensitivity	-17 dBm at 2.97 Gbps; -20 dBm at 1.485 Gbps -21 dBm at 270 Mbps;
Maximum Input Power	0 dBm

#### Serial Video BNC Output

Number of Outputs	1
Signal Level	800mV $\pm$ 10%
DC Offset	0V $\pm$ 0.5V
Rise/Fall Time	< 135 ps at 2.97 Gbps per SMPTE 424M-2006; < 270 ps at 1.485 Gbps per SMPTE 292; 0.4 ns to 1.5 ns at 270 Mbps per SMPTE 259M
Overshoot	< 10% of amplitude
Timing Jitter	< 0.2 UI at 270 Mbps; < 1.0 UI at 1.485 Gbps; < 2.0 UI at 2.97 Gbps with color bar signal
Alignment Jitter	< 0.2 UI at 270 Mbps; < 0.2 UI at 1.485 Gbps; < 0.3 UI at 2.97 Gbps with color bar signal
Re-clocking	At 270 Mbps, 1.485 Gbps & 2.97 Gbps

## Optical Loss Budget & Maximum Usable Distance

Fiber Type	Loss(dB)	Data Rate	Distance
Single Mode	0-14	2.97 Gbps	30 km
	0-17	1.485 Gbps	48 km
	0-20	270 Mbps	50 km
Multimode ( 62.5u )	0-14	2.97 Gbps	.8 km
	0-17	1.485 Gbps	1 km
	0-20	270 Mbps	2.5 km
Multimode ( 50u )	0-14	2.97 Gbps	1 km
	0-17	1.485 Gbps	1.3 km
	0-20	270 Mbps	3 km

\*Distance specifications are approximate, based upon connecting a 3380 Transmitter to a 3380 Receiver, and are not guaranteed. Artel cannot estimate or guarantee operating loss budgets when the 3380 Series is used with other, non-FiberLink devices. Operating loss budget must not be exceeded.

## Alarm Switch Settings & Options

The Rack Card version of this product has an additional red indicator LED that illuminates when an alarm condition exists. The rack card unit also provides an output to drive a model 6020A Alarm Sensing Module which provides an audible tone and activates a set of contacts for external signaling purposes.

Alarm Switch as it appears on the card

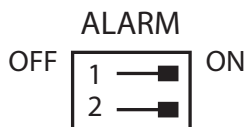

**Always leave Switch 1 in the ON position!**

## Alarm Switch Settings for the Transmitter Card

Switch Position	Alarm Indication	On	Off
1	Loss of Input Video	Enabled	Disabled
2	Not Used		

## Alarm Switch Settings for the Receiver Card

Switch Position	Alarm Indication	On	Off
1	Not Used - Always leave in the ON position		
2	Loss of Optical Signal	Enabled	Disabled

## Installation Instructions

The FiberLink 3380 Series of fiber optic transmission systems are ready for immediate use and do not require any special tools or equipment. However, an Optical Power Meter, such as the FiberLink 6615, can be useful in determining optical loss budgets during your systems design and maintenance.

### The following instructions describe the typical installation procedure:

- 1) Connect the video source to the video input BNC connector on the transmitter unit.
- 2) (Optional) Connect up to four analog audio sources to the audio input TASCAM DB-25 on the transmitter unit. XLR breakout cables are available for purchase.
- 3) Connect the video output cable to the video output BNC connectors on the receiver unit.
- 4) (Optional) Connect audio output cables to the TASCAM DB-25 on the receiver unit.
- 6) Connect the fiber optic cable to the transmitter and receiver units.
- 7) Connect the Universal Power Supply to the transmitter and receiver units.  
For box versions using DC power, please refer to figure 1.
- 8) Configure your audio preferences as described in the Audio Configuration section of this manual.
- 9) When power is applied, the green POWER LED should illuminate, indicating the presence of operating power. The 3G/HD/SD RATE LED and the audio LEDs will give an indication as described in the Indicator LED's and Alarm Circuitry section of this manual.
- 10) The system should now be operational.

*Note: The Rack Card version has an additional red LED for indicating the presence of an alarm condition (loss of signal). Refer to Indicator LED's and Alarm Circuitry sections of this manual.*

**Figure 1:**  
**Power Connector**  
**DC Input Polarity**

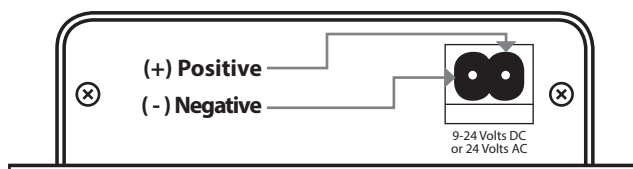

The transmitting element in the FiberLink 3380 transmitter unit contains a solid state Laser Diode located in the optical connector. This device emits invisible infrared electromagnetic radiation which can be harmful to human eyes. The radiation from this optical connector, if viewed at close range with no fiber optic cable connected to the optical connector, may be sufficient intensity to cause instantaneous damage to the retina of the eye. Direct viewing of this radiation should be avoided at all times!

**DANGER!**



## Audio Introduction:

The FiberLink 3380 & 3381 are designed to insert (3380) or extract (3381) one of the four groups of audio signals in an SDI signal. Each of the four audio groups contain two channel pairs. Each channel pair contains two audio signals. Therefore, a total of four analog audio signals can be encoded into the SDI signal by the 3380 transmitter or decoded from the SDI signal by the 3381 receiver.

The 3380 takes an SDI signal (BNC) and up to 4 balanced or unbalanced analog audio signals (DB-25 TASCAM) as inputs. There are 2 four position switches on the 3380. One to select the audio group (1-4) that the 3380 will embed into and to determine if it will embed the analog audio input signals or pass any audio signals previously embedded in the incoming SDI stream. This is done on a channel pair basis. The other four position switch selects the input impedance of each of the analog audio inputs. They can be set to 600 ohms or Hi-Z.

The 3381 Receiver has two four position switches, one to select the audio group (1-4) that will be de-embedded from the SDI signal and a second switch allows for the muting of the individual analog audio outputs.

The 3381 takes a SMPTE 297-2006 compliant fiber optic input transmitted from a 3380 transmitter, a 3360 transmitter, a 3350 transmitter, FiberLink Matrix or other SMPTE 297-2006 compliant optical device. This makes the 3380 Series very flexible in that you can cross convert analog to digital (3380 to 3361) or digital to analog (3360 to 3381).

Please see the following pages for detailed operational instructions, audio configuration settings and LED descriptions.

**Note: Audio embedding can only take place when a valid 3G/HD/SD-SDI video signal is present. The unit cannot be used as an audio only transmission system.**

## Balanced & Unbalanced Audio:

The FiberLink 3380 & 3381 have 25-pin DB-25F connector wired in a standard TASCAM configuration for audio input/output. The units are designed for balanced or unbalanced audio input and balanced or unbalanced audio output signals. When using an unbalanced output, the signal level will be 6 dBu below the input. To get the full level, you will need to utilize an external transformer or amplifier.

Balanced input/output connections are:

Hot(+), Cold (-), and Ground for each of the four channels.

Unbalanced signal connections should use: Hot(+) and Ground.

**The Cold(-) input should be left open. The Cold(-) output should not have a connection. Do not ground this output.**

## Pin-out for TASCAM DB-25F 8 Channel Balanced Connector

These channels are not supported by the 3380/3381 Series

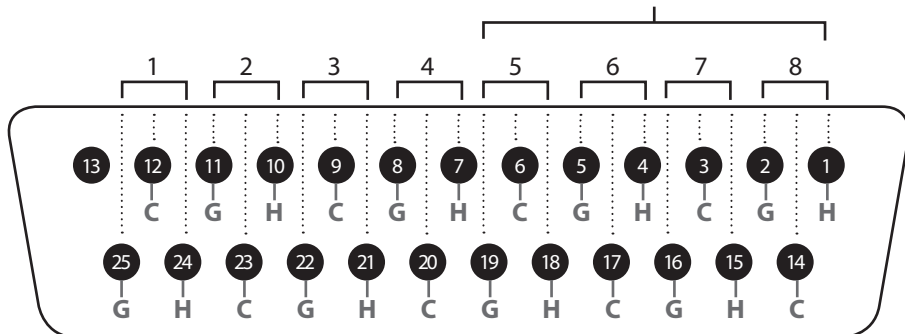

### Transmitter Box



### Receiver Box

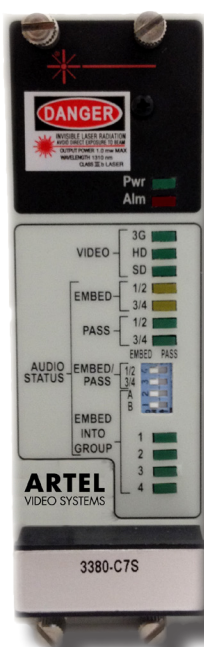
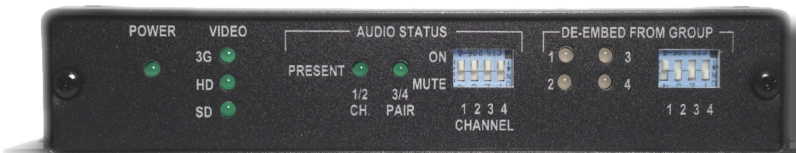

Transmitter Card

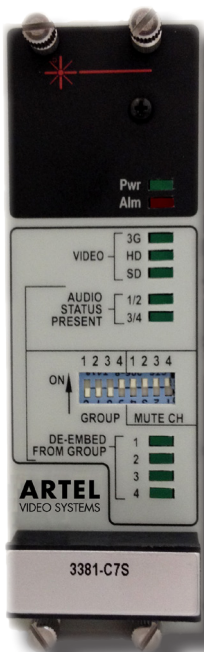

Receiver Card

### 3380 Transmitter Audio Configuration

#### Audio Status

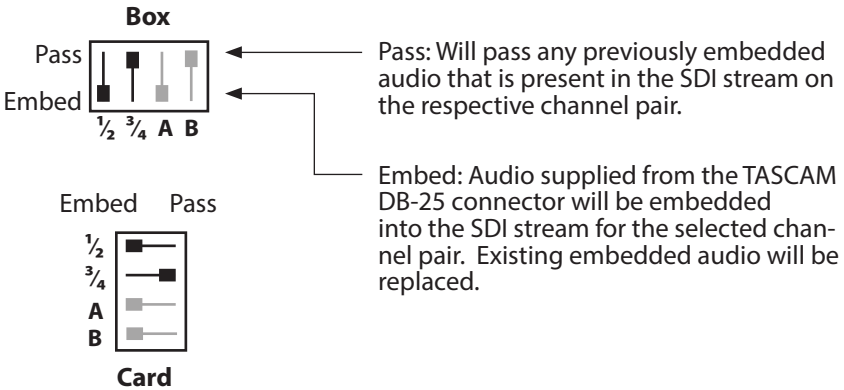

#### Embed Into Group

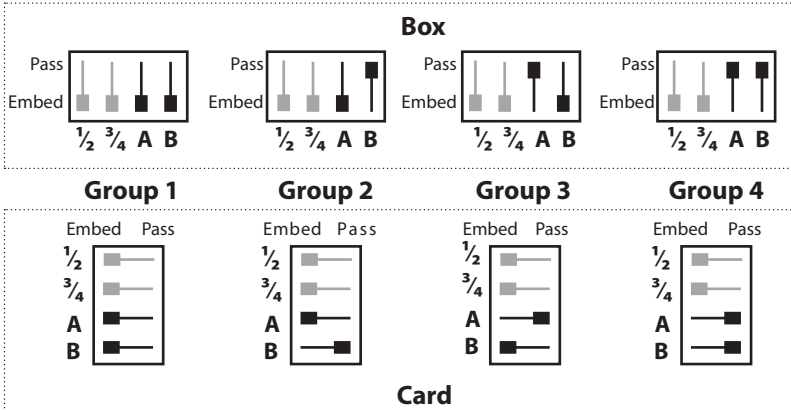

#### Termination by Channel

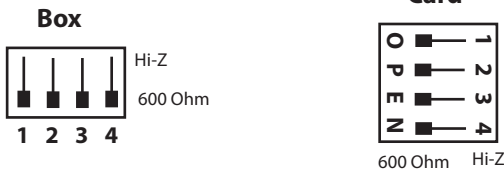

**NOTE:** Located on PCB

## 3381 Receiver Audio Configuration

### Audio Status

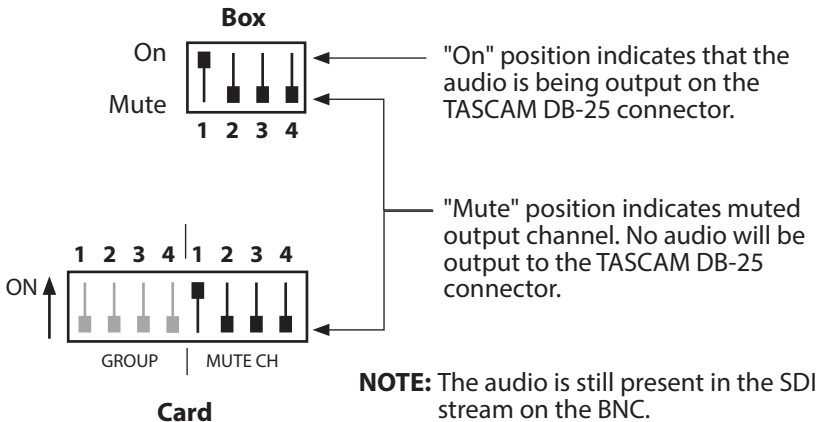

### De-Embed From Group

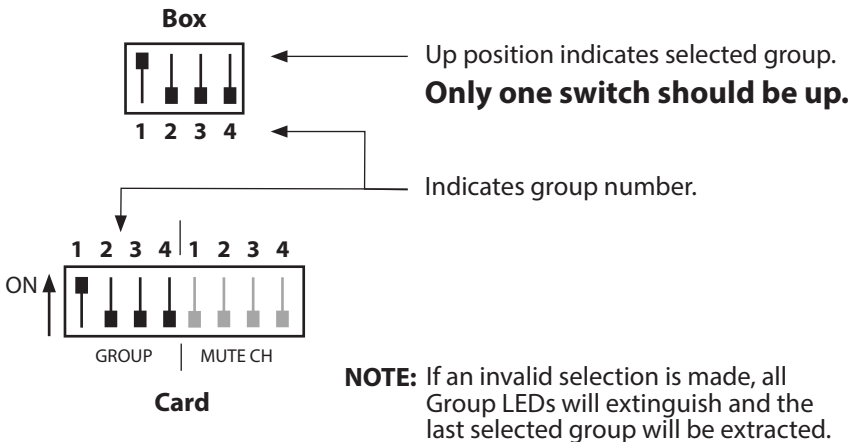

## Indicator LEDs

The FiberLink 3380 Series has several indicator LEDs that are used to monitor the state of the unit. Card versions have an additional Alarm LED.

Transmitter LEDs		
LED	Status	Definition
Power	On	Indicates that correct power has been applied.
Video		
3G Rate	Off	Indicates no 3G-SDI data rate lock
	On	Indicates 3G-SDI data rate lock at 2.97 Gbps or 2.97/1.001 Gbps
HD Rate	Off	Indicates no HD-SDI data rate lock
	On	Indicates HD-SDI data rate lock at 1.485 Gbps or 1.485/1.001 Gbps
SD Rate	Off	Indicates no SD-SDI data rate lock
	On	Indicates SD-SDI data rate lock at 270 Mbps
Audio Status		
Pass	Off	Indicates no audio present in the video stream
	On	Indicates audio present in the video stream and selected as the audio to pass
	Dim	Indicates audio present in the video stream but not selected as the audio to pass.
Embed	Off	Indicates no audio present on the analog input
	On	Indicates audio present on the DB-25 input and selected as the audio to embed
	Dim	Indicates audio present on the analog input but not selected as the audio to embed
Embed Into Group		
Group (1-4)	Off	Audio group is not used
	On	Indicates the audio group in the SDI signal that will be processed
Card Version		
Alarm	On	Loss of input video (card version only)

*Note: The 3G, HD and SD LEDs indicators are off when a non-standard signal is applied.*

## Receiver LEDs

LED	Status	Definition
Power	On	Indicates that correct power has been applied.

### Video

3G Rate	Off	Indicates no 3G-SDI data rate lock
	On	Indicates 3G-SDI data rate lock at 2.97 Gbps or 2.97/1.001 Gbps
HD Rate	Off	Indicates no HD-SDI data rate lock
	On	Indicates HD-SDI data rate lock at 1.485 Gbps or 1.485/1.001 Gbps
SD Rate	Off	Indicates no SD-SDI data rate lock
	On	Indicates SD-SDI data rate lock at 270 Mbps

### Audio Status

1/2 3/4	Off	Indicates no audio status present in the video stream
	On	Indicates audio status present in the video stream and being de-embedded and output on the respective audio output. Note: Audio status is always present when extracting group 3380 is inserting.

### De-Embed From Group

Group (1-4)	Off	Audio group is not used
	On	Indicates the audio group selected for extraction from the SDI stream. If all LEDs are off selection is illegal and last selected audio group will be extracted.

### Card Version

Alarm	On	Loss of input video (card version only)
-------	----	---

*Note: The 3G, HD and SD LEDs indicators are off when a non-standard signal is applied.*

## Operating Pointers

Remember to check attenuation of the fiber optic cable. The system will only operate properly if these specifications fall within the range of the system's loss budget.

Note: If no signal is applied to the 3380 Transmitter, no optical power will be present on the 3380 Transmitter's output.

## Troubleshooting

Multimode fiber optic cable contains an optical fiber with a light carrying "core" that is only .0025 inches (62.5 microns) in diameter. Single mode fiber optic cable has an even smaller "core," only .00032 to .0004 inches (8-10 microns). This is smaller than a human hair! Therefore, any minute particles of dirt or dust can easily block the fiber from accepting or radiating light. To prevent this from happening, always use the provided dust caps when ever optical connectors are exposed to air. It is also a good idea to gently clean the tip of an optical connector with a lint-free cloth moistened with alcohol whenever dust is suspected.

The status of the LEDs should provide the first clue as to the origin of any operational failure. If these are off, it usually means that the fiber is broken or has too much attenuation. Next, be certain that the input and output signal connections are correct.

An optical power meter, such as the FiberLink 6615, a visible light source, such as the FiberLink 6610, and a Three Wavelength Light Source, such as the FiberLink 6620, can greatly assist and expedite troubleshooting of fiber optic transmission systems and are recommended tools all installers should have available.

Finally, although multimode and single mode devices may look the same, they will not operate properly together. Using the wrong device or fiber can easily add more attenuation than specified, resulting in poor overall performance. It should be noted that some of our fiber optic products support both single mode and multimode fiber in the same unit.

If, after reviewing the above possibilities, the system is still not operating, please contact the Customer Service Department for further assistance. If you suspect your problem is caused by the optics or the fiber optic cable, and you have an optical power meter, please take the appropriate measurements prior to contacting support.



## Maintenance and Repairs

The FiberLink 3380 Series has been manufactured using the latest semiconductor devices and techniques that electronic technology has to offer. They have been designed for long, reliable and trouble-free service and are not normally field repairable.

Should difficulty be encountered, Artel Video Systems maintains a complete service facility to render accurate, timely and reliable service of all products.

The only maintenance that can be provided by the user is to ascertain that optical connectors are free of dust or dirt that could interfere with light transmission and that electrical connections are secure and accurate. Please see the Troubleshooting section of this manual for additional information.

An optical power meter, such as the FiberLink 6615, a visible light source, such as the FiberLink 6610, and a Three Wavelength Light Source, such as the FiberLink 6620, can greatly assist and expedite troubleshooting of fiber optic transmission systems and are recommended tools all installers should have available.

All other questions or comments should be directed to our Customer Service Department. It should be noted that many "problems" can easily be solved by a simple telephone call.

If you suspect your problem is caused by the optics or the fiber optic cable, and you have an optical power meter, please take the appropriate measurements prior to contacting support.

---

### Certifications





### FiberLink 6656 Visible Light Source

The FiberLink 6656 is a light-weight, hand-held tool used to quickly troubleshoot faults in the continuity of both single-mode and multimode fibers. High-intensity visible laser allows for visible fault location of breaks and micro-bends in both single-mode and multimode fibers



### FiberLink 6650 Optical Power Meter

The FiberLink 6650 Optical Power Meter is a high accuracy, high resolution, microprocessor controlled optical power meter. 65 dB dynamic range; calibrated to measure 850, 1300, 1310 and 1550nm. Works with multimode and single mode fiber. Graphical LCD display with intuitive user interface with simple 2-key operation.



### FiberLink 6652/6654 Light Sources

The FiberLink Light Source offers a laser output at selectable wavelengths, allowing for convenient, on-site testing of fiber networks during construction and maintenance procedures.



### FiberLink 6658

The FiberLink Optical Length Meter measures the length of both single mode and multimode fiber with accuracy of  $\pm 2.5$  meters. Generates a pulsed signal for use with fiber identifiers. Easy-to-read bright red 7-segment LED display. Comes equipped with industry preferred ST connectors.



## Proven Products, Unrivalled Service, and Great Support



- High performance plug and play products
- Stand alone and card cage versions available
- Solutions for most video, audio, and data formats
- Multimode and single mode versions
- Designed and manufactured in the USA
- Training and installation support available
- 24x7x365 technical support available



Artel Video Systems Corp.  
5B Lyberty Way,  
Westford, MA 01886 USA  
T: 978-263-5775  
F: 978-263-9755  
sales@artel.com  
customercare@artel.com  
www.artel.com

All specifications subject to  
change without notice. ©2016  
Updated 02/16/2016  
CS200-129453-00\_H