



# Encore™ MS-702

Two-Channel Main Station Instruction Manual



# Document Reference

Encore MS-702 Two-Channel Main Station Instruction Manual

Part Number: 810342Z Rev. 4

## Legal Disclaimers

Copyright © 2013 HME Clear-Com Ltd.

All rights reserved.

Clear-Com, the Clear-Com logo and Encore are registered trademarks or trademarks of HM Electronics, Inc.

The software described in this document is furnished under a license agreement and may be used only in accordance with the terms of the agreement.

The product described in this document is distributed under licenses restricting its use, copying, distribution, and decompilation/reverse engineering. No part of this document may be reproduced in any form by any means without prior written authorization of Clear-Com, an HME Company.

Clear-Com Offices are located in California, USA; Cambridge, UK; Montreal, Canada; and Beijing, China. Specific addresses and contact information can be found on Clear-Com's corporate website:  
[www.clearcom.com](http://www.clearcom.com)

### Clear-Com Contacts

Americas and Asia-Pacific Headquarters  
California, United States  
Tel: +1.510.337.6600  
Email: [CustomerServicesUS@Clearcom.com](mailto:CustomerServicesUS@Clearcom.com)

Europe, Middle East, and Africa Headquarters  
Cambridge, United Kingdom  
Tel: +44 1223 815000  
Email: [SalesSupportEMEA@Clearcom.com](mailto:SalesSupportEMEA@Clearcom.com)

Canada Office  
Quebec, Canada  
Tel: +1 (450) 653-9669

China Office  
Beijing Representative Office  
Beijing, P.R.China  
Tel: (008610)-8528-8748

# CONTENTS

## IMPORTANT SAFETY INSTRUCTIONS

OPERATION .....	1-1
Introduction .....	1-1
Description .....	1-1
Operation .....	1-2
Front Panel .....	1-2
Rear Panel .....	1-7
Re-Setting Program Interrupt Options .....	1-10
INSTALLATION .....	2-1
MAINTENANCE .....	3-1
Introduction .....	3-1
MS-702 Block Diagram .....	3-1
Troubleshooting Tips .....	3-2
Parts List .....	3-4
SPECIFICATIONS .....	4-1
LIMITED WARRANTY .....	5-1
Warranty Period .....	5-1
Technical Support .....	5-1
Warranty Repairs and Returns .....	5-2
Non-Warranty Repairs and Returns .....	5-2
Extended Warranty .....	5-2
Service Contract .....	5-3
Liability .....	5-3



# IMPORTANT SAFETY INSTRUCTIONS

*Please read and follow these instructions before operating this product.*

1. Read these instructions.
2. Keep these instructions.
3. Heed all warnings.
4. Follow all instructions.
5. Do not use this apparatus near water.
6. Clean only with dry cloth.
7. Do not block any ventilation openings. Install in accordance with the manufacturer's instructions.
8. Do not install near any heat sources such as a radiators, heat registers, stoves, or other apparatus (including amplifiers) that produces heat.
9. Do not defeat the safety purpose of the polarized or grounding-type plug. A polarized plug has two blades, with one blade wider than the other. A grounding-type plug has two blades and a third grounding prong. The wide blade or the third prong are provided for your safety. If the provided plug does not fit into your outlet, consult an electrician for replacement of the obsolete outlet.
10. Protect the power cord from being walked on or pinched particularly at plugs, convenience receptacles, and the point where they exit from the apparatus.
11. Only use attachments/accessories specified by the manufacturer.
12. Use only with the cart, stand, tripod, bracket, or table specified by the manufacturer, or sold with the apparatus. When a cart is used, use caution when moving the cart/apparatus combination to avoid injury from tip-over.
13. Unplug this apparatus during lightning storms or when unused for long periods of time.
14. Refer all servicing to qualified service personnel. Servicing is required when the apparatus has been damaged in any way, such as power-supply cord or plug is damaged, liquid has been spilled or objects have fallen into the apparatus, the apparatus has been exposed to rain or moisture, does not operate normally, or has been dropped.
15. **WARNING:** To reduce the risk of fire or electric shock, do not expose this product to rain or moisture.

**Please familiarize yourself with the safety symbols in Figure 1. When you see these symbols on this product, they warn you of the potential danger of electric shock if the unit is used improperly. They also refer you to important operating and maintenance instructions in the manual.**



This symbol alerts you to the presence of uninsulated dangerous voltage within the product's enclosure that might be of sufficient magnitude to constitute a risk of electric shock. Do not open the product's case.



This symbol informs you that important operating and maintenance instructions are included in the literature accompanying this product.

*Figure 1: Safety Symbols*

## **EMC AND SAFETY**

**The MS-702 meets all relevant CE, FCC, UL, and CSA specifications set out below:**

**EN55103-1 Electromagnetic compatibility. Product family standard for audio, video, audio-visual, and entertainment lighting control apparatus for professional use. Part 1: Emissions.**

**EN55103-2 Electromagnetic compatibility. Product family standard for audio, video, audio-visual, and entertainment lighting control apparatus for professional use. Part 2: Immunity.**

**UL 60065-7, CAN/CSA-C22.2 No.60065-3, IEC 60065-7 Safety requirements.**

**And thereby compliance with the requirement of Electromagnetic Compatibility Directive 2004/108/EC and Low Voltage Directive 2006/95/EC**

**This device complies with Part 15 of the FCC Rules. Operation is subject to the following two conditions: (1) this device may not cause harmful interference, and (2) this device must accept any interference received, including interference that may cause undesired operation.**

# 1

# OPERATION

*The MS-702 two-channel main station is a powerful, yet user-friendly unit that can serve as the heart of a Clear-Com system.*

## INTRODUCTION

Congratulations on choosing this Clear-Com product. Clear-Com was established in 1968 and remains the market leader in providing intercoms for entertainment, broadcast and industrial applications. The ruggedness and high build-quality of Clear-Com products defines the industry standard. In fact, many of our original beltacks and main stations are still in daily use around the world.

The MS-702 two-channel main station is a powerful, yet user-friendly unit that can serve as the heart of a Clear-Com system. We recommend that you read through this manual completely to better understand the functions of the MS-702. If you encounter a situation or have a question that this manual does not address, contact your dealer or call Clear-Com directly at the factory. Our applications support and service people are standing by to assist you. (Refer to Chapter 5: “Warranty” for contact information.) Thank you for selecting Clear-Com for your communications needs.

## DESCRIPTION

The Clear-Com MS-702 is a two-channel, one-rack space main station ideal for ENG and EFP trucks, production studio consoles, theatre, live performances, and small TV facilities. It features excellent speech intelligibility in all noise levels and can be tailored to your needs through its programmable options.

Selectable two-channel talking and/or listening allows the operator to communicate on either of the intercom channels separately or on both at once. The illuminated dual-action talk buttons provide electronic *momentary* or *latching* capability. Monitoring can be done through the headset, the integral speaker, or both at once. The MS-702 offers both visual and audible call signaling to attract the attention of operators who have removed their headsets or turned off their speakers. The *remote mic kill* (RMK) feature provides the ability to turn off all open mics on remote beltacks.

The MS-702 can control a paging speaker for studio announcements. A front panel button activates both this function and an associated relay. A balanced program input allows monitoring of external audio using the headset or speaker.

This main station accepts dynamic headsets. Individual sidetone controls for each intercom channel allow the operator to vary the level of his/her own voice as heard in the headset and speaker. It also accepts Clear-Com gooseneck panel microphones.

The integral speaker can be turned on or off by a convenient front panel switch. An automatic speaker dipping circuit will lower the level of the

speaker when the *announce* button, *talk* buttons or *program* interrupt are activated. This feature helps minimize feedback.

The MS-702 also incorporates a dual-channel program interrupt system (IFB). When activated, one or more stations can interrupt the program audio to either another intercom station or a talent wearing Clear-Com's wired or wireless talent receivers. Clear-Com's stand-alone IFB system can also be connected to this station.

The MS-702 provides 30-volt DC power to operate Clear-Com beltpacks and remote stations. This power is distributed between the two channels, and will support up to 60 headset stations or 20 speaker stations. Clear-Com's fail-safe design automatically shuts down the power to a channel when a short circuit or electronic overload is sensed on that channel. The other channel will continue to operate normally. Once the fault condition is removed, the MS-702's fail-safe circuit will restore power, even under full load conditions. LED indicators signal a short or overload on either channel.

The DC power output details are:

- 1.2A continuous output
- 2A peak output (not exceeding the 1.2A rating for more than 2 seconds per 30 second period)
- 1.75A max on any channel, with electronic current limiter (not exceeding the 1.2A rating for more than 2 seconds per 30 second period)

The MS-702 will operate from any AC line voltage between 90 and 240 volts AC at 50 or 60 Hz. The MS-702 installs in a standard 19-inch (48.26 cm) equipment rack, using only one rack space. The steel chassis and extra-thick front panel with integral rack ears maintains legendary Clear-Com ruggedness. Three 3-pin XLR connectors are provided for connection to each intercom channel.

The MS-702 is compatible with all Clear-Com party-line intercoms.

## OPERATION

Normal operation of the MS-702 main station requires access only to the front panel controls. The controls located elsewhere on the unit are intended to be set-and-forget in nature. For intercom operation, set the listen-level controls for each channel to the desired level and press the *talk* buttons when talking. If a headset is used, set the *sidetone* control for each channel for the desired amount of sidetone in the earphone. If using the panel mic and speaker, set the sidetone controls for minimum feed-through to the speaker to prevent feedback.

## FRONT PANEL

The controls, indicators, and connectors found on the MS-702 front panel are shown in the following figure and are described the text that follows. The numbers in the left column refer to Figure 1.



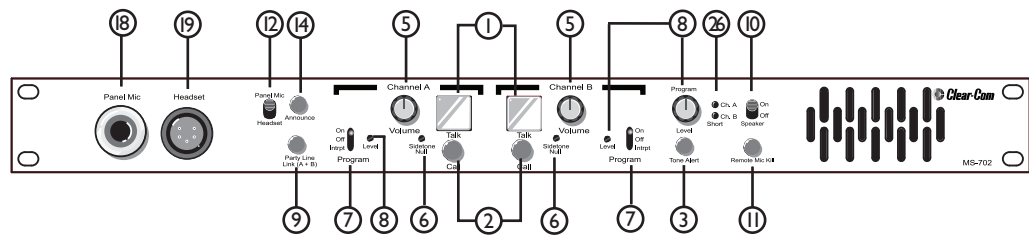

Figure 1: Front Panel

1. **Talk Buttons:** Each channel has an illuminated *talk* button for activating the microphone feed to that channel. Each talk button has a dual action (*momentary* or *latching* feature) depending on how the button is pressed. If desired, the latching function for each channel can be defeated using the option switches on the rear panel. The following describes the various functions of these multi-purpose buttons:
  - **MOMENTARY:** Press and hold the *talk* button while you are speaking. Release it when you are finished.
  - **LATCHING:** Press the *talk* button quickly to latch the talk function. Press the button again to turn off the talk function.
  - **TALK INDICATION:** The *talk* button will illuminate yellow whenever the talk function is activated. The *talk* button illuminates blue whenever the station is receiving power, but the talk function is off.
  - **CALL INDICATION:** The *call* button will flash red when a *call* signal is received on that channel.
  - **CALL ON TALK:** Each channel can optionally be set to send a *call* signal whenever you press the *talk* button. This function activates program interrupts or any other call-activated function available on other stations. Option switches on the rear panel enable this function.
  - **SPEAKER MUTE:** If the front panel speaker is turned on, pressing either *talk* button will reduce the speaker output level to avoid feedback.

The talk buttons can be labeled to indicate their function. To label the talk buttons, use the following procedure:

1. Pull the *talk* button straight off.
  2. Insert a small flat blade screwdriver into the slot between the cap and the body of the button and gently twist. This will remove the cap.
  3. Remove the square white diffuser from the cap.
  4. Insert a 1/2 in. (1.27 cm) x 1/2 in. (1.27 cm) square of thin paper with the needed description into the cap. Follow it up with the square white diffuser and press the cap onto the body of the button. Press the button back into the front panel.
2. **Call Buttons:** Each channel has its own *call* button. Pressing a call button will send a call signal on that channel. All the call lights on that channel will flash. Call signals can also be sent while talking if required. The *call*

button will flash while the call button is pressed, indicating the presence of a call signal on the line.

3. **Tone Alert:** An audible tone alert can be enabled to sound when a *call* signal is received on either channel. This can be useful when the operator's attention has been drawn away from the MS-702 indicator panel. Press the *tone alert* button to alternately enable or disable the audible tone alert. The button illuminates blue when the audible tone alert is enabled. When enabled, the tone alert will sound when a call button on a beltpack or station is pressed. The tone alert will not sound if a call signal is originated at the MS-702 station. The level can be adjusted by the control on the rear panel (See number 4 on the rear panel diagram later in this chapter).
5. **Listen Level Controls:** Each channel has a separate *listen level* control. Turn these controls to set the listen level you need on each channel. Turn the control completely counterclockwise to silence a channel.
6. **Sidetone Controls:** Each channel has a *sidetone null* control. Sidetone is the level of your own voice that you hear while talking on the intercom. Setting a comfortable level of sidetone will ensure that the intercom line sounds alive and also helps you modulate your voice relative to other voices on the line.

Typically, different *sidetone null* settings are needed depending upon whether you are using the gooseneck panel microphone along with the speaker. Use one of the following procedures to correctly set the sidetone level controls.

**Sidetone Adjustment Procedure for Gooseneck Microphone with Speaker turned on:**

1. Turn off the *party-line link (A+B)* switch.
2. Turn the level control for channel B all the way down. Set the *level* control for channel A to a comfortable level.
3. Press the channel A *talk* button and speak into the microphone while turning the *sidetone null* control for channel A slowly back and forth. There should be a point where your voice (and any accompanying acoustic feedback) disappears. This is the null point.
4. Repeat this procedure for channel B by turning the channel A *level* control down and adjusting the channel B controls.

**Sidetone Adjustment Procedure for Headset:**

1. Turn off the *party-line link (A+B)* switch.
2. Turn the level control for channel B all the way down. Set the *level* control for channel A to a comfortable level by having someone talk to you from another station.
3. Press the channel A *talk* button and speak into the microphone while turning the *sidetone null* control for channel A slowly back and forth until you hear your voice at a comfortable level in the headset.
4. Repeat this procedure for channel B by turning the channel A *level* control down and adjusting the channel B controls.

- 7. Program ON-OFF-INTRPT Switches:** The *program on-off-intrpt* switches are used to manually or automatically control program audio feed into the intercom lines. The settings are as follows:
- ON: The channel will receive program audio when the switch is set to *on*. The audio level for each channel can be adjusted with the program level trimpots.
  - OFF: The channel will not receive program audio when the switch is set to *off*.
  - INTRPT: Pressing the *talk* button will interrupt the program when this switch is set to *intrpt*.

**Note:** You can set this feature so the pressing the *call* button for a channel, rather than the *talk* button, interrupts the program audio. See the section “Resetting Program Interrupt Options” at the end of this chapter.

- 8. Program Level Controls:** Adjust the program-level controls to set the program audio level heard on the intercom. There are three program-level controls. The *program level* knob to the left of the speaker *on-off* switch adjusts the level of program heard in the headset or panel speaker.

The program levels heard on each intercom channel line can be individually adjusted, but this is intended to be a one-time setting made when the MS-702 is set up. This is done using the screwdriver level adjustment trimpots adjacent to the *program on-off-intrpt* switches on channels A and B. Set the *sidetone null* controls and the *program level* knob fully counter-clockwise when adjusting the individual channel program-level trimpots. After the program-level trimpots are properly adjusted, use the procedure listed in the **Sidetone Controls** section on this page to set the sidetone level.

**Note:** *Do not force the trimpots past their stop points. This will damage them.*

- 9. Party-line Link (A+B) Switch:** When pressed, the *party-line link (A+B)* button combines both intercom channels into one; for example, for rehearsals. The party-line link button illuminates amber when on, and all of the stations on the B channel will be moved onto the A intercom line. This will allow communication between everyone on both channels at once.

In this mode, the channel B controls and switches will be inactive. Since the wiring for the B channel has been now added to the A channel, the *sidetone null* control for channel A may require some readjustment.

- 10. Speaker ON/OFF Switch:** The *speaker on/off* switch turns the front panel speaker on or off. This switch does not affect whether the tone alert is heard through the speaker. The speaker volume will automatically dip whenever the panel or headset microphone is on.
- 11. Remote Mic Kill Switch:** The *remote mic kill (RMK)* switch will turn off the talk function of every beltpack on channels A and B. If the talk functions of a large number of beltpacks have inadvertently been left activated, incidental noise and talking can make it difficult or impossible to communicate on the party-line intercom. The RMK switch can be

pressed to quiet the line in this situation. Those needing to communicate can then set their talk functions to *on* as needed.

*Note:* The RMK switch can only function if the MS-702 main station is powering all of the stations in the system. The switch momentarily interrupts power to the other beltpacks and stations in the system. If there are other power supplies or main stations in the system, then the RMK switch cannot interrupt power and therefore cannot work.

- 12. **Mic Select Switch:** Set the *mic select* switch to select whether the panel microphone or the headset microphone is active.
- 13. **Panel Mic Gain:** This control is located on the inside of the MS-702 chassis. It may be used to increase or decrease the volume of the panel microphone. It has no effect on the sensitivity of the headset microphone.

To adjust the panel microphone gain, remove the top cover of the MS-702. Locate the R161 jumper, which is located on the leftmost side of the circuit board, toward the front of the MS-702 when facing it. Use a small screwdriver to turn the control clockwise to increase sensitivity or counterclockwise to decrease sensitivity.

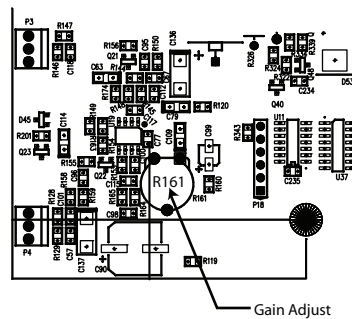

Figure 2: Gain Adjust Control R161

- 14. **Announce:** Press the *announce* button to make stage or PA system announcements. It directs the audio from the selected headset or panel microphone to the *annc out* rear panel connector and activates the announce relay. Simultaneously, if the program audio feed to the announce output is enabled, it is interrupted by the announcement. Program audio feed to the announce output is selected by setting jumper JP2 on the main board to the *on* position. Optionally, pressing the announce button can also disconnect the selected headset or panel microphone audio from the intercom line(s). This option is controlled by the *interrupt announce option* switch.
- 18. **Panel Mic Connector:** Clear-Com recommends the GM-9 and GM-18 plug-in panel microphones for use with the MS-702. The GM-9 is 9 in. (22.86 cm) long and the GM-18 is 18 in. (45.72 cm) long. The microphone is an electret type. The 1/4 in. (0.64 cm) phone jack on the microphone mates with the *panel mic* receptacle on the front panel of the MS-702.

To install a GM-9 or GM-18 microphone, use the following steps:

1. Check and unscrew the set screw in the mic mounting flange to make sure it is clear of the threads in the bushing.
2. Screw the microphone into the bushing hand tight.
3. Turn the set screw on top of the mic mounting flange clockwise to lock the microphone in place.

**19. Headset Connector:** The headset connector is located on the front panel. All Clear-Com headsets are recommended for use with the MS-702. The following is a description of the characteristics of a suitable headset:

Mic Type --- Dynamic; 150 to 250 ohms impedance; -55 dB output level

Headphone --- Dynamic; 50 to 2000 ohms impedance

The wiring of the headset is to be as follows:

Pin 1 --- Mic common

Pin 2 --- Mic hot

Pin 3 --- Headphone common

Pin 4 --- Headphone hot

The mic and headphone wiring in the headset cord must be individually shielded. **Do not connect pins #1 and #3 together.** Headset extension cords or headset “Y” cables are not recommended because they will increase crosstalk between channels.

26. **Short Lights:** There is one red light for channel A and one for channel B. These lights illuminate when the MS-702 senses a short or overload on the associated channel. When the fault is removed, the MS-702 will automatically reset and the light will go out.

## REAR PANEL

The controls and connectors found on the MS-702 rear panel are shown in the following figure and briefly described by the text that follows. The numbers in the left column refer to Figure 3.

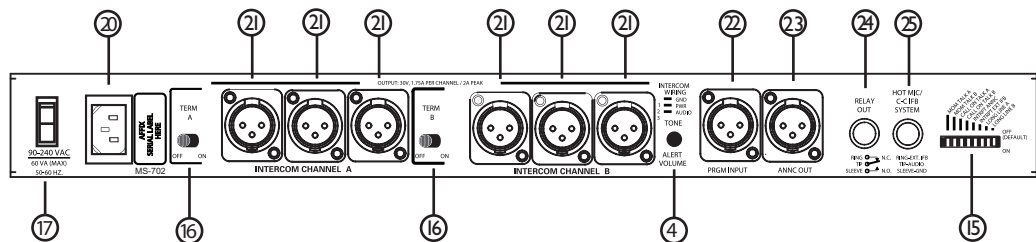

Figure 3: Rear Panel

4. **Tone Alert Volume Control:** This control adjusts the volume of the tone alert sound. This is normally adjusted when the system is set up and there should be no need to adjust it in normal operation.
15. **Option Switches:** Eight option switches are provided on the rear panel. They should be configured when the system is set up, but are not changed

in normal operation. The default position of the switches is in the *off* (up) position. The function of each switch is as follows:

1. MOM TALK A: Setting the *momentary talk A* switch to the *on* position will disable the latching function of the channel A *talk* button. In this mode, the *talk* button must always be held in continuously while the operator is talking on channel A.
  2. MOM TALK B: Setting the *momentary talk B* switch to the *on* position will disable the latching function of the channel B *talk* button. In this mode, the talk button must always be held in continuously while the operator is talking on channel B.
  3. CALL ON TALK A: If the *call on talk A* switch is set to the *on* position, a call signal will be placed on channel A whenever the *talk* function is activated. This can be used to activate any *call*-activated functions available on other stations.
  4. CALL ON TALK B: If the *call on talk B* switch is set to the *on* position, a call signal will be placed on channel B whenever the *talk* function is activated. This can be used to activate any *call*-activated functions available on other stations.
  5. INTRPT ANNC: If the *interrupt announce* switch is set to the *on* position, pressing the *announce* button will disconnect the microphone from the intercom line(s). This will allow announcements to be made without being heard over the intercom channels.
  6. INTRPT EXT IFB: When the *hot mic* output is connected to Clear-Com's IFB system and the *interrupt external IFB* switch is set to the *on* position, pressing a key on the IFB system will disconnect the selected headset or panel microphone from the intercom line(s). This allows the MS-702 microphone to be used to cue talent without affecting intercom line communication.
  7. LONG LINE A: If a long cable run on channel A is unavoidable and approaches 1,000 ft. (305 m) or more, set the *long line A option* switch to the *on* position. The ability to set a sidetone null on channel A depends upon properly setting this switch.
  8. LONG LINE B: If a long cable run on channel B is unavoidable and approaches 1,000 ft. (305 m) or more, set the *long line B option* switch to the *on* position. The ability to set a sidetone null on channel B depends upon properly setting this switch.
16. **Termination Switches:** These switches provide switchable terminations for channels A and B. In most systems, both terminations on the MS-702 should be in the *on* position (default setting). The fundamental concept of the Clear-Com party-line intercom is that all channels are terminated in one location, preferably at a main station or power supply. The termination switches on the MS-702 rear panel should be set to the *off* position **only** if the channel is terminated by another main station or power supply in the system. **If there are no other main stations, power supplies, or other terminations on the line, set the rear panel switches labeled *term A* and *term B* to the *on* position.**

*Note:* All intercom lines must be terminated only once, whether they are used or not. Never "double-terminate" a line.

17. **Power Switch:** The power switch can be used to turn AC power to the MS-702 on and off. When in the *on* position, the front-panel *talk* buttons illuminate blue.
20. **AC Power Connection:** An IEC type 320 connector is provided to interface to the appropriate AC power cord to be used. Voltages from 90 to 240 VAC at 50 or 60 Hz are acceptable. The MS-702 will automatically adjust for the power applied, so there are no manual switches to set power line voltage or frequency.
21. **Intercom Line Connection:** The MS-702 contains three 3-pin male XLR connectors for each intercom line. These connectors are wired in parallel. Any single-channel station or channel of a multi-channel station connected on a line plugged into channel A of the MS-702 will be “party lined” with all the other stations on that channel. In a multi-channel system, the goal is to assign specific people to the correct group (i.e. the other people they need to be in contact with the most). This is particularly important when the party-line users are on a single-channel beltpack or station, less so if they are on multi-channel stations. The pinout of the intercom connectors is as follows:
  - Pin 1 --- Ground (shield)
  - Pin 2 --- Power (+30 VDC)
  - Pin 3 --- Audio
22. **Program Input:** A 3-pin XLR female connector provides the main program input to the station. Program can be fed to the headphone or speaker as well as to either or both of the intercom channels. The level to the speaker or headphone is controlled by the *program level* control. The program *on-off-intprt* switches control whether each intercom channel receives program audio. The program audio levels on each intercom channel can be adjusted using the individual program-level trimpots. The *program* input accepts a balanced or unbalanced line-level audio signal from -20 dBv to +10 dBv. An option is to feed program audio to the *announce* output. This is selected by setting jumper *JP2* on the main board to the *on* position. When this option is selected, a 0 dBv signal on the program input will produce a 0dBv signal on the announce output.

The pinout of the *program input* connector is as follows:

  - Pin 1 --- Ground (shield)
  - Pin 2 --- + Signal
  - Pin 3 --- - Signal
23. **Announce Out:** A 3-pin XLR male connector is provided as a feed to a studio PA amplifier. Pressing the *announce* button on the front panel places the audio from the selected headset or panel microphone on the *annc out* rear-panel connector. Optionally, pressing the announce button can also disconnect the selected headset or panel microphone from the intercom line(s). This option is controlled by the *interrupt announce option* switch. Simultaneously, if the program audio feed to the announce output is enabled, it is interrupted by the announcement. Program audio feed to the announce output is selected by setting jumper *JP2* on the main board to the *on* position. The pinout of the *announce out* connector is as follows:

Pin 1 --- Ground (shield)

Pin 2 --- - Signal

Pin 3 --- + Signal

The audio output is balanced and transformer isolated. It has a 600 ohm impedance and a nominal output level of 0 dBV. A shielded twisted pair cable should be used in the cable wired to this connector.

24. **Relay Out:** A dry set of relay contacts is provided through a 1/4-in. (0.64 cm) jack to activate external switching as needed when the *announce* button is pressed. These contacts can be used to control an external device such as a PA amplifier to another room. The contacts are rated for 2.0 A at 24 VDC. The contacts are wired as follows:

Ring --- Normally closed contact

Tip --- Common contact

Sleeve --- Normally open contact

25. **Hot Mic Out / IFB System:** This connection is a 1/4-in. (0.64 cm) phone jack. It provides a 0 dBV output signal from the selected headset or panel microphone. This output is intended interface with the external line-in jack on Clear-Com's IFB System.

The jack is wired as follows:

Ring --- Ext. IFB control signal input

Tip --- Hot mic audio output

Sleeve --- Ground (shield)

27. **Headset Audio Limiter:** To protect the hearing of the user, the *headset audio limiter* restricts the maximum audio level heard in the headset. The MS-702 unit is shipped with the *headset audio limiter* on. You can turn this feature on or off by using a jumper located on the main circuit board.

**To turn the audio limiter on or off:**

1. Please observe anti-static procedures. Circuit cards can be damaged by static electricity. Please ground yourself and tools before touching any circuit cards.
2. Disconnect the unit from AC mains electricity.
3. Remove the cover of the RM-702.
4. Locate the three-pin jumper labeled "J3" on the center frontmost portion of the circuit card.
5. A jumper plug is located over pins 2 and 3. This is the *on* setting.
6. Do one the following to turn the audio headset limiter feature on or off:
  - To turn the feature on, place the jumper plug over pins 2 and 3.
  - To turn the feature off, place the jumper plug over pins 1 and 2.
7. Replace the cover of the RM-702.



8. Connect the unit to AC mains electricity.

## RE-SETTING PROGRAM INTERRUPT OPTIONS

When you set one of the front-panel *Program ON-OFF-INTRPT* switches to the INTRPT position, any *talk* signal activated on that channel interrupts the *program audio* during the talk signal.

You can change this option so that activating a *call* signal, rather than a *talk* signal, interrupts the program audio for the duration of the signal. You do this by re-setting an internal jumper on the station's internal circuit board.

### To re-set the program interrupt option:

1. Please observe anti-static procedures. Static electricity can damage a circuit card. Please ground yourself and tools before touching the circuit card.
2. Remove the cover of the MS-702 by removing the eight Phillips screws.
3. On the main circuit board, locate one of the following:
  - **For channel A:** The JP5 three-pin jumper, located in the center of the circuit board.
  - **For channel B:** The JP6 three-pin jumper, located in the center of the circuit board.
4. A jumper plug covers two of the three pins on each jumper. To change the program-interrupt option on your station, do one of the following:
  - **For channel A:** Move the jumper plug so that it covers pins 2 and 3. This causes call signal activation to interrupt the program audio
  - **For channel B:** Move the jumper plug so that it covers pins 2 and 3. This causes call signal activation to interrupt the program audio.

In the default position, the jumper plug covers pins 1 and 2, which causes *talk* signal activation, rather than *call* signal activation, to interrupt the program audio.

JP5, for channel A



JP6, for channel B

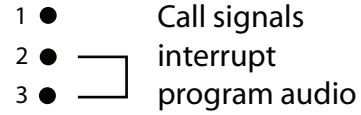

**FOR EITHER CHANNEL:**

To interrupt program audio during talk signals, place jumper plug over pins 1 and 2.

To interrupt program audio during call signals, place jumper plug over pins 2 and 3.

*Figure 4: Changing Program Interrupt Options*

# 2

## INSTALLATION

1. Unpack the unit and inspect for any damage that may have occurred in shipping.
2. Connect the proper AC mains cable.
3. Install the MS-702.

***Note: For additional information, refer to the Clear-Com System Installation Manual.***

4. Connect the AC to the mains circuit.

***Note: Information on the mains power requirement is given on the underside of the unit.***

5. Connect the intercom lines.
6. Set the two termination switches on the rear panel to *on*.
7. Set the *option* switches to the default (up) position.
8. Switch power *on*.

The blue *talk* button lights should be *on* and the two red short lights should be *off*.

9. Set listen levels and sidetones.

Refer to the listen level and sidetone setting topics in the *Operation* section of this manual.

10. The intercom system should now be operating properly.

Read the rest of this manual for further information.



# 3 MAINTENANCE

## INTRODUCTION

This chapter provides maintenance information, including a block diagram and troubleshooting tips.

**Caution:** These servicing instructions are for use by qualified personnel only. To reduce the risk of electrical shock, do not perform any servicing other than that contained in the operating instructions unless you are qualified to do so.

## MS-702 BLOCK DIAGRAM

The following is a block diagram of the MS-702:

MS-702

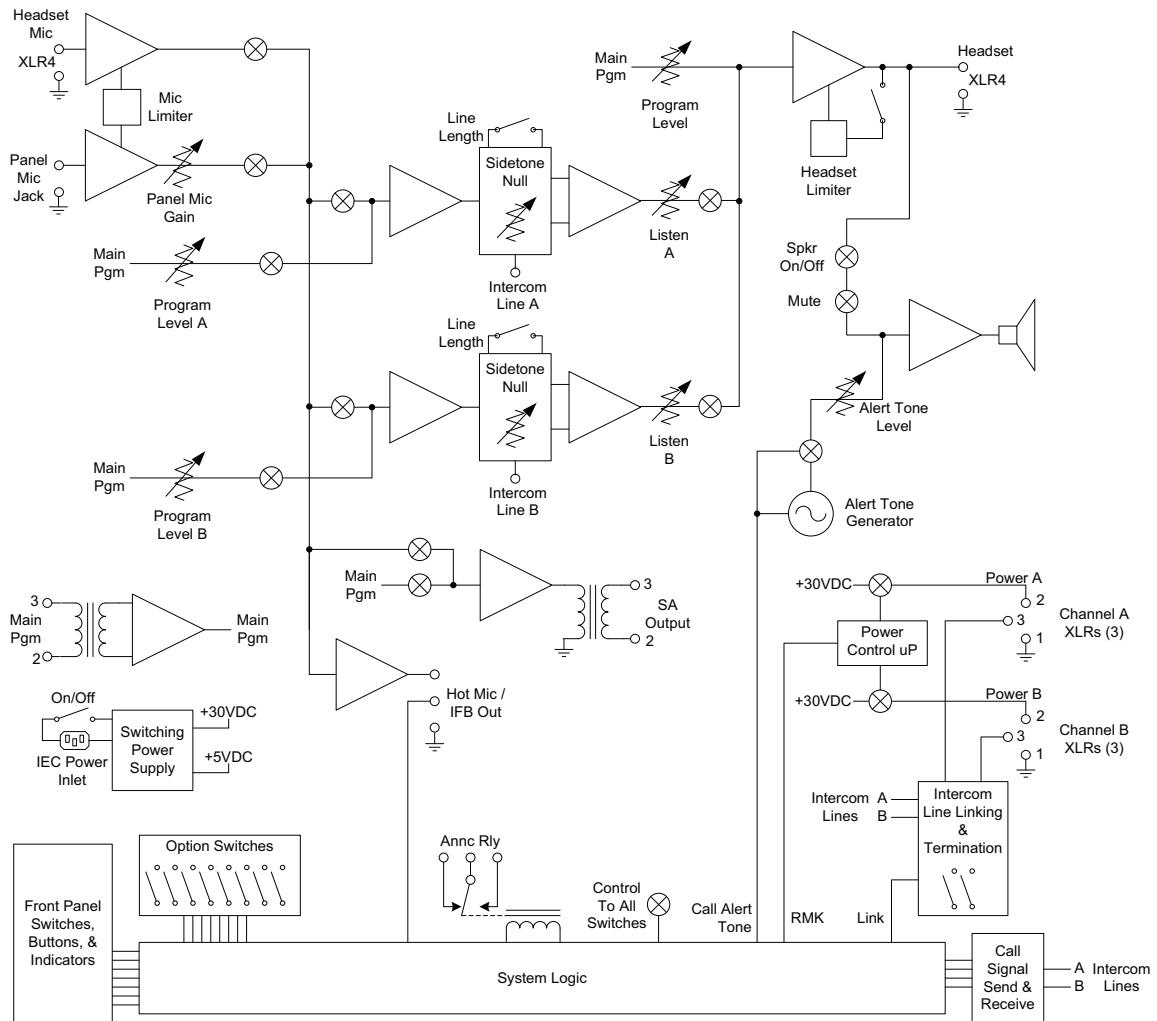

Figure 3-6: Block diagram of the MS-702

# TROUBLESHOOTING TIPS

SYMPTOM	CAUSE	SOLUTION
System does not operate. Blue talk <i>buttons</i> do not illuminate and <i>short</i> lights do not illuminate.	No AC power to the MS-702.	Make sure the power switch on the rear panel is turned <i>on</i> . Check the AC connection and cable. Plug into a dependable AC source.
	The MS-702 has an internal power supply failure.	Unit requires servicing.
System does not operate when power switch is turned on. Blue <i>talk</i> lights and red <i>short</i> lights wink.	Direct short on the intercom channel indicated by the red <i>short</i> light.	Remove the intercom line cables one at a time from that channel until the faulty line is located. Once the short is removed, the MS-702 will reset automatically and power will come back up. Check for shorts between pins #1 and #2 or improper cable wiring.
Red <i>short</i> light is illuminated.	Short or overload on that channel due to a shorted or miswired cable.	Remove the intercom line cables one at a time from the system until the faulty line is located. (The red <i>short</i> light will then turn off.) Check for shorts between pins #1 and #2 or improper cable wiring. Once the short is removed, the MS-702 will reset automatically and power will come back up.
	Defective remote station.	Check the remote station and replace if necessary.
Both red <i>short</i> lights are illuminated.	System is overloaded.	Remove the intercom line cables one at a time from the system to help determine where the excess current requirements lie. Re-evaluate the system current needs.
	Short in multipair cable.	Remove the intercom line cables one at a time from system until the faulty line is located. Check for shorts between pins #1 and #2 or improper cable wiring.
Problem: Hum or buzz in system.	Inductive pickup caused by close proximity of this main station or connected remote stations to power lines or transformers.	Relocate the offending unit.

SYMPTOM	CAUSE	SOLUTION
	10 Ohm chassis ground resistor is open.	<p>Check the DC resistance for 10 Ohms between the chassis and pin #1 of any intercom connector.</p> <p><b>If this condition occurs, it is because the system ground came into contact with something that was “HOT” with respect to the power supply earth ground. Carefully check the system ground and AC distribution in the area.</b></p> <p><i>Warning: This is a potentially dangerous situation. A shock hazard may exist between a remote station headset and ground.</i></p>
System feedback (Acoustical)	<i>Listen level</i> control at this station or a remote station is set too high.	Adjust.
	<i>Sidetone null</i> control at this station or a remote station is not adjusted correctly.	Adjust. Refer to the procedure in the front panel section of this manual.
	Channel unterminated.	Set the MS-702 termination switch for that channel to the <i>on</i> position.
	A headset extension cord was used.	Headset extension cords are not recommended.
Excessive crosstalk	High DC resistance in ground return.	Use heavier cable; add additional conductor(s) to ground return.
	<i>Multi-channel</i> cable pairs are not individually shielded.	Replace cable with individually shielded pairs.
	Headset cables are not wired properly or shielded properly.	Correct wiring. Use headsets with properly shielded wiring.
Program signal sounds distorted.	Overload of <i>program input</i> circuit.	Reduce <i>program input</i> level or reduce the gain of the program signal at the source, such as an audio mixer.
Call signals do not function.	Excessive DC loading of intercom line.	Remove any audio transformers or other equipment that may be connected across the intercom line. If equipment other than Clear-Com intercom equipment must be connected to the intercom line, please contact Clear-Com application or service personnel for advice.

SYMPTOM	CAUSE	SOLUTION
	Far too many terminations on the intercom line.	Check all main stations and power supplies to make sure each intercom channel is terminated at only one point.

*Table 3-1: Troubleshooting Tips*



# 4

## SPECIFICATIONS

dBv is an absolute measurement. 0 dBv is referenced to 0.775 V RMS.

### Headset Microphone Pre-Amp

Input Type: Dynamic  
Impedance: 1K $\Omega$   
Input Level: -55 dBV nominal; -10 dBV max.  
Frequency Response: 200 Hz to 15 kHz  
Gain from headset mic to intercom line: +41 dB

### Panel Microphone Pre-Amp

Input Type: Electret  
Input Level: -45 dBV nominal  
Frequency Response: 450 Hz to 12 kHz  
Gain from panel mic to intercom line: +31 dB

### Headphone/Speaker Amplifier

Load Impedance Range: 50 $\Omega$  - 2 K $\Omega$   
Output Level: At least +20 dBV across 600 $\Omega$   
Distortion: < 0.2% THD @ 1 KHz  
Frequency Response: 200 Hz - 18 KHz,  $\pm 2$  dB  
Gain from intercom line: +37 dB  
Power Output: 110 dB SPL

### Program Amplifier (Transformerless, balanced differential input)

Input Level: 0 dBV  
Input Impedance: > 100 K $\Omega$   
Frequency Response: 150 Hz - 18 KHz,  $\pm 2$  dB

### Termination Impedance

Impedance: 200 $\Omega$ , switchable

### Power Supply

Type: Switching, with overcurrent limiting and reset  
circuitry for each channel  
Output Voltage: 30 volts DC regulated  
Output Current: 1.2A Continuous  
2A Peak (Do not exceed the 1.2A rating for more than 2 seconds per 30 second period)  
1.75A max any channel, with electronic current limiter (Do not exceed the 1.2A rating for more than 2 seconds per 30 second period)

Short Circuit Reset Time: < 15 s  
Hum and Noise: < -80 dBv

## Station Capacity

Capacity:  
Maximum of 60 headset stations or 20 speaker stations, distributed over both channels

## Rear Panel Connectors

Intercom: (6) XLR-3M (3 per channel)  
Announce Out: (1) XLR-3M (audio)  
Announce Relay: (1) 1/4 in. (0.64 cm) phone jack (relay)  
Program: (1) XLR-3F  
Hot Mic / IFB Interface: (1) 1/4 in. (0.64 cm) phone jack  
AC Power: IEC 320 connector

## Rear Panel Controls

(2) Termination On-Off switches  
(8) Option switches  
(1) Power switch  
(1) Tone alert volume control

## Front Panel Connectors

Panel Mic: (1) 1/4 in. (0.64 cm) panel mounting jack  
Headset: (1) XLR-5F

## Front Panel Controls & Indicators

(1) Panel / headset mic switch  
(1) Announce button  
(1) Party line link button  
(2) Program ON-OFF-INTERRUPT switches  
(3) Program level controls  
(2) Listen controls  
(2) Sidetone null controls  
(2) Talk buttons  
(2) Call buttons  
(1) Tone alert button  
(1) RMK button  
(1) Speaker ON-OFF switch  
(2) Short LEDs

## Power Requirements

90 - 240 VAC, 50 - 60 Hz, 60 VA

## Environmental

32 - 122° F (0 - 50° C)

## Dimensions

19 in. W x 1.75 in. H x 6.5 in. D (483 mm x 44 mm x 165 mm)

**Weight**  
5.0 lbs. (2.75 kg)

### Notice About Specifications

While Clear-Com makes every attempt to maintain the accuracy of the information contained in its product manuals, that information is subject to change without notice. Performance specifications included in this manual are design-center specifications and are included for customer guidance and to facilitate system installation. Actual operating performance may vary.



# LIMITED WARRANTY

This document details the Clear-Com Standard Limited Warranty for all new products for sale within all regions with the exception of Military, Aerospace, and Government (MAG).

**EXCEPT AS SET FORTH HEREIN ("LIMITED WARRANTY"), CLEAR-COM MAKES NO OTHER WARRANTIES, EXPRESS, IMPLIED OR STATUTORY, INCLUDING WITHOUT LIMITATION ANY WARRANTIES OF MERCHANTABILITY, NONINFRINGEMENT OF THIRD PARTY RIGHTS, OR FITNESS FOR A PARTICULAR PURPOSE, ALL OF WHICH ARE EXPRESSLY DISCLAIMED.**

1. **Standard Limited Warranty.** Clear-Com warrants its products, including supplied accessories, against defects in material or workmanship for the time periods as set forth below provided it was purchased from an authorized Clear-Com dealer or distributor.

a) Pursuant to this Limited Warranty, Clear-Com will, at its option:

- i) repair the product using new or refurbished parts, or;
- ii) replace the product with a new or refurbished product.

b) Remedies: In the event of a defect, the rights detailed in 1 (a) are your exclusive remedies. For purposes of this Limited Warranty, "refurbished" means a product or part that has been returned to its original specifications.

c) Standard Warranty Period (by Product):

i) All Clear-Com brand systems and products, including belt packs, have a Limited Warranty of two years, with the exception of;

(1) Cables, accessories, components & consumable items have a Limited Warranty of 90 days.

(2) Any Clear-Com product that has been classified as obsolete at the time of sale has a Limited Warranty of 90 days from sales and will be replaced with the same product or a sales credit will be issued, at the sole discretion of Clear-Com.

(3) Headsets, handsets, microphones, and associated spare parts, as well as UHF wireless IFB products, have a Limited Warranty of one year.

(4) UHF WBS Analog wireless intercom systems have a Limited Warranty of three years.

- (5) All software products, including Concert (Client and Server), ECS, Production Maestro and Logic Maestro are warranted for one year and shall substantially conform to published specifications. The media on which the Software is furnished is warranted to be free of defects in material and workmanship (under normal use) for a period of one year.
  - (6) Any Clear-Com products that are listed within the last time buy period have the same Limited Warranty for their type 1.i 1 - 1.i.5 as above.
- d) Any Clear-Com product that is repaired or supplied as a replacement under the terms of this Limited Warranty shall inherit the remaining warranty period from the original product.
- e) Standard Warranty Period Start Date
- i) Dealer / Distributor Sales: In view of Dealer or Distributor stocking practices, the Standard Warranty Period for products sold through Dealers or Distributors will commence from the Clear-Com invoice date and will include an automatic extension of three months. Any valid warranty claim within the Standard Warranty Period as determined by the Clear-Com invoice date will be covered without further supporting evidence. All warranty claims after this date must be supported by the Customer's proof of purchase that demonstrates the product is still within the Standard Warranty Period (as detailed in Section 1.c.i above, plus the automatic three month extension) from their purchase date.
  - ii) Direct Sales: The Standard Warranty Period will commence from the date the product was shipped from Clear-Com to the Customer. The Standard Warranty Period start date for contracts that include commissioning will be the date of the Site Acceptance Test (SAT) or one month from conclusion of the commissioning project, whichever is earlier.
- f) Invalidation of Warranty
- i) This Limited Warranty shall be invalidated if the product's outer case has been opened and internal modifications have been made or damage has occurred, or upon the occurrence of other damage or failure not attributable to normal wear and tear. Authorized modifications with Clear-Com's express written permission will not invalidate the warranty.
- g) Software Updates
- i) Software Updates are released periodically to correct discovered program bugs. During the Warranty Period, software updates are available to Customers free of charge.

## h) Software Upgrades

- i) Software Upgrades include new Features and/or Functional Enhancements and are not included as part of the Standard Warranty but may be purchased at the published rates.
- ii) Note: In the absence of a Software Update containing a program correction and no available workaround to mitigate the problem, at the discretion of Service, Sales, Engineering, or Product Management, the Customer may be provided a Software Upgrade under warranty.

2. **Exclusions.** Services do not cover damage or failure caused by any occurrence beyond Clear-Com's reasonable control, including without limitation acts of God, fire, flooding, earthquake, lightning, failure of electric power or air conditioning, neglect, misuse, improper operation, war, government regulations, supply shortages, riots, sabotage, terrorism, unauthorized modifications or repair, strikes, labor disputes or any product failure that Clear-Com determines is not a result of failure in the Services provided by Clear-Com. Further Services excluded from this Agreement include: services required due to errors or omissions in Customer purchase orders; installation or maintenance of wiring, circuits, electrical conduits or devices external to the products; replacement or reconditioning of products which, in Clear-Com's opinion cannot be reliably maintained or properly serviced due to excessive wear or deterioration; Customer's failure to maintain the installation site in accordance with the environmental specifications of the products; or service on products removed from the location originally specified by Customer and/or reinstalled without the prior written approval of Clear-Com. Customer will pay Clear-Com's then current published charges to restore such Covered Products to a condition eligible for further service under this Agreement. Clear-Com shall be excused from and shall not be liable for any failure or delay in performance under this Agreement due to the foregoing or any causes beyond its reasonable control.

3. **Limitation of Liability.** IN NO EVENT WILL CLEAR-COM BE LIABLE UNDER THIS AGREEMENT FOR ANY INDIRECT, SPECIAL, INCIDENTAL OR CONSEQUENTIAL DAMAGES (INCLUDING WITHOUT LIMITATION LOST PROFITS), REGARDLESS OF THE FORM OF ACTION, EVEN IF ADVISED IN ADVANCE OF THE POSSIBILITY OF SUCH DAMAGES.

4. **Assignment.** Neither party may assign this Agreement or any portion thereof without the prior written consent of the other, except in the event of a merger, sale of all or substantially all of the assets or other corporate reorganization.

5. **Ownership of replaced parts or product.** All replaced parts or products become the property of Clear-Com.

6. **Entire Agreement.** This Agreement constitutes the entire agreement between the parties with respect to the subject matter hereof, and supersedes all prior or contemporaneous proposals, oral or written, and all other communications between them relating to the subject matter of this Agreement.

