

VERIS 2

VERsatile **I**nstallation **S**ystems



Exquisite Performance...Exceptional Value

Operation Manual



EC STATEMENT OF CONFORMITY

This document confirms that the range of products of Community Professional Loudspeakers bearing the CE label meet all of the requirements in the EMC directive 89/336/EEC laid down by the Member States Council for adjustment of legal requirements. Furthermore, the products comply with the rules and regulations referring to the electromagnetic compatibility of devices from 30-August-1995.

The Community Professional Loudspeaker products bearing the CE label comply with the following harmonized or national standards:

DIN EN 55013:08-1991

DIN EN 55020:05-1995

DIN EN 55082-1:03-1993

The authorized declaration and compatibility certification resides with the manufacturer and can be viewed upon request. The responsible manufacturer is the company:

Community Light & Sound
333 East 5th Street
Chester, PA 19013 USA
TEL: 1-610 876-3400
FAX: 1-610 874-0190

Chester, PA USA June 2012

WARRANTY INFORMATION

Community VERIS 2 loudspeakers and accessories are warranted in the USA to be free from defects in materials and workmanship for a period of five (5) years, as determined by one of the following two methods, whichever is longer:

1. Starting from the date of retail purchase, as noted on the sales receipt from an authorized Community dealer,
OR
2. Starting from the date of manufacture, determined by the serial number, if the sales receipt is not available.

TRANSFERABLE WARRANTY "(LIMITED)" VALID IN THE USA ONLY

For complete warranty information within the USA please refer to the Warranty Card enclosed with the product. Please call [610-876-3400](tel:610-876-3400) to locate your nearest Authorized Field Service Station. For Factory Service call [610-876-3400](tel:610-876-3400). You must obtain a Return Authorization (R/A) number prior to the return of your product for factory service.

WARRANTY INFORMATION AND SERVICE FOR COUNTRIES OTHER THAN THE USA

To obtain specific warranty information and available service locations for countries other than the United States of America, contact the authorized Community Distributor for your specific country or region.

Notice: Every effort has been made to insure that the information contained in this manual was complete and accurate at the time of printing. However, due to ongoing technical advances, changes or modifications may have occurred that are not covered in this manual.

TABLE OF CONTENTS

Warranty Information.....	2
Important Safety Information.....	4
Rigging And Electrical Safety.....	4
Precautions & Safety Considerations	5
Introduction	6
VERIS 2 Technologies	7
Unpacking and Inspection.....	8
VERIS 2 Specifications	9
Getting Acquainted	11
Physical Features of VERIS 2 Full-Range Models	11
Physical Features of VERIS 2 Subwoofers	12
General Description	13
DYNA-TECH™ Driver Protection System.....	13
COOL-COIL™ Technology	14
High-Pass Filters.....	15
Connecting the Amplifier to the Loudspeaker.....	16
PIN Designations.....	16
Using Power Taps.....	17
70.7V and 100V Systems	18
Wiring NL4 Type Connectors.....	18
Know Your Amplifier	19
Choosing Loudspeaker Wire.....	19
Conductors and Insulation.....	20
The Effect Of Wire Gauge On Damping Factor.....	21
Selecting Amplifiers.....	21
VERIS 2 Applications.....	22
Positioning Subwoofers.....	23
Polarity	25
Choosing Appropriate Loudspeaker Models and Appropriate Signal Processors.....	26
dSPEC226 – The Simple and Effective Answer.....	27
Commissioning the System	27
For More Information and Application Assistance.....	28
Rigging / Suspension and Safety	29
Important Notes on Rigging Loudspeakers	29
VERIS 2 Mounting Brackets and Accessories	30
Troubleshooting Guide	32
Servicing VERIS 2 Loudspeakers.....	32
Technical Drawings	33

IMPORTANT SAFETY INFORMATION

Always follow these safety precautions when using or installing VERIS loudspeakers and accessories:

- Read and keep these instructions
- Heed all warnings
- Follow all instructions, particularly those pertaining to rigging, mounting, hanging, and electrical connections
- Only use accessories that are specified and approved by Community

The terms **IMPORTANT**, **WARNING**, and **DANGER**, as used in this manual, alert the reader to important safety considerations. If you have questions, or do not understand the meaning of these terms, do not proceed with the installation. Contact your local dealer, distributor, or call Community directly for assistance.



IMPORTANT: describes an operating condition or user action that may expose the equipment or user to potential damage or danger.



WARNING: describes an operating condition or user action that will likely cause damage to the equipment or injury to the user or to others in the vicinity.



DANGER: describes an operating condition or user action that will immediately damage the equipment and/or be extremely dangerous, or life threatening, to the user or to others in the vicinity.

Rigging and Electrical Safety



DANGER: The loudspeakers described in this manual are designed and intended to be mounted to a variety of building surfaces using certain forms of rigging hardware, means, and methods. Installation of loudspeakers should only be performed by trained and qualified personnel. It is strongly recommended that a licensed and certified professional engineer (PE) or structural engineer approve the mounting plan. Severe injury and/or loss of life may occur if these products are improperly installed! All electrical connections must conform to applicable city, county, state, and national (NEC) electrical codes.



DANGER: All rigging fittings must be fully tightened and secured. Any missing fasteners will compromise the structural integrity of the enclosure and constitute a safety hazard. Do not suspend this loudspeaker unless all fasteners are securely in place!



IMPORTANT: Refer to the sections on installation and connections later in this manual for additional information on rigging and electrical safety.



DANGER: It is possible to experience severe electrical shock from a power amplifier. Always make sure that all power amplifiers are in the "OFF" position and unplugged from the AC Mains supply source before performing electrical work. Many amplifiers use large storage capacitors that are capable of delivering lethal voltages, even when the power cord is unplugged.

PRECAUTIONS & SAFETY CONSIDERATIONS

English

The loudspeakers described in this manual are designed and intended to be 'flown' or suspended for maximum acoustical performance using a variety of rigging hardware, means, and methods. It is essential that all installation work involving the suspension of these loudspeaker products be performed by competent, knowledgeable persons who understand safe rigging practices. Severe injury and/or loss of life may occur if these products are improperly installed. Please read the section on rigging for additional information.

Français

Les haut-parleurs décrits dans ce manuel sont conçus et sont projetés pour être 'volé' ou suspendu pour l'exécution acoustique maximum utilisant une assortiment d'équiper matériel, les moyens, et les méthodes. C'est essentiel que tout travail d'installation ait impliqué la suspension de ces produits d'haut-parleur est exécutée par les personnes compétentes et entraînées qui comprennent équiper les pratiques sûres. La perte sévère de et/ou de blessure de vie peut arriver si ces produits sont incorrectement installés. S'il vous plaît lire la section d'équiper pour l'information supplémentaire.

Deutsch

Die Lautsprecher, die in diesem Handbuch beschrieben werden, sind entworfen und sind zu sein 'geflogen' vorgehabt oder sind für maximale hörbare Leistung verschiedene Manipulierenhardware, Mittel, und Methoden suspendiert benutzend. Es ist wesentlich, dass alle Installationarbeit, die die Aufhängung von diesen Lautsprechernprodukten verwickelt, von fähigen, ausgebildeten Personen durchgeführt werde, die sichere Manipulierenpraxis verstehen. Schwere Verletzung bzw. Verlust des Lebens können stattfinden, wenn diese Produkte unrichtig installiert sind. Bitte lesen Sie den Abschnitt über Manipulieren für zusätzliche Informationen.

Italiano

Gli altoparlanti descritti in questo manuale sono disegnati e sono intesi essere 'volato' o sospeso per la prestazione massima acustica usando una varietà di attrezzature di hardware, i mezzi, ed i metodi. È essenziale che tutta il lavoro di installazione coinvolgendo la sospensione di questi prodotti di altoparlante è eseguita da dalle persone competenti, addestrate che capisce le pratiche di attrezzature di cassaforte. La lesione severa e/o la perdita di vita possono accadere se questi prodotti sono erratamente installati. Per favore di leggere la sezione di attrezzature per le ulteriori informazioni.

Español

Los altavoces descritos en este manual se diseñan y son pensados ser 'volado' o suspendido para el desempeño acústico máximo que utiliza una variedad de aparejar hardware, de medios, y de los métodos. Es esencial que todo trabajo de la instalación que implique la suspensión de estos productos del altavoz sea realizado por personas competentes y entrenada que entienden aparejar seguro las prácticas. La herida y/o la pérdida severas de la vida pueden ocurrir si estos productos se instalan impropriamente. Lea por favor la sección a aparejar para la información adicional.

VERIS 2 OPERATION MANUAL

INTRODUCTION

In 2007 Community introduced the VERIS line of loudspeakers. It rapidly became one of our most successful product families.

Now, in 2012, we have re-engineered the VERIS family and re-named it **VERIS 2**. These all-new loudspeakers retain the size, shape and features that have become highly sought after, following the introduction of the original VERIS line - while simultaneously providing significantly improved performance. Technology marches on... and we've used the best and latest materials, manufacturing techniques and acoustical methodology to improve VERIS 2, without adversely harming the performance-to-price ratio.

Some of the new exciting VERIS 2 technologies include:

- A powerful one-inch High Frequency driver that outperforms anything in its class. The new HF driver also permits lower frequency crossover points, thereby providing better integration with the cone drivers as they approach the crossover region.
- All crossovers have been re-designed and individually voiced to increase uniformity among the various models in the line.
- Models that employ dual cone-drivers, the V2-26 and V2-28, now utilize improved frequency-shading of one of the cone drivers. This improves the polar response, as well as the frequency response, throughout the crossover region.
- The smaller VERIS 2 models, the V2-6, V2-8, V2-26, and V2-28 feature a new rotatable horn design that allows optimal dispersion in either vertical or horizontal positions. Accessed by removing the front grille, the horn may be easily rotated in the field.
- All models in the line feature re-engineered protective front grilles. The new grilles have larger perforated openings that reduce reflective interference without sacrificing structural integrity.

The **VERIS 2** product family includes a new dual 15" subwoofer called the **V2-215S**. Additionally, all full-range models benefit from the introduction of new optional Vertical Yoke Brackets.

OVERVIEW

The ability of VERIS 2 loudspeakers to meet the needs of a broad range of installation requirements, at affordable price points, is truly unmatched. Venues such as nightclubs, cafes, discotheques, houses of worship, auditoriums, lecture halls, restaurants, theatres, and almost anywhere else that people gather to enjoy music or hear the spoken word, are within the ability of the VERIS 2 line to respond with acoustical perfection.

VERIS 2 excels in applications that require controlled coverage patterns, high-impact power response, and intelligible sonic output. VERIS 2 loudspeakers are flexible, easy to install, and most importantly, they provide excellent sound quality.

This manual is intended to help you install VERIS 2 loudspeakers effectively and safely. It provides useful information to assist in obtaining the best sound quality, overall performance, and reliability from VERIS 2 products.

We've provided several easy-to-understand diagrams that enable you to quickly grasp the main features of VERIS 2 loudspeakers; however, we recommend that you take the time to read the entire manual to insure that your VERIS 2 installations meet the highest possible standards of performance and safety standards.

VERIS 2 TECHNOLOGIES

VERIS 2 loudspeakers offer numerous advances in technology that provide superb sound and long-term reliability. Some of these include:

- Sophisticated internal crossover networks for reduced off-axis lobing and consistent coverage throughout the crossover region.
- Carbon Ring Cone Technology. Used on all full-range low-frequency drivers, this patented technology reduces distortion, improves transient response, and provides as much as 30% greater cone area than that of conventional cone drivers of the same rated size.
- Ferrofluid-cooled high-frequency and mid-frequency drivers for improved heat transfer and dramatically reduced distortion by means of viscous damping of the driver's resonant modes.
- Powerful one-inch-throat high-frequency compression drivers offer extended high-end response, smooth output, and lower distortion than previous drivers.
- Non-metallic high-frequency diaphragms provide a further reduction in distortion by eliminating the mechanical resonance normally associated with brittle metallic materials.
- Community's patented Cool-Coil™ *heat evacuation technology* minimizes cone driver power compression and ensures long-term reliability (used in VERIS 2 subwoofers).
- DYNA-TECH™ protection circuitry reduces the likelihood of driver damage under abusive conditions.
- Rugged 11-ply, 18mm cross-laminated Birch enclosures, coated with a two-part catalyzed polyester paint for durability.
- Load-rated threaded rigging fittings on tops, bottoms, and rear of enclosures for safe & easy rigging.
- NL4-compatible locking connector, *plus* a screw-type terminal strip wired in parallel, for easy connectivity.
- Factory designed rigging hardware and mounting brackets - available from stock.
- Smaller models may be ordered with an optional low distortion, low insertion-loss autoformer for 70V and 100V applications.
- All models are available in either black or white finish, at no additional cost.
- **NEW!** Protective steel grilles covered with durable powder-coat finish that also feature increased open space to reduce harmful acoustical reflections.
- **NEW!** Rotatable horns on V2-6, V2-8, V2-26, V2-28.
- **NEW!** Individually voiced crossovers for each model and horn pattern.

UNPACKING AND INSPECTION

VERIS 2 loudspeakers are inherently rugged and are carefully packed in sturdy cartons. However, it is wise to thoroughly inspect each unit after it has been removed from the packaging, as damage could occur during shipping.

Please note that once the shipment has left your dealer or the Community factory, the responsibility for damage is *always* borne by the freight company. If damage has occurred during shipping, you must file a claim directly with the freight company. It is very important to contact the freight company as soon as possible after receiving your shipment, as most freight companies have a short time limit within which they will investigate damage claims. Make sure to save the carton and the packing material, as most claims will be denied if these materials are not retained. Your Community dealer and the factory will try to help in any way they can, but it is the responsibility of the party receiving the shipment to file the damage claim.

It is always a good idea to retain the carton and packing materials indefinitely, if possible, in the event that the unit may need to be returned to your dealer or distributor for repair in the future.

Each shipping carton contains the following items:

- Loudspeaker System (Qty 1)
- Operation Manual (Qty 1)
- Warranty Card (Qty 1)
- VERIS 2 models V2-6, V2-8, V2-26, and V2-28 include a yoke-style mounting bracket at no additional charge.



DANGER: VERIS 2 rigging fittings are rated at a Working Load Limit (WLL) of 100 lbs (45.4kg) with a 10:1 safety margin. No single rigging fitting should ever be subjected to a load that is greater than this stated limit. Failure to heed this warning could result in injury or death!



IMPORTANT: The flat-head Allen-drive rigging screws that come installed in each enclosure must either be replaced with rigging brackets and threaded fasteners, or they must be kept in place to seal the enclosure from air leaks. If the rigging fittings do not remain sealed, air leaks will occur in the enclosure that will compromise the low-frequency performance with distortion, reduced output, and premature driver failure.

VERIS 2 SPECIFICATIONS

Model	V2-6 *	V2-8 *	V2-26 *	V2-28 *	V2-12
Loudspeaker Type	Two-way, full-range, trapezoidal, vented bass	Two-way, full-range, trapezoidal, vented bass	Two-way, full-range, trapezoidal, vented bass	Two-way, full-range, trapezoidal, vented bass	Two-way, full-range, trapezoidal, vented bass
Driver Complement	LF: 1 x 6.5" cone driver HF: 1 x 1" HF driver	LF: 1 x 8" cone driver HF: 1 x 1" HF driver	LF: 2 x 6.5" cone driver HF: 1 x 1" HF driver	LF: 2 x 8" cone driver HF: 1 x 1" HF driver	LF: 1 x 12" HF: 1 x 1"
Nominal Dispersion (H x V)	90° x 70°	90° x 70°	90° x 70°	90° x 70°	V2-1264: 60° x 40° V2-1296: 90° x 60°
Operating Range (-10 dB)	90 Hz - 18 kHz	70 Hz - 18 kHz	70 Hz - 18 kHz	60 Hz - 18 kHz	60 Hz - 18 kHz
Frequency Response (+/- 3 dB)	110 Hz - 16 kHz	100 Hz - 16 kHz	90 Hz - 16 kHz	90 Hz - 16 kHz	90 Hz - 16 kHz
Input Ratings	100W RMS (28.3V) 250W PGM	150W RMS (34.6V) 375W PGM	200W RMS (28.3V) 500W PGM	300W RMS (34.6V) 750W PGM	200W RMS (40V) 500W PGM
Sensitivity 1W/1m (free space SPL) 100 Hz - 12.5 kHz 1/3 octave bands	92 dB	92 dB	92 dB	94 dB	V2-1264: 98 dB V2-1296: 98 dB
Maximum SPL • Continuous • Peak	112 dB cont. 118 dB peak	114 dB cont. 120 dB peak	115 dB cont. 121 dB peak	119 dB cont. 125 dB peak	V2-1264: 121 dB cont. 127 dB peak V2-1296: 121 dB cont. 127 dB peak
Nominal Impedance	8 Ohms	8 Ohms	4 Ohms	4 Ohms	8 Ohms
Crossover Frequency	1.3 kHz	1.3 kHz	1.3 kHz	1.3 kHz	1.3 kHz
Horn Rotatable	YES	YES	YES	YES	NO
Input Connection	NL4-compatible locking connector with terminal strip in parallel	NL4-compatible locking connector with terminal strip in parallel	NL4-compatible locking connector with terminal strip in parallel	NL4-compatible locking connector with terminal strip in parallel	NL4-compatible locking connector with terminal strip in parallel
Rigging Provisions	(9) M6 threaded rigging fittings (4) M6 threaded fittings for V-HSS and third-party suspension products	(9) M6 threaded rigging fittings (4) M6 threaded fittings for V-HSS and third-party suspension products	(9) M6 threaded rigging fittings (4) M6 threaded fittings for V-HSS and third-party suspension products	(9) M6 threaded rigging fittings (4) M6 threaded fittings for V-HSS (4) M8 threaded fittings for third-party suspension products	(13) M10 threaded rigging fittings (4) M8 threaded fittings for third-party suspension products
Construction	18mm, 11-ply cross-laminated birch	18mm, 11-ply cross-laminated birch	18mm, 11-ply cross-laminated birch	18mm, 11-ply cross-laminated birch	18mm, 11-ply cross-laminated birch
Finish	Catalyzed polyester two-part paint, available in black or white	Catalyzed polyester two-part paint, available in black or white	Catalyzed polyester two-part paint, available in black or white	Catalyzed polyester two-part paint, available in black or white	Catalyzed polyester two-part paint, available in black or white
Height	15.54 in (394.8 mm)	17.04 in (432.9 mm)	22.54 in (572.6 mm)	25.54 in (648.8 mm)	23.92 in (607.5 mm)
Width	9.79 in (248.7 mm)	11.29 in (286.8 mm)	9.79 in (248.7 mm)	11.29 in (286.8 mm)	15.37 in (390.4 mm)
Depth	10.15 in (257.8 mm)	11.72 in (297.8 mm)	10.15 in (257.8 mm)	11.72 in (297.8 mm)	14.26 in (362 mm)
Net Weight	19.7 lbs (8.9 kg) 21.7 lbs (9.9 kg) with Autoformer	25.3 lbs (11.5 kg) 27.3 lbs (12.5 kg) with Autoformer	28.1 lbs (12.7 kg) 30.1 lbs (13.7 kg) with Autoformer	36.7 lbs (16.7 kg) 38.7 lbs (17.7 kg) with Autoformer	38.4 lbs (17.4 kg)

* VERIS 2 models V2-6, V2-8, V2-26 and V2-28 include a yoke-style mounting bracket at no additional charge. These four models may be ordered with an optional 200W autoformer to accommodate 70V/100V system designs. Input connections are screw terminals.

Due to ongoing development, specifications are subject to change without notice.

VERIS SPECIFICATIONS (cont'd)

Model	V2-15	V2-32	V2-35	V2-210S *	V2-212S *	V2-215S *
Loudspeaker Type	Two-way, full-range, trapezoidal, vented bass	Three-way, full-range, trapezoidal, vented bass	Three-way, full-range, trapezoidal, vented bass	Dual driver subwoofer, rectangular, vented bass	Dual driver subwoofer, rectangular, vented bass	Dual driver subwoofer, rectangular, vented bass
Driver Complement	LF: 1 x 15" HF: 1 x 1"	LF: 1 x 12" MF: 1 x 6.5" HF: 1 x 1"	LF: 1 x 15" MF: 1 x 6.5" HF: 1 x 1"	LF: 2 x 10"	LF: 2 x 12"	LF: 2 x 15"
Nominal Dispersion (H x V)	V2-1564: 60° x 40° V2-1596: 90° x 60°	V2-3264: 60° x 40° V2-3294: 90° x 40°	V2-3564: 60° x 40° V2-3594: 90° x 40°	360° x 180°	360° x 180°	360° x 180°
Operating Range (-10 dB)	60 Hz - 18 kHz	60 Hz - 18 kHz	55 Hz - 18 kHz	40 Hz - 500 Hz	37 Hz - 500 Hz	37 Hz - 2 kHz
Frequency Response (+/- 3 dB)	80 Hz - 16 kHz	80 Hz - 16 kHz	70 Hz - 16 kHz	50 Hz - 150 Hz	50 Hz - 125Hz	50 Hz - 1000 Hz
Max Input Ratings	200W RMS (40V) 500W PGM	200W RMS (40V) 500W PGM	200W RMS (40V) 500W PGM	300W RMS (34.6V) 750W PGM	300W RMS (34.6V) 750W PGM	400W RMS (40V) 1000W PGM
Sensitivity 1W/1m (free space SPL) 100 Hz - 12.5 kHz 1/3 octave bands	V2-1564: 99 dB SPL V2-1596: 98 dB SPL	V2-3264: 100 dB SPL V2-3294: 99 dB SPL	V2-3564: 100 dB SPL V2-3594: 99 dB SPL	96 dB SPL* (50 Hz - 200 Hz)	98 dB SPL* (50 Hz - 200 Hz)	97 dB SPL* (50 Hz - 200 Hz)
Maximum SPL • Continuous • Peak	V2-1564: 122 dB cont. 128 dB peak V2-1596: 121 dB cont. 127 dB peak	V2-3264: 123 dB cont. 129 dB peak V2-3294: 122 dB cont. 128 dB peak	V2-3564: 123 dB cont. 129 dB peak V2-3594: 122 dB cont. 128 dB peak	121 dB cont. 127 dB peak	123 dB cont. 129 dB peak	123 dB cont. 129 dB peak
Nominal Impedance	8 Ohms	8 Ohms	8 Ohms	4 Ohms	4 Ohms	4 Ohms
Crossover Frequency	1.3 kHz	600 Hz / 3 kHz	600 Hz / 3 kHz	N/A	N/A	N/A
Horn Rotatable	No	Yes	Yes	N/A	N/A	N/A
Input Connection	NL4-compatible locking connector with terminal strip in parallel	NL4-compatible locking connector with terminal strip in parallel	NL4-compatible locking connector with terminal strip in parallel	NL4-compatible locking connector with terminal strip in parallel	NL4-compatible locking connector with terminal strip in parallel	NL4-compatible locking connector with terminal strip in parallel
Rigging Provisions	(13) M10 threaded rigging fittings (4) M8 threaded fittings for third-party suspension products	(13) M10 threaded rigging fittings (4) M8 threaded fittings for third-party suspension products	(13) M10 threaded rigging fittings (4) M8 threaded fittings for third-party suspension products	(8) M10 threaded rigging fittings	(8) M10 threaded rigging fittings	(8) M10 threaded rigging fittings
Construction	18mm, 11-ply cross-laminated birch	18mm, 11-ply cross-laminated birch	18mm, 11-ply cross-laminated birch	18mm, 11-ply cross-laminated birch	18mm, 11-ply cross-laminated birch	18mm, 11-ply cross-laminated birch
Finish	Catalyzed polyester two-part paint, available in black or white	Catalyzed polyester two-part paint, available in black or white	Catalyzed polyester two-part paint, available in black or white	Catalyzed polyester two-part paint, available in black or white	Catalyzed polyester two-part paint, available in black or white	Catalyzed polyester two-part paint, available in black or white
Height	27.17 in (690.1 mm)	29.29 in (744 mm)	32.42 in (823.4 mm)	11.91 in (302.7 mm)	13.91 in (353.5 mm)	18.41 in (467.8 mm)
Width	18.37 in (466.5 mm)	17.37 in (441.1 mm)	18.37 in (466.5 mm)	32.66 in (829.7 mm)	35.91 in (912.3 mm)	37.41 in (950.4 mm)
Depth	15.91 in (404 mm)	15.36 in (390 mm)	15.91 in (404 mm)	15.91 in (404.3 mm)	17.91 in (455.1 mm)	20.37 in (517.5 mm)
Weight	47.8 lbs (21.7 kg)	54.1 lbs (25.4 kg)	59.5 lbs (27 kg)	58 lbs (26.3 kg)	70 lbs (31.8 kg)	94 lbs (42.6 kg)

* All subwoofer measurements are performed at half-space.

Due to ongoing development, specifications are subject to change without notice.

GETTING ACQUAINTED

Figure 1: Physical Features of a Typical VERIS 2 Full-Range Model

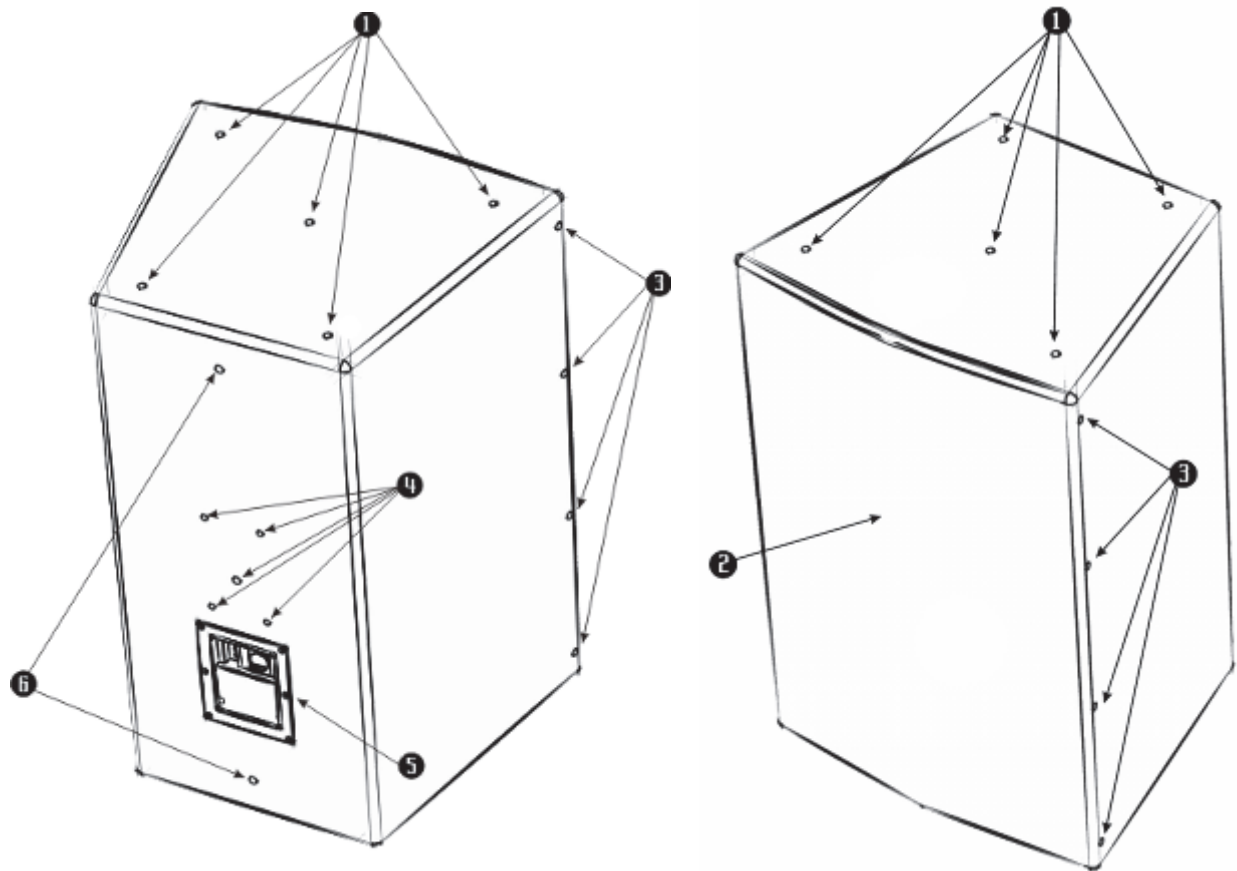

PHYSICAL FEATURES OF VERIS 2 FULL-RANGE MODELS

FEATURE	DESCRIPTION
1 TOP & BOTTOM RIGGING POINTS	M6 or M10 threaded fittings, depending on model.
2 PROTECTIVE GRILLE	Powder-coated steel grille protects drivers from foreign objects.
3 GRILLE RETENTION SCREWS	#6 x 5/8" sheet metal screws. Remove grille to service drivers.
4 THREADED FITTINGS FOR THIRD-PARTY MOUNTING DEVICES	Fits third-party 30lb or 60 lb speaker mounts, depending on model.
5 INPUT PANEL	For amplifier connection to the loudspeaker. NL4 and terminal strip are wired in parallel.
6 REAR PULL-BACK POINTS	Used for angling enclosure downward; not intended for primary rigging.

Figure 2: Physical Features of a Typical VERIS 2 Subwoofer

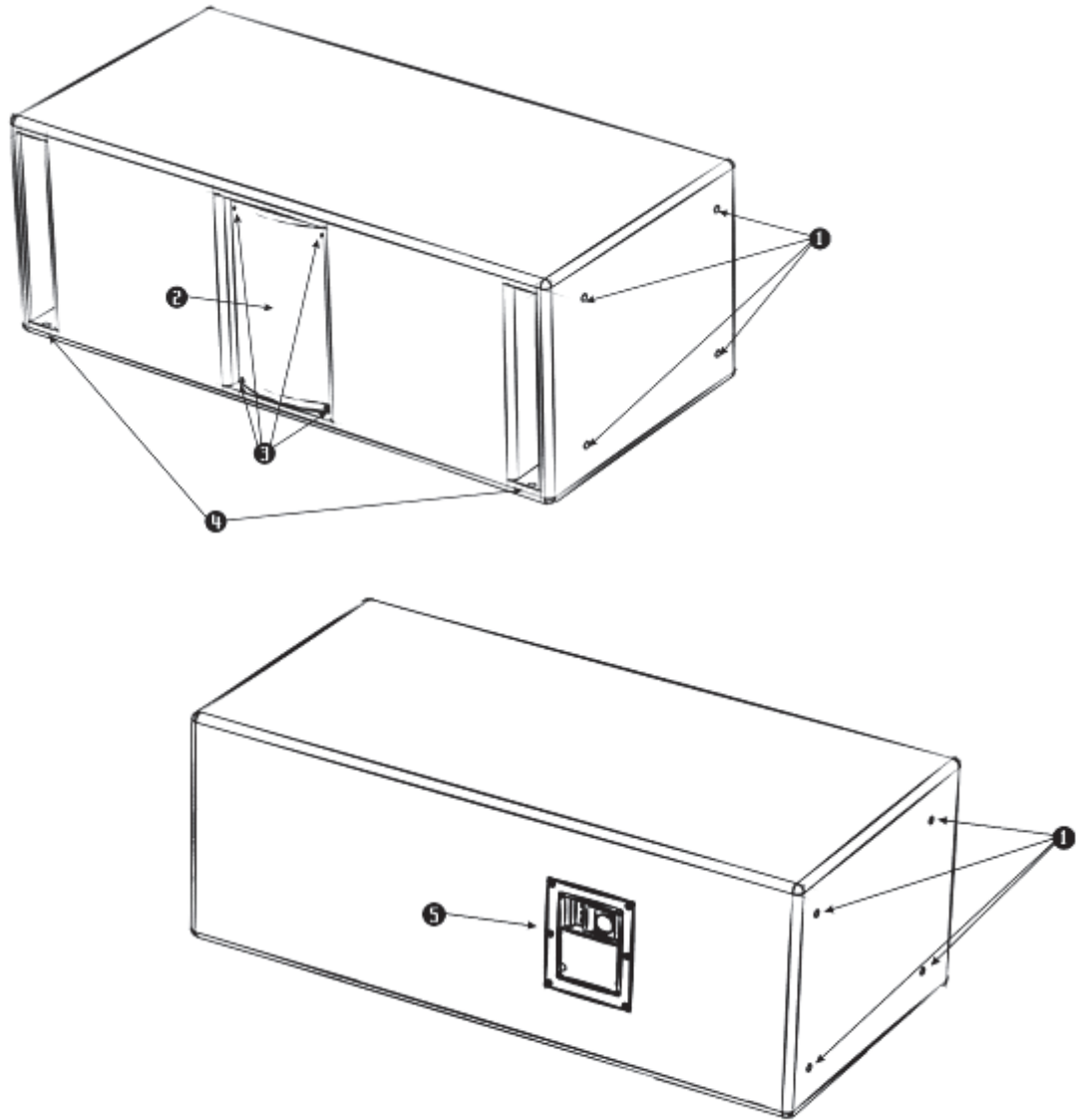

PHYSICAL FEATURES OF VERIS 2 SUBWOOFERS

FEATURE	DESCRIPTION
①	RIGGING POINTS M10 threaded fittings. Four (4) on each side panel.
②	PROTECTIVE GRILLE Powder-coated steel grille protects drivers from foreign objects.
③	GRILLE RETENTION SCREWS #6 x 5/8" sheet metal screws. Remove grille to service drivers.
④	FEET Four rubber feet protect surfaces from marring.
⑤	INPUT PANEL For amplifier connection to the loudspeaker. NL4 and terminal strip are wired in parallel.

GENERAL DESCRIPTION

VERIS 2 Series loudspeakers are designed for demanding day-to-day use in a wide range of fixed installations. Their high quality driver components are housed in rugged, acoustically inert enclosures equipped with rigging fittings. VERIS 2 systems are characterized by a high-power, low distortion linear response that provides exceptional musicality and speech intelligibility.

The VERIS 2 line consists of the 11 models briefly described below:

- **V2-6** - a 6.5" / 1" two-way in a trapezoidal enclosure with rotatable HF horn.
- **V2-8** - an 8" / 1" two-way in a trapezoidal enclosure with rotatable HF horn.
- **V2-26** - a dual 6" / 1" two-way in a trapezoidal enclosure with rotatable HF horn.
- **V2-28** - a dual 8" / 1" two-way in a trapezoidal enclosure with rotatable HF horn.
- **V2-12** - a 12" / 1" two-way in a trapezoidal enclosure with a choice of 60° x 40° or 90° x 60° horn patterns.
- **V2-15** - a 15" / 1" two-way in a trapezoidal enclosure with a choice of 60° x 40° or 90° x 60° horn patterns.
- **V2-32** - a 12" / 6.5" / 1" three-way in a trapezoidal enclosure with a choice of 60° x 40° or 90° x 40° horn patterns. Horn is rotatable.
- **V2-35** - a 15" / 6.5" / 1" three-way in a trapezoidal enclosure with a choice of 60° x 40° or 90° x 40° horn patterns. Horn is rotatable.
- **V2-210S** - a dual 10" subwoofer in a rectangular enclosure.
- **V2-212S** - a dual 12" subwoofer in a rectangular enclosure.
- **V2-215S** - a dual 15" subwoofer in a rectangular enclosure (**NEW!**).

Note: the specification tables on pages 9 and 10 depict the dimensions, weights, and detailed performance specifications of the eleven VERIS 2 models described above.

VERIS 2 loudspeakers may be used in multiples, forming clusters and arrays. Systems may be designed around horizontal splayed arrays, vertical splayed arrays, as well as exploded clusters and distributed configurations. Rigging kits are available from the factory as standard items.

DYNA-TECH™ DRIVER PROTECTION SYSTEM

All VERIS 2 Series loudspeakers employ Community's advanced technology DYNA-TECH driver protection system. Functioning as a multi-stage limiter, DYNA-TECH circuitry provides precise and repeatable protection by reducing excessive power to the drivers under abusive conditions.

The first stage of limiting is designed to protect against short-term excess power applied to the high-frequency driver(s) in the system. This circuit utilizes an HPCCR (High Positive Current Coefficient Resistor) in series with the driver(s). The HPCCR increases resistance as the current flowing through it increases. As its resistance rises above nominal, the heating of the element provides RMS conversion. The result is an RMS limiter with a ratio that varies according to the demands of the program material.

The second stage of limiting protects against excessive power levels to *all* drivers in the system. This stage is based on an electro-mechanical relay driven through a voltage sensing circuit. The relay engages at a pre-determined voltage, corresponding to a power level that would otherwise cause driver damage. When engaged, the relay introduces a bank of high-wattage resistors in series with the drivers. These resistors cause a voltage drop to the drivers, thereby reducing the power applied to them. A red LED on the rear panel indicates that this protection circuit has been engaged.

When the relay protection circuit is activated, there will be a noticeable drop in the system's level (approximately 3 to 4 dB). The red LED, as well as the drop in level, serves as a warning to the operator that the loudspeaker is being overdriven. **When this stage of protection is engaged, the level of the console and/or the amplifier's output to the system should be reduced.**



IMPORTANT: If the operator continues to run the system at excessive levels, or worse, if the operator raises the drive level to compensate for the drop in output caused by the protection circuitry, eventually an additional stage of protection will engage that shuts down the system entirely (note that this additional stage of protection will never engage until *after* the second stage has been triggered). If the system shuts down entirely, the operator can immediately restore sound by simply reducing the drive level to the system.

Advantages of Community's DYNA-TECH Circuitry

There are numerous advantages to this type of multi-stage protection circuitry. The trip point is pre-set to engage at exactly the same time on all speakers that are powered from the same amplifier. The initial stages of DYNA-TECH protection circuitry do not rely on, and are not affected by heat build-up. Some manufacturers use circuit breakers that require heat build-up before they trip; this limits their ability to protect a cold speaker. The trip points of such breakers are also affected by ambient temperature, their own internal heating curves, and small variations in speaker impedance or crossover component tolerances, all of which can cause unpredictable behavior.

Because the first and second stages of Community's DYNA-TECH circuits are not thermally sensitive, they react nearly instantaneously to protect against an excessive increase in level. Moreover, the protection disengages almost immediately when the drive level to the system is reduced; it is not necessary to wait for a circuit breaker to cool down. This means that your loudspeaker can operate at its full dynamic range and still react quickly to protect against excessive musical peaks, avoiding damage to the system. It also means that your loudspeaker is protected from the moment the power amplifier is plugged in and turned on, regardless of the ambient temperature.

As mentioned above, the protection circuitry provides a third level of protection for the entire loudspeaker to guard it from severe misuse. If the system is operated in the second-stage mode of protection for a long period of time, or if the input level is increased to try to overcome the volume drop from the second-stage protection circuitry, a solid-state circuit breaker will trip and remove all signal from the loudspeaker until the input level is reduced. Because this circuit breaker *is* heat sensitive, it provides a final level of protection that takes heat into account as well as power. However, unlike most implementations of circuit breakers that take time to cool down before resetting, DYNA-TECH circuits respond instantly to a reduction in level, restoring the system to its full dynamic range without needing to wait for the circuit breaker to reset itself.

COOL-COIL™ TECHNOLOGY

The cone drivers used in the VERIS 2 subwoofers utilize Community's patented Cool-Coil™ heat evacuation technology. A proprietary process, Cool-Coil employs an airflow director to remove heat from the voice coil, thereby increasing both the performance and reliability of the cone drivers. In particular, the effect of Power Compression is significantly improved by Cool-Coil technology. Power Compression occurs when drivers respond non-linearly to applied power, producing less and less output as their voice coils heat up and their impedance rises.

High voice coil temperatures have other undesirable effects on performance. Most materials used in drivers, particularly adhesives and insulation, suffer some diminished properties under extremes of heat. Thermal expansion can result in warpage and misalignment of components. A voice coil in which the diameter has increased due to thermal expansion will often no longer be round, and certainly has a greater possibility of rubbing against the magnetic structure.

Any amount of cooling that can be applied to a woofer will be beneficial. One very commonly used cooling method is venting of the pole piece of the magnet structure. The motion of the cone assembly will pump air in and out of the cavity under the dust cap. This air passing through the pole vent helps to cool the magnet structure. Community has improved on this common cooling method by introducing an airflow director (US patent 6,390,231) into the air path. Figure 3 shows a conventional woofer motor with a vented pole piece, and also a similar motor with the addition of an airflow director. The voice coil former in the airflow motor is aluminum, and is taller than normal. This extended aluminum former becomes a cooling fin

for the voice coil, and the airflow director causes the air to pass in close proximity to the former. By directing the air to flow over the hot aluminum former, more heat is removed from the voice coil than simply allowing the pumped air to take its natural path in and out of the cavity. This results in woofers that can handle higher power with greater reliability than those of conventional design.

Figure 3: Community's Cool-Coil™ Heat Evacuation System

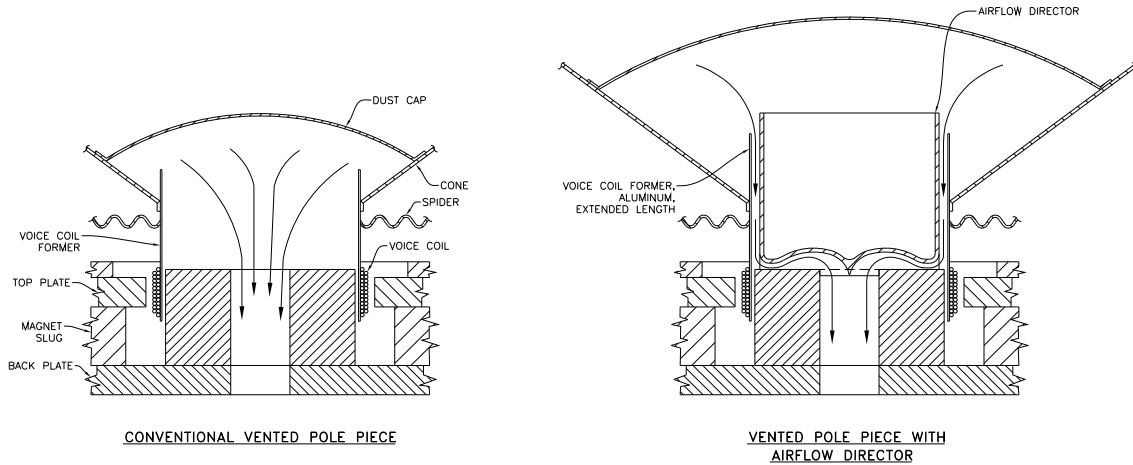

HIGH-PASS FILTERS

We strongly encourage the use of an external, active high-pass filter to protect the cone drivers from excessive low-frequency excursion. A high-pass filter will eliminate the potential of low-frequency modulation from wind noise, turntable rumble, stage vibration, and other causes that result in a poorly defined and 'muddy' bass response. Additionally, a high-pass filter will avoid wasting amplifier power by keeping the amplifier from attempting to reproduce frequencies below the loudspeaker's intended operating range. The table below shows the recommended filter settings:

Model	High-Pass Filter
V2-6 Full-Range	100 Hz, 24db/octave
V2-8 Full-Range	90 Hz, 24db/octave
V2-26 Full-Range	80 Hz, 24db/octave
V2-28 Full-Range	70 Hz, 24dB/octave
V2-12 Full-Range	60 Hz, 24db/octave
V2-15 Full-Range	60 Hz, 24db/octave
V2-32 Full-Range	60 Hz, 24db/octave
V2-35 Full-Range	60 Hz, 24db/octave
V2-210S Subwoofer	40 Hz, 24db/octave
V2-212S Subwoofer	40 Hz, 24db/octave
V2-215S Subwoofer	35 Hz, 24db/octave

CONNECTING THE AMPLIFIER TO THE LOUDSPEAKER

All VERIS 2 Series loudspeakers are provided with two methods of connecting the amplifier to the loudspeaker. One is an industry standard NL4 type locking connector, and the other is a pressure-screw terminal strip. These two connectors are wired in parallel with each other, on all models.

Figure 4: VERIS 2 Input Panel

The following figure is an example of a typical input panel used on VERIS 2 loudspeakers. A similar panel is used on all standard, low impedance VERIS 2 models. The loudspeaker is intended to be connected directly to the amplifier.

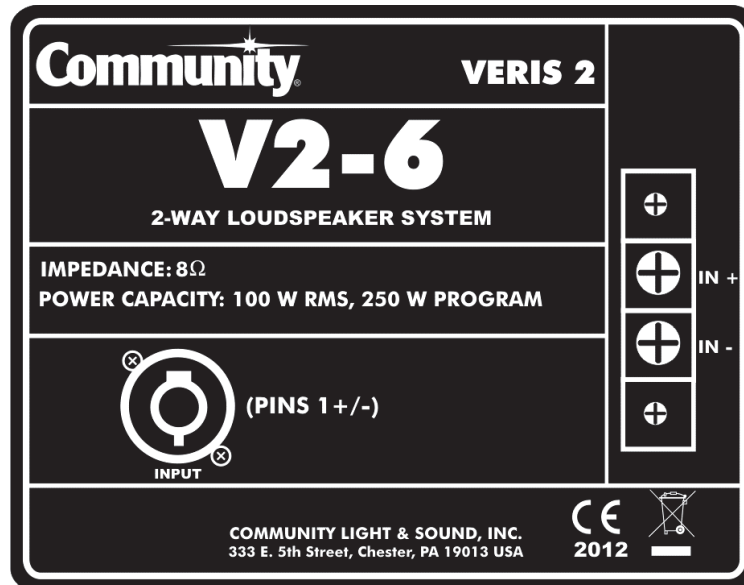

Typical Standard Input Panel

PIN DESIGNATIONS

For all models the pin designation is as follows:

- **NL4 Pin 1+** or the terminal screw labeled (+) connect to the positive (red) output of the amplifier.
- **NL4 Pin 1-** or the terminal screw labeled (-) connect to the negative (black) output of the amplifier.

Note that the NL4 and the terminal strip are wired in parallel, and that Pins 2+ and 2- on the NL4 connector are not utilized.



CAUTION: Be sure to carefully observe polarity when wiring your loudspeakers. If one loudspeaker is wired with the opposite polarity from another loudspeaker, acoustic cancellation will occur. The result will be less acoustic power output than if only one loudspeaker were used by itself.

Figure 5: VERIS 2 Input Panel, Optional Autoformer Version

The following figure is an example of the input panel used on VERIS 2 loudspeakers equipped with an optional autoformer. Such models are intended to be used in a 70V or 100V "constant voltage distribution system."

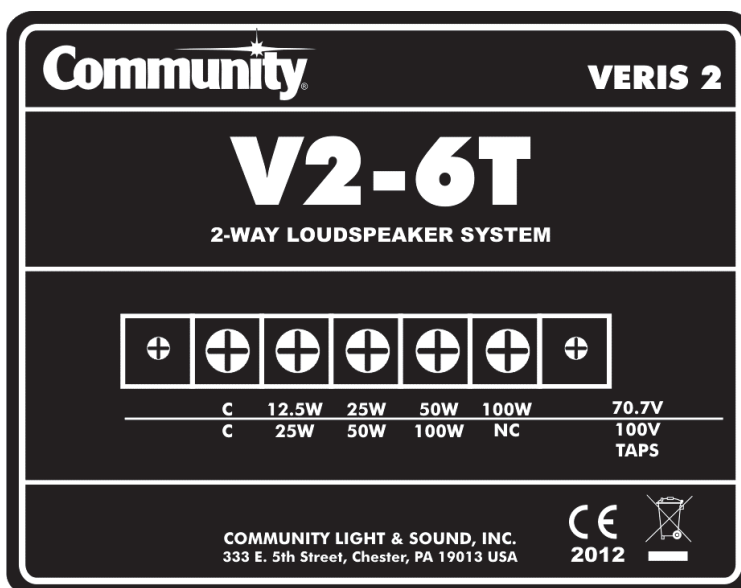

Typical Input Panel for Autoformer Equipped Models

PIN DESIGNATIONS

The pin designation is as follows:

- 'C' (meaning 'Common') connects to the 'C' or Ground connection on the amplifier (typically a black binding post, or the 1- pin of an NL4 type connector).
- The selected tap connects to the positive output of the amplifier (typically a red binding post, or 1+ on an NL4 type connector).

USING POWER TAPS

A VERIS 2 loudspeaker equipped with an optional autoformer has four 70.7V taps and three 100V taps. The 70.7 volt taps are set at 25W, 50W, 100W and 200W on the two larger models, and 12.5W, 25W, 50W and 100W on the two smaller models. The 100V taps are set at 50W, 100W and 200W on the two larger models, and 25W, 50W, and 100W on the two smaller models.

By choosing one of the taps, you can govern how much amplifier power is available for each loudspeaker. For example, if the 50W tap is selected, that particular loudspeaker will draw 50 watts of power when a 70V amplifier is run at its maximum level. A second loudspeaker might be connected to the same amplifier, but tapped at 100W. In such case the second loudspeaker will draw 100 watts from the same amplifier, making it 3 dB louder than the first loudspeaker. A third loudspeaker might be tapped at 200 watts, which would make it 3 dB louder than the second loudspeaker, and 6 dB louder than the first.

By using the various taps, the installer can balance the relative sound levels in a system. A loudspeaker that is closer to audience members will need to be tapped at a lower wattage than one that is farther away, in order to produce similar sound levels.

Typically, every time you double the distance from a sound source, the level drops by 6 dB, which is equivalent to one-fourth of the power. Although this is an acoustical law, and is true in a free space environment such as outdoors, the effect of room acoustics can (and usually will) change the actual results. Even outdoors, it is normally not possible to validate this acoustical law using a sound level meter, due to the ground plane effect.

That said, the use of pink or white noise to excite the system, and a sound level meter to take nearfield measurements, will help the installer to precisely balance the relative level of each loudspeaker in a sound system. Just make sure to take your readings at an identical distance from each of the loudspeakers in the system, otherwise the results will be skewed.

70.7V and 100V SYSTEMS

Several voltage standards have been put in place regarding so called 'constant voltage systems.' In the United States, 25V, 70.7V and 100V are common. Occasionally 140V systems can be found, usually in very large venues such as racetracks, where the need to overcome cable resistance by scaling-up the voltage becomes extremely important. In Europe and Asia most constant voltage systems use the 100V standard; in the USA the 70.7 voltage standard is most often utilized.

A VERIS 2 loudspeaker equipped with the optional autoformer will support both the 70.7V and 100V standards. The same screw terminals are used for both voltage standards, but the power level of the tap is different, depending on whether the amplifier voltage is 70.7V or 100V. Note that on the rear input panel, the power levels *above* the horizontal line refer to a 70.7V system, while the power levels *below* the line refer to a 100V system.

A 100V system will produce twice the power at a given tap, as that of a system run at 70.7 volts. This can be verified by the simple Ohm's Law calculation $E^2/Z = W$, where E is the voltage applied, Z is the load impedance, and W is the power expressed in Watts. Assuming a load impedance of 50 ohms, we can see that $70.7 \times 70.7 / 50 = 99.97$ and that $100 \times 100 / 50 = 200$. Therefore, when scaling up from 70.7V to 100V the power will double; when scaling down, the power will halve.



CAUTION: Be sure to carefully observe polarity when wiring your loudspeakers. If one loudspeaker is wired with the opposite polarity from another loudspeaker, acoustic cancellation will occur if the loudspeakers share the same acoustic space. The result will be **less** power output than if only one loudspeaker were used by itself.



TIP: When using the barrier strip for wiring, we recommend that you first terminate the wire with a plated copper crimp-type spade lug, using moderate to heavy pressure on the crimp tool. When the spade lug is tightened firmly on the barrier strip it will form a gas-tight connection resistant to corrosion. Be careful not to over-tighten the barrier strip screws, as they can shear off under too much torque. This is the recommended method of wiring for fixed installations, especially those that may be exposed to inclement environmental conditions.

WIRING NL4 TYPE CONNECTORS

The following diagram shows how connections are made to an NL4 type of loudspeaker connector. Terminations may be soldered, or made by means of their built-in screw and pressure clamp. If using the pressure clamp, it's important to tighten it fully, then to wait about ten minutes (longer is better), then to tighten it again. This is because copper wire *flows* under pressure. After initially tightening the screw clamp, some minutes later the screw will no longer be as tight due to the effect of the compression on the copper. Typically, only one cycle of "tighten - wait - re-tighten" is required for a secure connection.

Figure 6: NL4-Type Connector

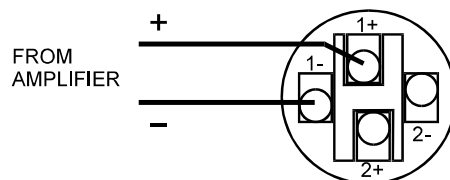

**NEUTRIK SPEAKON™
CONNECTOR – NL4FC**

Note: Pins 2+ and 2- are not used in VERIS 2 loudspeakers.



DANGER: When wiring the amplifier(s) to the loudspeaker(s), always power-down the amplifier(s) and disconnect their AC Mains plug(s). Many modern, high power amplifiers can deliver enough voltage and current to cause a harmful or lethal electric shock. Shocks from very low frequencies, such as kick drums, can cause the human heart to stop beating at relatively low power levels.



WARNING: After wiring the amplifier(s) to the loudspeaker(s), first power up all devices that are upstream of the amplifier, such as mixers, equalizers, compressor/limiters, etc., **before** powering-up the amplifier. This avoids passing any transient 'clicks' or 'pops' that may originate in the upstream devices to the loudspeakers. The amplifier should initially be powered-up with its gain controls turned all the way down. After making sure that a continuous signal is present, such as a CD playing, slowly raise the level of the gain controls to establish that the wiring has been installed correctly. Only then should the loudspeaker be operated at normal output levels.

KNOW YOUR AMPLIFIER

Not all amplifiers can safely drive low-impedance loads, though usually 4 ohms and higher is not a problem. Very low impedance loads may cause the amplifier to clip prematurely, overheat, shutdown, or fail altogether due to internal device damage.

Even when an amplifier is quite stable driving a low impedance load, cable loss will be greater than with moderate impedance loads, damping factor will be reduced, and if the amplifier were to fail, a larger portion of the sound system is likely to be taken off-line due to the fact that a low impedance load implies a larger number of loudspeakers being powered from a common amplifier.



TIP: Keeping the loads at 4 ohms or higher will lengthen the life of your amplifier(s) and improve the reliability and overall sound quality of the system.

CHOOSING LOUDSPEAKER WIRE

Wire and cable is used to transfer power between the amplifier and the loudspeaker. Wire and cable can be purchased with copper and aluminum conductors; for loudspeakers only copper conductors should be utilized.

The construction, conductor type, and insulation material of wire and cable vary widely. Wire can be purchased with solid core construction, stranded core construction, and densely stranded construction. Cables are typically available only as stranded or densely stranded.

Speakers may be driven through individual conductors bundled together and pulled through conduit, or through a cable made up of a number of conductors covered with an overall jacket, which then may or may not necessarily be installed in a conduit. Wire and cable manufacturers offer multi-conductor cables with 30 or more high current conductors covered with a variety of jacket types. Jackets may be made of PVC, rubber, neoprene, and other materials, depending on the intended conditions of use.

Generally speaking, the wires and cables that power loudspeakers do not need to be twisted into pairs, though there is some benefit to doing so. A twisted pair of conductors has the effect of cancelling electro-magnetic radiation, thereby reducing mutual induction among circuits that share the same physical space (such as a cable tray or conduit), along with canceling the crosstalk that might otherwise result.

Twisted pairs are commonly used for balanced line signal and microphone cables, in which the nominal voltages are very low and the input impedance of the load is typically quite high (>10K ohms). Under such conditions, the use of a twisted pair is essential to reduce crosstalk among adjacent cables. The twisting insures that the differential amplifier in a balanced line receiver will see identical phase and amplitude of any extraneous Electro Magnetic Interference (EMI) induced in the cable on both polarities, thereby allowing the EMI to be differentially cancelled.

In contrast, however, loudspeakers have input impedances that are quite low and operate on much higher voltages. The potential of inducing an audible signal from adjacent wiring is close to zero. The installer may, however, choose to use twisted pair loudspeaker cable for other reasons. Certain amplifiers may exhibit instability when driving long lengths of wire installed in conduit. A twisted pair will insure that the reactance of the loudspeaker cable is identical on both the plus and minus wires, thereby presenting a more stable load to the amplifier. Note that when specifying multiple twisted pairs of speaker cables intended to share the same conduit, the conduit will need to be sized much larger than with loose or bundled conductors.

CONDUCTORS AND INSULATION

Solid conductor wire is slightly less expensive than stranded wire, but much more difficult to pull through conduit. Also, it does not terminate to most speaker connectors as easily as stranded wire. Therefore, we recommend using stranded THHN type wire for installations that involve conduit.

Densely stranded cables, typically used for portable cordage, will coil up easily and lay flat on the stage, making them a good choice for applications requiring portability such as floor monitors. Typical examples are 14/2 and 14/4 SJO. Such cable is normally stocked in many hardware stores.

Wire and cable **insulation** is always rated for a working voltage and a maximum temperature. In power distribution systems, wire and cables can get very hot, making the temperature rating extremely important. When used with loudspeakers, the temperature of the wire or cable will hardly ever rise more than 10° C above ambient, and voltages will never exceed 300V (which is the *minimum* rating of most industrial wire and cable).

Special cables are manufactured for installation in air plenums, while others are made for direct burial. Use of such products can save a lot of time and expense compared to installing conduit. However, local, state, or federal building codes may require that loudspeaker cables are installed in conduits or in cable trays. Therefore, it's a good idea to check applicable regulations carefully, before beginning any installation.

In the United States, conductors are sized according to a numbering system known as the American Wire Gauge, or AWG. Larger numbers, such as #22 or #24 indicate smaller diameter wire, while smaller numbers such as #10 and #12 indicate larger diameter wire. In other parts of the world, the metric system is widely used to define conductor diameter. Metric equivalents can be converted to US AWG sizes, with only a small loss of precision.

The larger the diameter of the conductor, the lower the resistance will be for a given length. Resistance is normally stated *per foot*, or *per hundred feet* of wire. For example, #10 stranded copper THHN has a resistance of .204 ohms per hundred feet, though this can vary slightly among manufacturers.

The resistance of the wire, the impedance of the load, and the output voltage of the amplifier will determine how much loss occurs in the wire. These parameters also govern the damping factor of the amplifier/speaker combination (more on this later).

Below is a table that gives a quick look at the effect of wire size on line loss. These numbers assume that the amplifier is producing a constant 48 Volts at its output terminals, which is equivalent to 288 watts into an 8Ω load or 576 watts into a 4Ω load:

Size	Length	Load Z	Loss in dB
#10 AWG	100'	8Ω	-0.42 dB
#10 AWG	200'	8Ω	-0.83 dB
#10 AWG	100'	4Ω	-0.83 dB
#10 AWG	200'	4Ω	-1.58 dB
#12 AWG	100'	8Ω	-0.66 dB
#12 AWG	200'	8Ω	-1.28 dB
#12 AWG	100'	4Ω	-1.28 dB
#12 AWG	200'	4Ω	-2.39 dB
#14 AWG	100'	8Ω	-1.03 dB
#14 AWG	200'	8Ω	-1.95 dB
#14 AWG	100'	4Ω	-1.95 dB
#14 AWG	200'	4Ω	-3.55 dB

The worst-case scenario shown above is the 200' run of #14 AWG into a 4 ohm load. This will result in a staggering loss of -3.55 dB, or more than half of the amplifier's total power output. Use of wire that's one size smaller, #16 AWG, would cause a power loss of -5.11 dB. This approaches a 75% loss of total available power! As you can readily see, it's very important to use the largest gauge wire that you possibly can, particularly when long lines are unavoidable. Note: NL4-compatible connectors easily accept #12 AWG.



TIP: When choosing cable for a situation that requires only two conductors, consider using 14/4 (that is, #14 AWG with 4 conductors) and wiring each pair of conductors in parallel, at both ends of the cable. This will provide the equivalent conductance of #11 AWG, but in a cable that's more easily obtainable and smaller in diameter.

THE EFFECT OF WIRE GAUGE ON DAMPING FACTOR

As significant as power loss can be, the effect of wire resistance on the damping factor of the loudspeaker/amplifier network is even greater for a given resistance value.

Amplifier designers intend for the output impedance of their amplifiers to be as low as possible, in order to achieve a high damping factor. However, the laws of physics dictate that a very low output impedance will cause the resistance of the speaker cable to have a significant effect on the amplifier/speaker network. Unfortunately there's no way to get around it.

Example: With five feet of #10 AWG feeding a 4 ohm load, a given amplifier exhibits a respectable 100:1 damping factor. With fifty feet of #10 AWG feeding the same 4 ohm load, the damping factor decreases to 10:1, which is likely to be audible as a loss of 'punch' and tightness in the low frequencies.

Unless the power amplifiers are located directly alongside the loudspeakers (a good design technique to consider when possible), it will be difficult to maintain a high damping factor without using impractically large conductors. Therefore, keeping cable lengths as short as possible, is the most practical and cost-effective way to maintain a respectable damping factor without incurring undue difficulties.



TIP: Although it's beyond the scope of this manual to test and rate the many specialty loudspeaker cables sold in audio shops, studies conducted by skilled engineers have conclusively shown that the majority of such cables offer no real performance advantages (and in some cases, notable disadvantages) over that of readily available industrial grade wire.

SELECTING AMPLIFIERS

Amplifiers are a vital part of any sound system's performance capability. As such, they should be carefully selected for appropriate power output, as well as for other attributes (more on this later). A table is provided below to help you size your amplifiers' power output capability to the various models in the VERIS 2 line.

Model	Recommended Power
V2-6 Full-range	200 to 300 WRMS at 8Ω
V2-8 Full-range	310 to 450 WRMS at 8Ω
V2-6 Full-range	420 to 600 WRMS at 4Ω
V2-8 Full-range	630 to 900 WRMS at 4Ω
V2-12 Full-range	420 to 600 WRMS at 8Ω
V2-15 Full-range	420 to 600 WRMS at 8Ω
V2-32 Full-range	420 to 600 WRMS at 8Ω
V2-35 Full-range	420 to 600 WRMS at 8Ω
V2-210S Subwoofer	630 to 900 WRMS at 4Ω
V2-212S Subwoofer	600 to 900 WRMS at 4Ω
V2-215S Subwoofer	900 to 1200 WRMS at 4Ω

Note: "WRMS" = "Watts RMS" = "Watts Root Mean Squared"

VERIS 2 APPLICATIONS

To select the most appropriate VERIS 2 product(s) for your application, the initial factors to consider are the size of the venue, the style of music and speech to be reproduced, and the location(s) of the loudspeaker(s).

In smaller venues with less demanding musical styles, one can usually achieve excellent results with the V2-12 and the V2-15 models. A good rule of thumb is to use a pair of these models for venues that host up to approximately 200 persons.

By adding a second pair of either the V2-12 or V2-15, venues that host as many as 300 to 400 persons can be effectively covered. Each pair of enclosures may be configured side-by-side or one over the other, to produce additional forward radiated power.

In rooms that are particularly wide - but shallow in depth, such as fan-shaped churches - a second pair may be required simply to obtain the necessary horizontal coverage, even if overall power is not an issue.

The V2-15, with its 15" cone driver, will provide additional low-frequency content than that of the V2-12, which has a 12" cone driver, resulting in a richer, fuller response. However, if either model is to be used with subwoofers, such as the V2-210S, V2-212S, or V2-215S, the difference in the response between the V2-12 and the V2-15 will be minimized.

V2-32 and V2-35 models are true three-way designs, employing horn loaded mid-range drivers in addition to their horn loaded high-frequency drivers. This design yields better directional control than a two-way system. The added directionality is an asset in reverberant rooms where it's important to keep the sound energy off of the walls, floor and ceiling, and/or when there's a need to cover long distances, either indoors or out.

The larger V2-35 with its 15" cone driver will provide deeper low-frequency response than that of the V2-32 which employs a 12" cone driver, but here again the difference in response will be minimal if either model is used with a VERIS 2 subwoofer.

The small V2-6 and V2-8 loudspeakers are ideal for small rooms (25 – 75 persons), as well as for distributed systems in large rooms. They can also be used as 'delay speakers,' augmenting a larger system to balance out the levels from the front of the room to the rear of the room. The practice of driving small speakers through a delay line is used in many theatrical systems, concert hall systems, and houses of worship. It gives the installer a powerful tool when it comes time to equalize and balance the system.

In large rooms, and especially those in which the acoustical conditions are not ideal, we strongly recommend the use of under-balcony delay speakers, over-balcony delay speakers, front fill speakers, etc. In areas of the room that are too far away from the primary loudspeaker(s) to enjoy clear intelligibility, the addition of local, delayed speakers can do wonders in solving problems.

The V2-26 and V2-28 models provide twice the woofer cone area of their smaller cousins. The second woofer cone provides more overall power with greater bass response. These models are a good choice for distributed music systems, such as in health clubs, bars, restaurants and the like.

New! The VERIS 2 line now has the ability to rotate the HF horn to change the axes of widest and narrowest HF dispersion. This new feature applies to V2-6, V2-8, V2-26 and V2-28 models. The distinctive advantage is that the loudspeaker can now be located and installed in a physical orientation that best suits the architectural requirements and room décor, without compromising the loudspeakers' acoustical dispersion characteristics.

New! The VERIS 2 line now includes three subwoofers (previously only two models). The V2-210S employs dual 10" drivers, while the V2-212S utilizes dual 12" drivers, and the all-new V2-215S features dual 15" cone drivers. The new V2-215S provides the additional power and depth-of-response that's needed for larger clubs, houses of worship, and other venues, while still retaining the 'punch' and 'tight response' that VERIS subwoofers have come to be known for.

All three models add extended low-frequency response and increased power to the VERIS 2 full-range loudspeaker(s) that they are intended to be used with. By removing the LF power demand from the full-range VERIS 2 models - and transferring much of the LF requirements over to the subwoofer(s), the entire system benefits significantly.

The smallest subwoofer, the VERIS 2-210S, is characterized by an exceptionally tight and punchy sound. The larger VERIS 2-212S adds a deeper low end, but still with a very rapid transient response. The new VERIS 2-215S remains capable of clean and responsive bass reproduction, but with greater power and depth than its smaller siblings.

When using multiple subwoofers, such as two or three on each side of a stage, it's best to keep the enclosures stacked or positioned tightly together for the benefit of maximum mutual coupling.

If an external electronic crossover is employed, the use of a subwoofer will free up the low-frequency power demand of the full-range loudspeaker(s), thereby increasing output capability in the upper bass range. An electronic crossover will also reduce *intermodulation distortion* in the amplifiers, resulting in much improved sonic performance.

Note: The guidelines referred to above are "rules of thumb only." Performance will vary based on room acoustics, room geometry (particularly ceiling height), the location of the loudspeaker(s), the size and type of the amplifiers, and the stylistic demands of the music and speech that are to be reproduced.

POSITIONING SUBWOOFERS

Subwoofers are far less directional than the mid-range and high-frequency loudspeakers they are designed to augment. This is because low-frequency wavelengths are significantly longer than mid-range and high-frequency wavelengths. A 30 Hz wave is approximately 35 feet in length and a 100 Hz wave is approximately 11.3 feet in length. These extremely long wavelengths cause behavior that's quite different from their shorter mid and high-frequency counterparts.

First, long wavelengths do not 'see' small or moderate size obstructions as obstacles; they simply diffract around such barriers, as if they're not there.

Second, the substantial length of low-frequency waves can make it difficult to distinguish their source direction. This is why a single subwoofer can often be used successfully to augment a stereo pair of mid-high loudspeakers, without unduly harming the stereo separation and image.

Third, low-frequency waves tend to add together quite graciously, even if their sources are separated by considerable distances, as long as they are in phase with each other. An example of this in operation is the typical *accentuation* or *build-up* of low-frequency content that is often experienced in the middle of theatres and concert halls, generated by subwoofers placed far apart on the opposite sides of the stage.

Overall, the characteristics mentioned above imply that the location of a subwoofer is not particularly critical, and to a certain extent that is true. However, there are several factors to consider before you finalize your intended location¹. Some of these are:

- (1) A subwoofer will benefit greatly in terms of power output when it's placed adjacent to boundary surfaces. If located at the junction of three surfaces, such as on the floor or ceiling in a corner (this is called Eighth Space), a given subwoofer will produce a full 9dB more output power than if that same subwoofer is located in Free Space (such as when suspended between the middle of a floor and ceiling). If located at the junction of two surfaces (Quarter Space), the subwoofer will produce 6dB more output than if suspended in Free Space. If located on a single wall, such as the floor or ceiling, the increase is 3dB. Free Power! What could be better? See Figure 8 for additional clarification:

¹A thorough understanding of how low-frequency waves transmit in acoustical environments is very helpful when designing, installing, and optimizing sound systems. We recommend reading such books as "Fundamentals of Sound" and "Psychoacoustics" by F. Alton Everest in the "Handbook for Sound Engineers" published by Howard Sams & Co.

Figure 8: Effect of Boundary Surfaces on Power Output

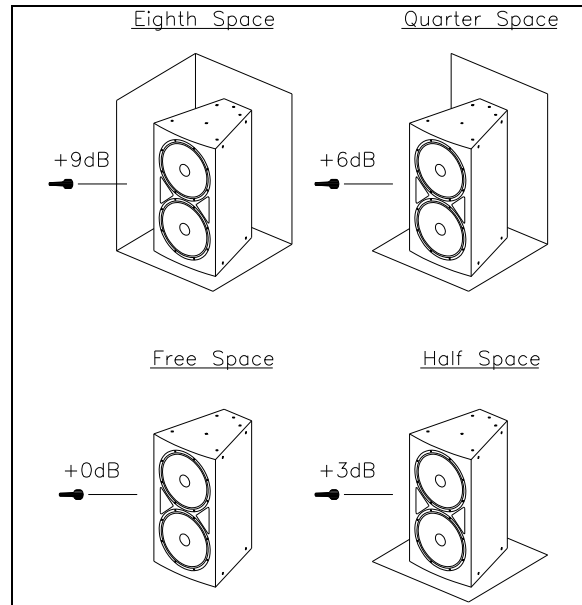

When choosing subwoofer location(s), be careful, however, not to sacrifice sonic quality for sheer power. If the available wall or corner location results in the subwoofer being located behind, or too close, to one or more open microphones, early feedback is likely to occur. If the wall or corner location is too far away from the full-range loudspeaker(s), such a location may result in the subwoofer being drastically out of time sync with one or more of the full-range speakers.

Sometimes the sound quality of a wall or corner placement is not desirable, simply due to the room's acoustical properties. Keep in mind that when wall and corner locations *are* appropriate for use, they'll provide a tremendous increase in power output, but they may not always be the best choice for sound *quality*.

- (2) Keeping the subwoofer(s) as close as possible to the mid and high loudspeaker(s) will decrease phase irregularities and *time smear*. If subwoofer(s) are placed too far away from the mid/high loudspeaker(s), the listener will experience a disjointed character to the program material, causing the musicality of the system to suffer.
- (3) Although subwoofers are not particularly directional, still their acoustical output follows the inverse square law. That is, every time the distance from the subwoofer to the listener is doubled, the output level will decrease by 6dB. When covering a large space with multiple subwoofers, it may be of benefit to space them some distance apart from one another to even out the levels throughout the space. Typically, this would only be done if the mid/high loudspeakers are also spaced apart from one another, such as in a distributed system in a sports venue. Although this will help maintain an even level throughout the listening space, there may be some areas that lie between two or more subwoofers that experience a certain amount of power subtraction caused by *destructive interference*. Destructive interference occurs when waveforms meet and are partially or wholly out of phase with each other, due to unequal path lengths.

Conversely, if multiple subwoofers are located directly adjacent to one another, their power output will add together almost seamlessly. This is known as *constructive acoustic addition*. However, this may produce an undesirable hot-spot of low-frequency energy that might possibly be too close to a seating area.

It's always a good idea to experiment with trial locations before finalizing your installation plan. Even a very experienced sound system designer cannot predict the precise effect that one location may have over that of another, if he/she is not intimately familiar with the room acoustics. When planning loudspeaker locations, it's wise to discuss the matter with someone who may have prior experience operating sound systems in that particular room, such as the resident mixing engineer.

POLARITY

Unless the full-range loudspeaker(s) are stacked directly on top of the subwoofer(s) with cone drivers physically aligned with the subwoofer cone drivers, it's likely that the phase relationship of the two systems may not be optimal. This can be tested by reversing the polarity of one system relative to the other, as described below.

First, however, it's important to understand that the correct polarity of the full-range system relative to the subwoofer is a function of their physical placement in relation to one another. This is known as the Phase Relationship of the two systems, though Absolute Polarity plays a role as well, which will be discussed later.

Depending on the placement of the subwoofer in relation to the full-range loudspeaker(s), as well as the selected crossover point, the optimal response of the system might be obtained by reversing the polarity of the full-range loudspeaker(s). The easiest way to determine the proper polarity is to excite the system with a test signal (such as pink noise) and to view the resultant response on an audio spectrum analyzer. If such equipment is not available, it is also possible to determine the best polarity relationship by careful listening.

One orientation of polarity, either normal or reversed, should result in a discernable dip through the crossover region due to acoustic cancellation. The opposite polarity should result in either a flat response or a peak through the crossover region, due to acoustic addition.

Note: When experimenting to determine the proper polarity, you can reverse the full-range loudspeaker(s) or the subwoofer, but never both at the same time (reversing both at the same time will not alter the phase relationship of the two systems). If there is one subwoofer and several full-range enclosures in the same system, it will, of course, be easier to reverse the subwoofer's polarity to test the response. Ultimately, as we'll see below, it's best to keep the subwoofer in a polarity-positive state.

If there is no discernable difference, or only a very minimal difference in the measured or audible response when the polarity is reversed, it indicates one of two things:

- (1) The full-range system that the subwoofer is being used with does not reproduce enough low-frequency output to cause either cancellation or addition with the subwoofer. This would be true if the full-range system is made up of very small loudspeakers, like those that are used for front-fill and underbalcony fill.
- (2) The placement of the subwoofer in relation to the full-range loudspeaker is not optimum. Little or no response variation will occur if the physical relationship results in an approximate $\frac{1}{4}$ wavelength of offset at the center of the crossover frequency.

The solution to (1) is for both systems to remain in positive polarity. No inherent harm will occur if the full-range system simply does not reproduce enough low-frequency energy to either add to, or cancel, the subwoofer's output - though the use of a high-pass filter or external crossover is always recommended to avoid sending low frequency energy to any small full-range loudspeaker, in order to keep it from being damaged by trying to reproduce frequencies that are below its intended operating range.

The solution to (2) is to either change the physical relationship of the two systems, or to delay one of the two systems (whichever one is positioned closer to the listener) with a digital delay. A high-quality, high resolution measurement system that can read and depict phase response or impulse response would be very useful in this situation. However, without such a system, you can determine an effective delay time by trial and error. Simply increment the delay time in small steps (1 ms or less), until the action of reversing the polarity produces maximum cancellation in one orientation and maximum addition in the opposite. By using a digital delay, you will have preserved the phase and impulse response of the system, and you can now filter out any objectionable mid-bass overlap with an equalizer.

If a delay is not available, it is recommended that either the subwoofer or the full-range loudspeaker be relocated closer together, so that reversing the polarity of either the subwoofer or the full-range loudspeaker (but again, not both at once!) will result in a distinct dip or peak at crossover as discussed above.

If this cannot be done due to physical restrictions, the subwoofer and the full-range loudspeaker should be moved further apart until there is a distinct dip at the crossover frequency in one position of polarity. It will take some trial and error to determine the optimal physical relationships.



TIP: *It's a good idea to experiment with different loudspeaker locations by conducting listening tests before you finalize the locations (this is especially important in permanent installations). Make sure to use live microphones and live instruments (if applicable), as well as track playback. Choosing the physical location of the loudspeakers in the room is **always** the most important part of any successful system installation.*

Further notes on polarity: In some acoustical environments, the system may sound better when the polarity relationship is technically non-optimal, resulting in a dip or attenuation at crossover, compared to optimal polarity where the crossover region is *accentuated* by the overlap of the subwoofer and the full-range speaker(s). However, this is not the best way to achieve the sound quality that you're seeking. The proper course of action is to establish relative polarity that accentuates the overlap that's causing the peak at crossover, and then equalize (EQ) the peak with a parametric equalizer until the response is flat, or until you've achieved the tonal response you desire (we'll explain why below).

Alternatively, you might insert a high-pass filter in the full-range system (typically at 80 – 100 Hz with a 12dB/octave slope), so that the overlap with the subwoofer is reduced in magnitude.

A third technique is to increase the slope of the crossover to 24 dB per octave or 48 dB per octave, if the crossover has such capability, thereby reducing the bandwidth of the spectrum in which the two sources overlap.

There's an important reason for taking one or more of the measures discussed above. If that nice-sounding response dip at crossover is in fact due to phase cancellation, it means that the drivers and amplifiers will be working harder than they should to produce less sound pressure level than they are capable of, due to the acoustic cancellation taking place. All that cancelled energy uses power unnecessarily!

Instead of putting the two systems out-of-phase to get the sound you want, if you attenuate the peak at crossover with any of the methods described above², you are *reducing* the power that's required to obtain a given sound pressure level. This will result in more available power, more headroom and less demand on the drivers and amplifiers, thereby lowering the potential for distortion and damage under high power conditions.

Now that you've chosen the final physical locations for your full-range loudspeakers and subwoofers, established their optimum phase relationship, and brilliantly EQ'd any crossover peaks, you're almost ready to permanently wire the system. But first read the section below on "Choosing Appropriate Loudspeaker Models and Appropriate Signal Processors."

CHOOSING APPROPRIATE LOUDSPEAKER MODELS AND APPROPRIATE SIGNAL PROCESSORS

In order to design, install, and operate a highly successful sound system, the initial product selection must be carefully considered. Loudspeakers, amplifiers, and processing electronics must be appropriately scaled to handle the job that will be required of them.

- Choose VERIS 2 models with high enough maximum power to provide the needed SPL at the farthest listener - with attention paid to maintaining appropriate headroom. Typical headroom factors are at least 6 dB for voice paging, at least 10 dB for voice reinforcement, and as much as 20 dB for music reinforcement.
- Select VERIS 2 models with the right frequency response for the application. Voice-only systems do not need extended low frequency response, but music systems usually do (depending on the style of music). Acoustic guitars do not require the same LF response as dance music.

Subwoofers will improve the sound quality of a music reinforcement system, but may reduce intelligibility in a voice-only system in a reverberant space.

²The three corrective methods referred to; i.e. **equalizing, high-passing, and increasing the slope of the crossover**, are all various implementations of equalization.

- VERIS 2 models should be chosen with the best dispersion patterns to cover the audience evenly. Each loudspeaker should be carefully focused towards the listeners while being careful to keep acoustic energy away from walls, ceilings, and other reflective surfaces, including physical obstructions that are caused by architectural elements (such as columns) or furnishings.
- In many cases, locating all the main loudspeakers in a central location will simplify the installation, mechanically and electrically, while also improving acoustical performance. This is typically referred to as a center cluster design. Centralized clusters tend to create very coherent sound sources because all the energy is emanating from a single location. However, not all applications and venues are suitable for central clusters. In some cases it's more effective to distribute the loudspeakers throughout the venue, to maintain a more even distribution of SPL. The factors that drive the optimal design decisions can be simple or quite complex, and include such elements as ceiling height, room reflectivity, size of the venue, location of live sound sources (if any), distance between distributed loudspeakers, and much more.

Our TAG Team (Technical Applications Group) stands ready to help! We'll gladly discuss your application and provide expert advice. Please feel free to call or email us at any time.

RECAPING: After determining the loudspeaker complement and positioning, it's important to select power amplifiers that are large enough to achieve the required SPL with enough headroom to avoid clipping. The use of a limiter to protect the loudspeakers from excessive energy is very important, as is the use of external high-pass filters. Proper wiring design is also essential, and gain adjustment is important to achieve the best signal-to-noise ratio.

dSPEC226 – THE SIMPLE AND EFFECTIVE ANSWER

Community's **dSPEC226** loudspeaker processor solves many installation issues in moments, where using other signal processors might take hours... or even days.

dSPEC226 is a full-featured, multi I/O DSP loudspeaker management system that was designed to be the optimal companion to any Community loudspeaker system. In particular, each dSPEC unit contains a library of presets created at the factory intended to optimize the performance of each model of Community loudspeaker. By simply adding the various model(s) of loudspeaker(s) that are in your installation from a drop-down menu, you're already more than "half-the-way there." dSPEC then offers delay and extensive equalization capability to optimize the system for the room it's installed in.

dSPEC226 also provides extensive electronic protection algorithms (three levels of protective limiters), that at the push of a button, adjusts protection thresholds and other parameters to each amplifier and speaker in the system.

Remote control of user-presets is also possible, along with a host of other features – far too many to describe in full, in this Manual. Please call us or visit our website to see how **dSPEC226** can make your job far easier – with a far better outcome – than using a generic loudspeaker processor.

COMMISSIONING THE SYSTEM

Commissioning is the process of optimizing the performance of the system after it has been installed. There are several steps in commissioning. First is verifying the proper operation of every system component, and then adjusting system gains and levels.

The last step in system commissioning is known as system equalization or "voicing." Equalization is the process of adjusting the frequency response of the system to optimize voice intelligibility or musical sound quality (or both). Note that VERIS 2 loudspeakers are factory voiced to optimize their speech intelligibility and musical sound quality. For this reason, many designers find they can minimize overall system equalization and still achieve excellent voice intelligibility and musical sound quality without extensive EQ. However, in the end this is a function of the room acoustics. A large, highly reverberant room will require more attention than a small, dry acoustic space.

When equalizing a VERIS 2 loudspeaker system the following points should be kept in mind to achieve the best results and to avoid damaging the drivers.

1. Use only small amounts of equalization. In particular, do not boost frequencies by more than about 3 dB. Cutting frequencies by more than 3 dB of attenuation is acceptable, but bear in mind that extreme frequency cuts will usually result in less than optimum performance, unless carefully derived by use of a precision measurement system in a room that has excessive resonance. **Rule of Thumb: less is usually more.**

2. Do not attempt to boost any frequencies below 100 Hz with a graphic equalizer. Note that with the recommended high-pass filter, moderate amounts of boost from a simple bass control are acceptable.

FOR MORE INFORMATION AND APPLICATION ASSISTANCE

For more information on installing and operating your VERIS loudspeaker, please refer to Community's web site at www.communitypro.com. For application support, service or warranty information, refer to Community's web site or contact Community at 610-876-3400 or toll-free at 800-523-4934.

RIGGING / SUSPENSION AND SAFETY

TERMINOLOGY: The terms "rigging", "flying" and "suspension" are often used interchangeably to describe the installation of loudspeaker systems above ground level. None of these terms pertain to, or attempt to describe, the actual method that is used (cables, brackets, chains, etc., etc.).



DANGER: The loudspeakers described in this manual are designed and intended to be suspended using a variety of rigging hardware, means, and methods. It is essential that all installation work involving the suspension of these loudspeaker products be performed by competent, knowledgeable persons who understand safe rigging practices. Severe injury and/or loss of life may occur if these products are improperly suspended.



DANGER: All rigging fittings and inserts must remain sealed with the included flat-head Allen screws or they must be fitted with properly rated optional mounting hardware. Any missing fasteners will compromise the structural integrity of the enclosure and constitute a safety hazard. Do not suspend this loudspeaker unless all fasteners are securely in place!

COMMUNITY RIGGING HARDWARE WARRANTY: Community warrants that its loudspeaker systems and its optional mounting and rigging hardware have been carefully designed and tested. Community loudspeakers may be safely suspended when each loudspeaker model is suspended with Community-manufactured optional mounting and rigging brackets specifically designed for use with that particular model of loudspeaker. This warranty applies only for use under normal environmental conditions, and when all loudspeakers, component parts, brackets and hardware are assembled and installed in strict accordance with Community's installation guidelines contained herein. Beyond this, Community assumes no further or extended responsibility or liability, in any way or by any means whatsoever. It is the responsibility of the installer to insure that safe installation practices are followed, and that such practices are in accordance with any and all local, state, federal, or other, codes, conditions, and regulations that may apply to, or govern the practice of, rigging, mounting, and construction work in the relevant geographic territory. Any modifications made to any parts or materials manufactured or supplied by Community shall immediately void all pledges of warranty or surety, related in any way to the safe use of those parts and materials.



WARNING - NON-COMMUNITY RIGGING HARDWARE: Non-Community hardware used for rigging a VERIS 2 loudspeaker must be certified by the supplier for such use and must be properly rated for safety.

IMPORTANT NOTES ON RIGGING LOUDSPEAKERS

There are three areas of responsibility for rigging loudspeakers. The first is the building structure. Always consult with the building architect or structural engineer to assure the ability of the structure to support the loudspeaker system. The second area of responsibility is the loudspeaker itself. Community certifies its loudspeaker systems and rigging accessories for suspension when they are properly installed according to our published guidelines. The third area of responsibility is everything between the loudspeaker and the building structure and the actual process of installation. The installing contractor assumes this responsibility. Loudspeaker rigging should be performed only by certified rigging professionals using certified rigging hardware chosen for the specific application. Prior to installation, the contractor should present a rigging plan, with drawing and detailed parts list, to a licensed structural engineer (P.E.) or architect for written approval.

VERIS 2 MOUNTING BRACKETS AND ACCESSORIES

Below are descriptions of mounting brackets, suspension kits and other accessories manufactured by Community for use with VERIS 2 loudspeakers. In this section the terms "suspension" and "fly" mean the same thing: to elevate the loudspeaker enclosure above the ground surface. Consult the user's guide included with each part for detailed safety instructions. It is the responsibility of the installer to insure that safe installation practices are followed. Installation of loudspeakers should only be performed by trained and qualified personnel. It is strongly recommended that a licensed and certified professional structural engineer approve the mounting design.



IMPORTANT: All rigging fittings must remain sealed with the original fasteners, or with added rigging fasteners. Otherwise air leaks will occur in the enclosure that can compromise the low-frequency performance with distortion, reduced output, and possible driver damage.



WARNING: VERIS 2 rigging fittings are rated at a Working Load Limit of 100 lbs (45.4kg) with a 10:1 safety margin. No single rigging fitting should ever be subjected to a load that is greater than 100 lbs. Failure to heed this warning could result in injury or death!



VERIS Handle & Stand Socket **Model V-HSS**

The V-HSS accessory for VERIS 2 models 6/26/8/28 attaches to the loudspeaker enclosure's rear M6 threaded fittings to create a stand socket mount and convenient carrying handle. It is formed of zinc plated black powder coated steel. Perfect for A/V professionals.



Seat Track Kit **Model STKIT**

A Seat Track Kit is available that fits all models of VERIS 2 full-range loudspeakers. The STKIT provides a safe and convenient means of suspending a single enclosure. By purchasing multiple kits, one enclosure may be safely suspended over another.



Ceiling Mount Kit **Model CMKIT**

The Ceiling Mount Kit creates a hang point from a ceiling surface. The CMKIT consists of a ceiling mount bracket and a bolt that fastens to a U-yoke bracket or to one of several optional loudspeaker brackets. It can be used with all full-range VERIS 2 loudspeakers. Note: The yoke is sold separately for VERIS 2 models 12/15/32/35. The yoke is included with VERIS 2 models 6/26/8/28.



Vertical Flying Kit **Model VFKIT**

The VFKIT for V2-12/15/32/35 full-range loudspeakers allows two same-size enclosures to be flown at 45 and 60 degree splay angles. To vertically array 3 same-size enclosures, use 2 VFKIT's. To vertically array 4 same-size enclosures, use 3 VFKIT's. Four eyebolts are included with each VFKIT.



Yoke Brackets

Models VB-Y12, VB-Y15, VB-Y32, VB-Y35

Optional yoke brackets for the larger full-range models VERIS 2 12/15/32/35 allow for direct horizontal mounting of the loudspeaker to a wall or ceiling. This unique yoke bracket also permits vertical mounting with a selection of 0°, 10°, or 20°, of either upward or downward inclination.

Note: Yoke brackets are included with compact VERIS 2 models V2-6/8/26/28. Refer to the supplementary instruction sheet included with these models for more information and installation instructions.



Versatilt Bracket

Model VB-VST

The VB-VST allows for precise installation of a single full-range VERIS 2 loudspeaker from the ceiling. It includes a rotational device, a hang bracket that fastens to the top or bottom of the enclosure, and a ceiling mount bracket. It is designed to be used with any 12" or 15" two-way or three-way full-range VERIS 2 loudspeaker. An M10 eyebolt is included for use as a safety point.



Tilting Bracket

Model VB-TILT

The TILT bracket allows for precise angling of a VERIS 2 loudspeaker. The VB-TILT is a two-part rotational device that can be used to fasten one enclosure to another; to fasten an enclosure to the CMKIT Ceiling Mount Kit; to fasten to a yoke bracket permitting one loudspeaker to be angled in relation to another in two axes. The VB-TILT can be used with all full-range VERIS 2 enclosures. Note: Yokes are sold separately for VERIS 2 models V2-12/15/32/35. A yoke is included with all VERIS 2 models V2-6/26/8/28.



Eyebolt Kit

Model Nos. M10EYBLTKIT, M6EYBLTKIT

Suspend your VERIS 2 loudspeakers safely and easily. Use the 10mm M10EYBLTKIT with V2-12/15/32/35; use the 6mm M6EYBLTKIT with the smaller V2-6/8/26/28. Four eyebolts are included in each kit.



Vertical Yoke Kits

Model Nos. VB-VY6/VY8/VY26/VY28/VY12/ VY15/VY32/VY35, VYC, FB27/35/50, FBHK

The Vertical Yoke Kit allows for precise installation of a single full-range VERIS 2 loudspeaker from an over-head yoke. Also available are the VERIS 2 FLY-BAR accessories for even more versatile flown configuration options using multiple VERIS 2 loudspeakers.

TROUBLESHOOTING GUIDE

Should you have a problem with your VERIS 2 loudspeaker(s), find the symptom and follow the associated **WHAT TO DO** instructions below. Please note that a particular symptom may have several possible causes.

SYMPTOM	PROBABLE CAUSE	WHAT TO DO
High distortion, low output, or no output from any or all drivers.	Faulty connection to the loudspeaker. Possible solder joint failure on crossover card.	Using an ohmmeter, check the continuity of the wiring to the loudspeaker. If the wiring is OK, remove the input panel and check all solder joints on the crossover and the wiring to the drivers. Visually inspect solder joints as cold joints may only malfunction under high current. Repair as needed.
Distortion from the loudspeaker at higher volume levels.	Too little amplifier power.	If the power rating of the amplifier is too low, it will clip at higher volume levels. Reduce the volume level or use a more powerful amplifier.
Distortion from the loudspeaker at moderate to high volume levels.	Driver is malfunctioning.	Using a sine wave oscillator or wide range program at moderate levels, listen to each driver to isolate the problem. Replace as needed.
Low or no output from the low-frequency driver.	Low-frequency driver, crossover, or amplifier is malfunctioning.	Test and replace as needed.
Low or no output from the low-frequency driver.	Mis-wired NL4 -compatible locking connector.	Check wiring and correct as needed.
Low or no output from the mid-frequency driver (applies to three-way systems only).	Mid-frequency driver, crossover, or amplifier is malfunctioning.	Test and replace as needed.
Low or no output from the high-frequency driver.	High-frequency driver, crossover, or amplifier is malfunctioning.	Test and replace as needed.
Low volume level.	System gain is too low.	Check to make sure that the audio signal to the amplifier is high enough to drive it properly. Check all volume/level controls and gain switches in the system including the amplifier input attenuator.
Low volume level.	Signal or speaker wire connection is shorted.	Make sure the signal and input wire connections inside all system connectors are not shorted or open. Even one small wire strand shorting the +/- signal terminals together anywhere in the system can cause this problem.
No sound.	Amplifier is not on or loudspeaker is disconnected.	Check that amplifier is turned on and that loudspeaker is properly connected to the amplifier.
No sound or very low volume.	No audio signal.	Check that all the audio equipment in the signal chain is powered on and that all gain controls are in the proper position.
Noises from the loudspeaker (buzzes or rattles).	Grille or hardware is loose.	Make sure the front grille screws are securely seated and that any external mounting hardware is tightened or secured from vibrating.
Noises from the loudspeaker (buzzes or rattles).	Driver is malfunctioning.	Using a sine wave oscillator or wide range program at moderate levels, listen to each driver to isolate the problem. Replace as needed.
Sound cuts in and out at high levels.	The crossover protection circuits have been activated.	This usually means that the loudspeaker is being constantly overdriven and the crossover protection circuits are reducing the power to the loudspeaker as a protective measure. Reduce the volume level to the loudspeaker.
Sound cuts in and out.	Bad connection.	Check all connections and cabling for shorts or loose connections. Even one small wire strand shorting the +/- signal terminals anywhere in the system can cause this problem.
Sudden 6 dB loss in sound level.	The crossover protection circuits have been activated.	This usually means that the loudspeaker is being constantly overdriven and the crossover protection circuits are reducing the power to the loudspeaker as a protective measure. Reduce the volume level to the loudspeaker, to restore full dynamic range.

SERVICING VERIS 2 LOUDSPEAKERS

Any driver service required can be accomplished from the front of the enclosure by removing the screws around the edge of the grille. Crossovers and connections may be accessed by removing the rear connector plate. For warranty repair, contact Community directly or ask us for the location of your nearest Authorized Service Center.

TECHNICAL DRAWINGS

V2-6

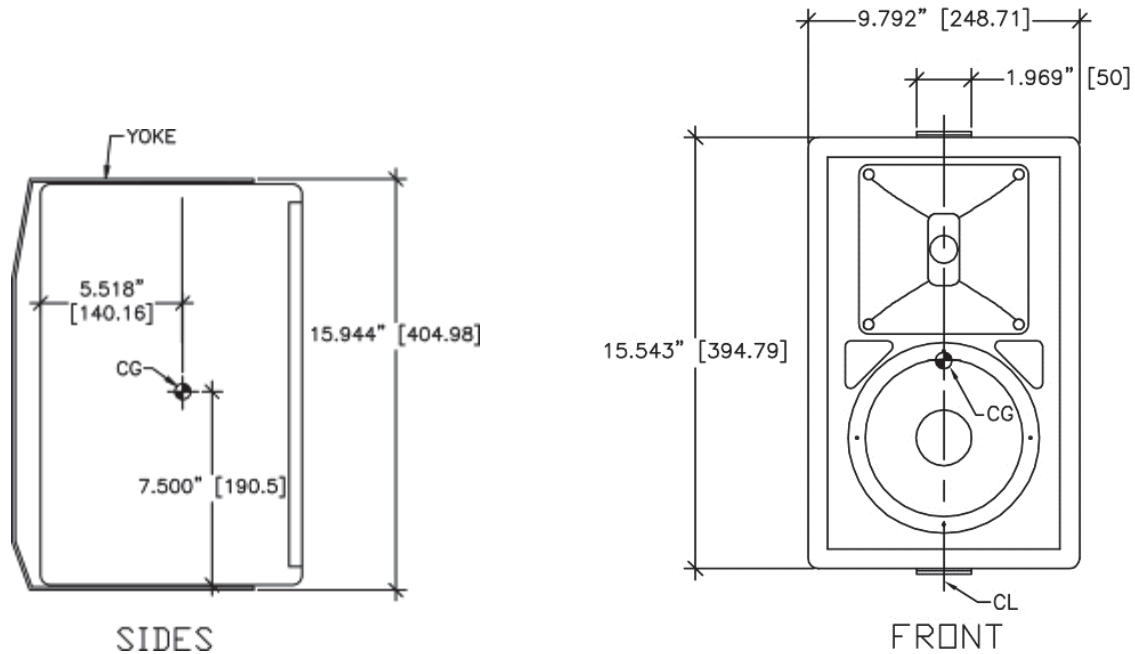
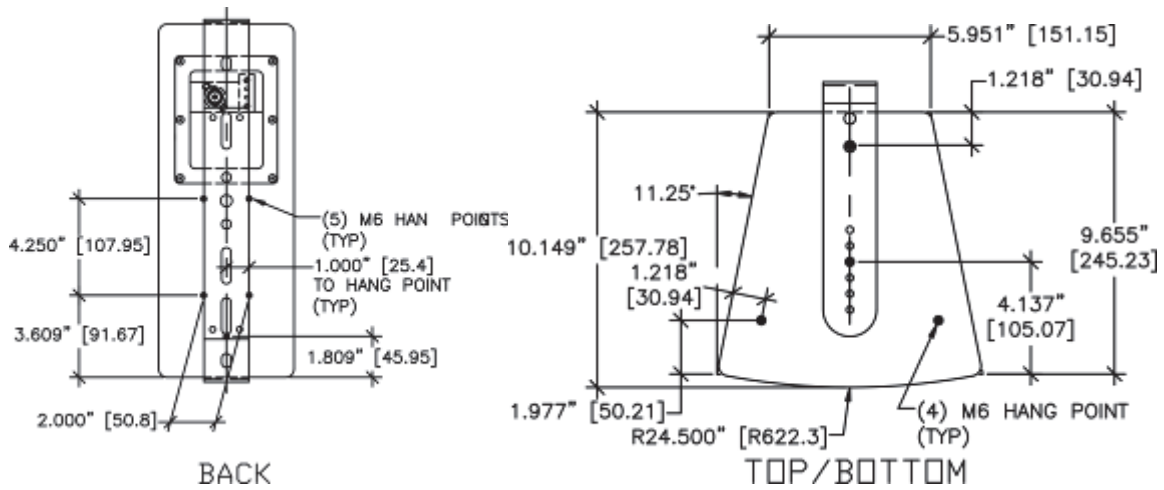

V2-6 Notes:

The V2-6 has 9 x M6 hang points plus 4 x M6 rear mounting points for third-party 30 lb. mounting devices. The rear mounting points also accept the V-HSS handle and stand socket accessory. A steel yoke bracket allowing 0°, 10° and 20° angles is included. For yoke mounting instructions, refer to the supplementary instruction sheet included with this model.

V2-8

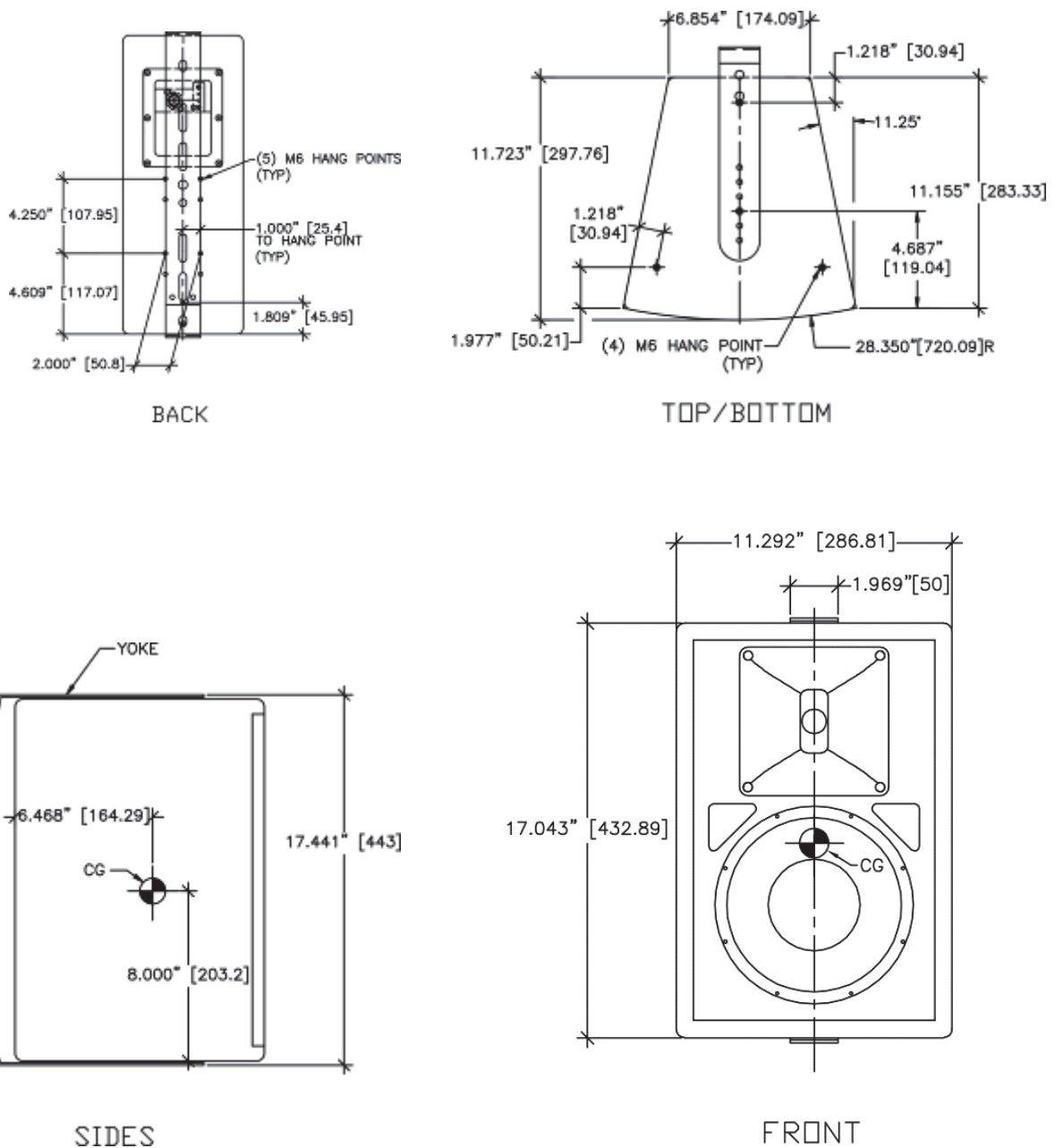

V2-8 Notes:

The V2-8 has 9 x M6 hang points plus 4 x M6 rear mounting points for third-party 30 lb. mounting devices. The rear mounting points also accept the V-HSS handle and stand socket accessory. A steel yoke bracket allowing 0°, 10° and 20° angles is included. For yoke mounting instructions, refer to the supplementary instruction sheet included with this model.

V2-26

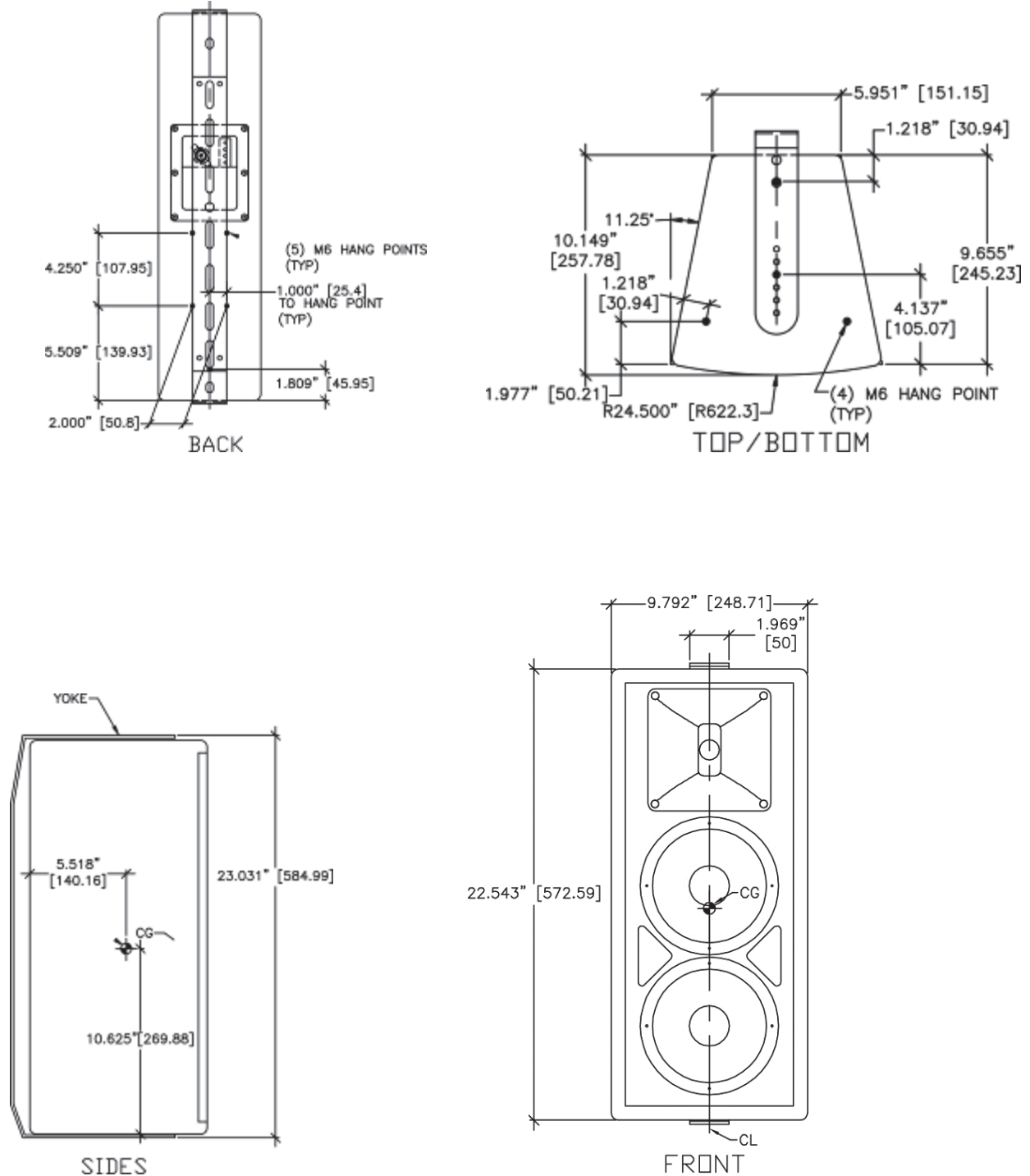

V2-26 Notes:

The V2-26 has 9 x M6 hang points plus 4 x M6 rear mounting points for third-party 30 lb. mounting devices. The rear mounting points also accept the V-HSS handle and stand socket accessory. A steel yoke bracket allowing 0°, 10° and 20° angles is included. For yoke mounting instructions, refer to the supplementary instruction sheet included with this model.

V2-28

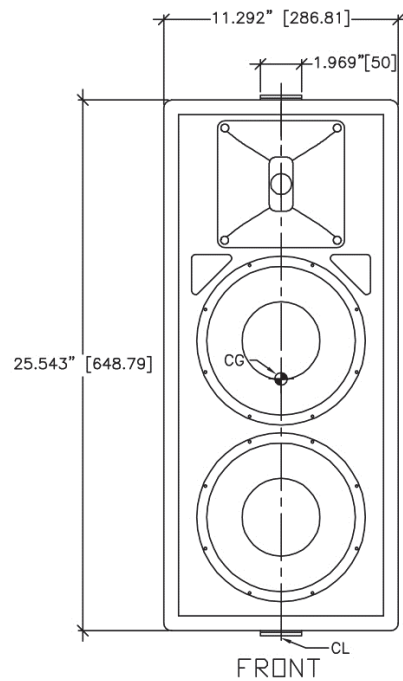
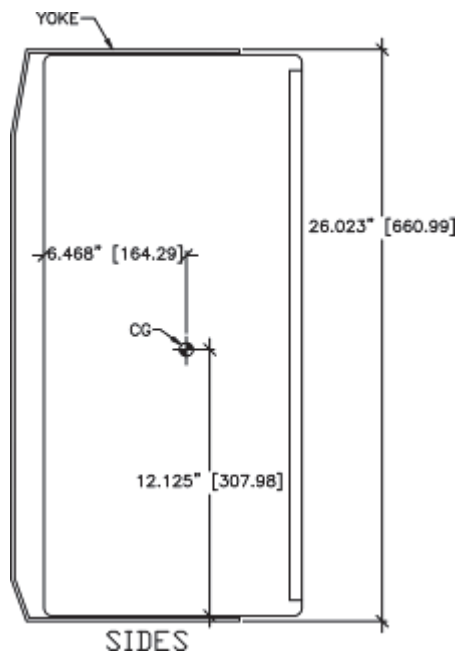
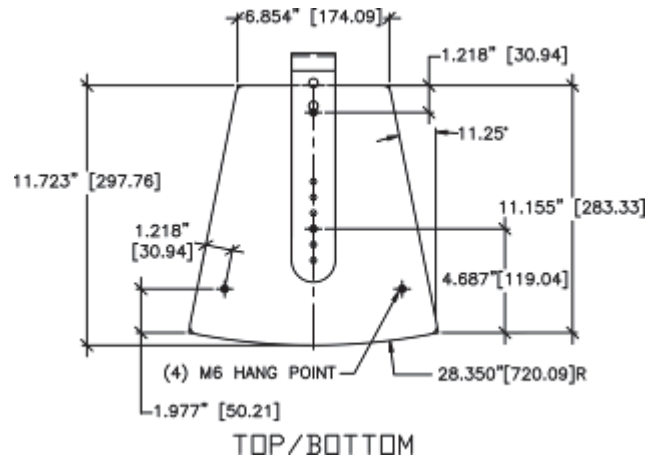
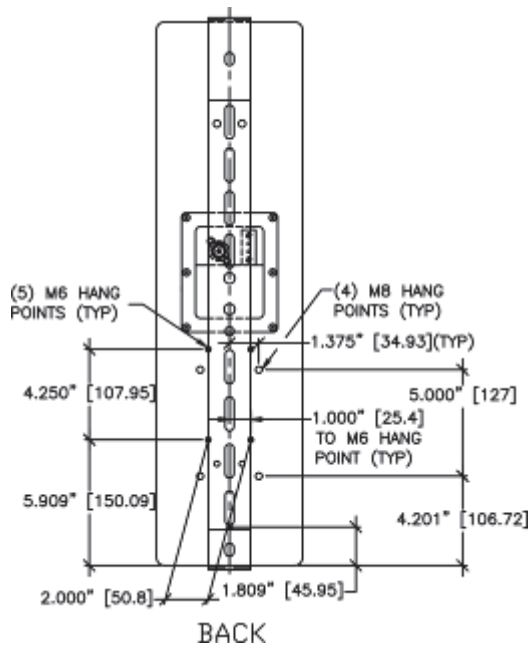

V2-28 Notes:

The V2-28 has 9 x M6 hang points, 4 x M6 rear mounting points to accept the V-HSS handle and stand socket accessory, plus 4 x M8 rear mounting points for third-party 60 lb. mounting devices. A steel yoke bracket allowing 0°, 10° and 20° angles is included. For yoke mounting instructions, refer to the supplementary instruction sheet included with this model.

V2-12

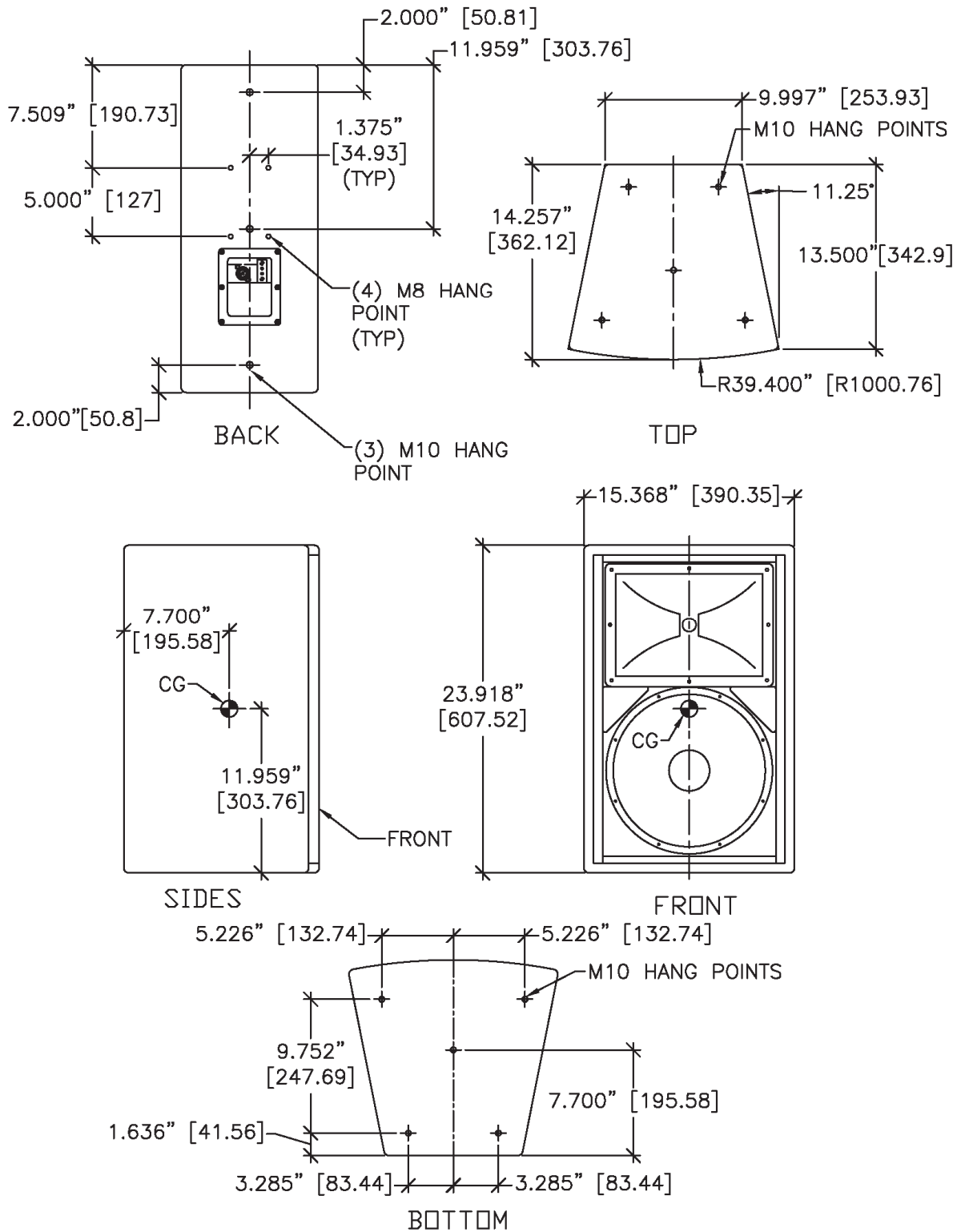

V2-12 Notes:

The V2-12 has a total of 13 x M10 hang points plus 4 x M8 rear mounting points for third-party 60 lb. mounting devices.

V2-15

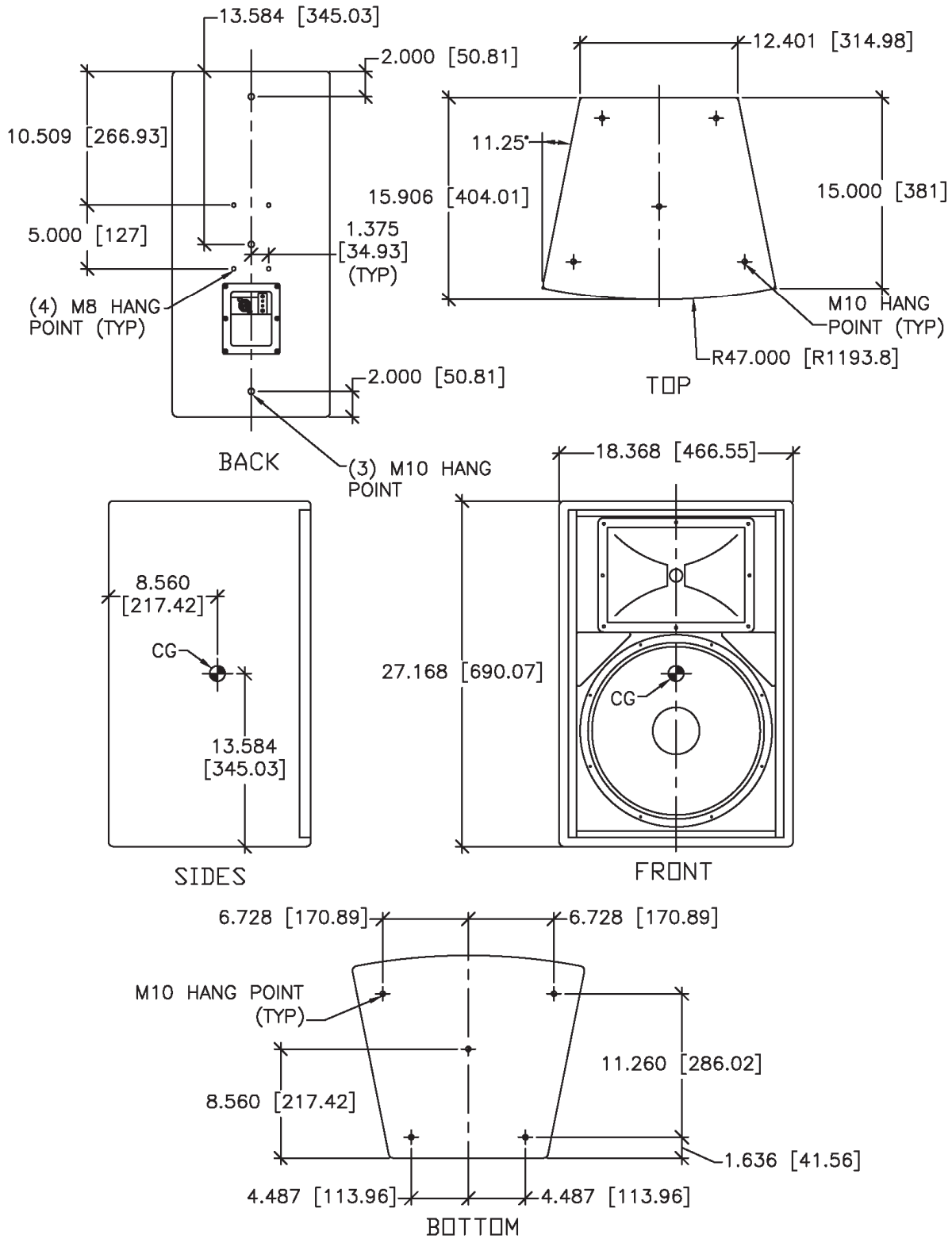

V2-15 Notes:

The V2-15 has a total of 13 x M10 hang points plus 4 x M8 rear mounting points for third-party 60 lb. mounting devices.

V2-32

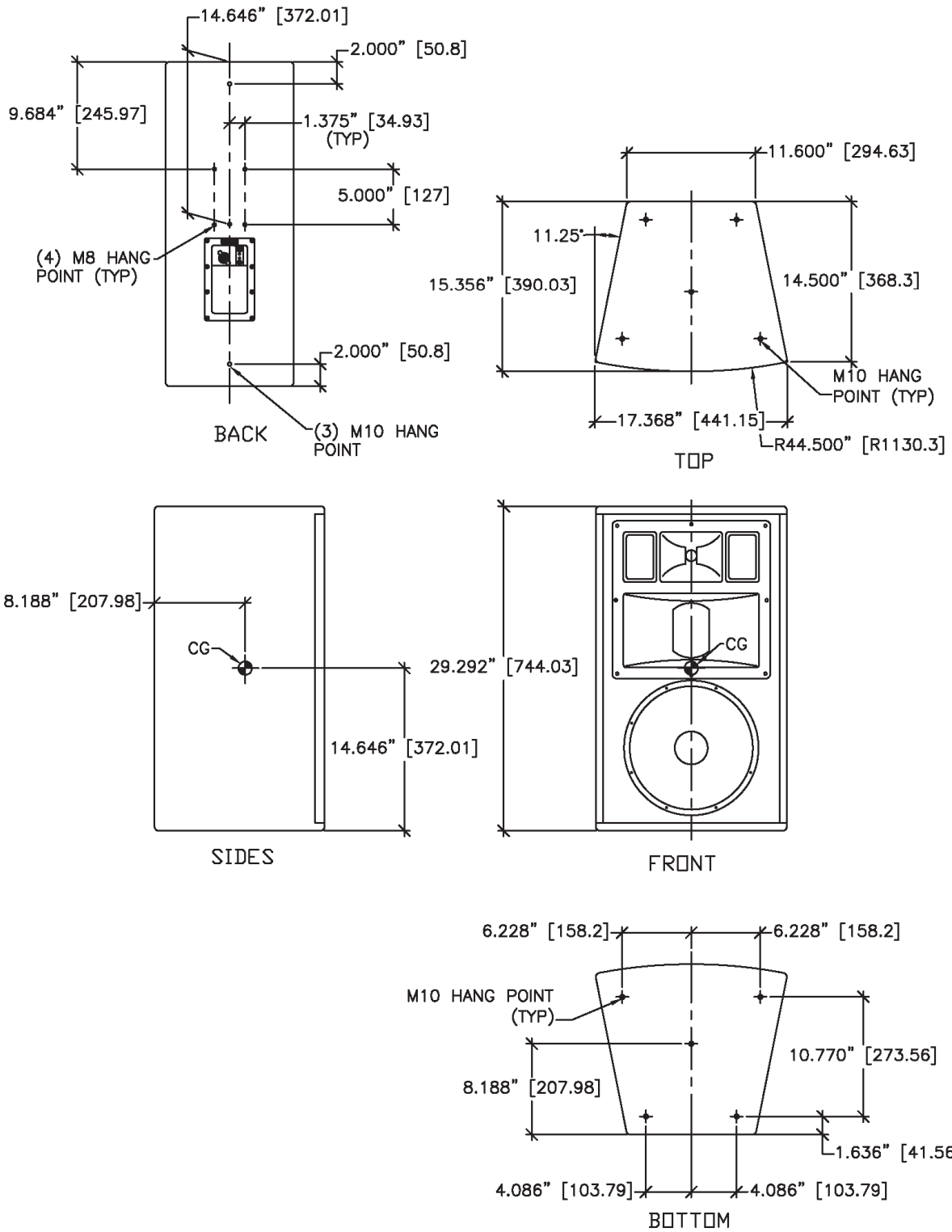

V2-32 Notes:

The V2-32 has a total of 13 x M10 hang points plus 4 x M8 rear mounting points for third party 60 lb. mounting devices.

V2-35

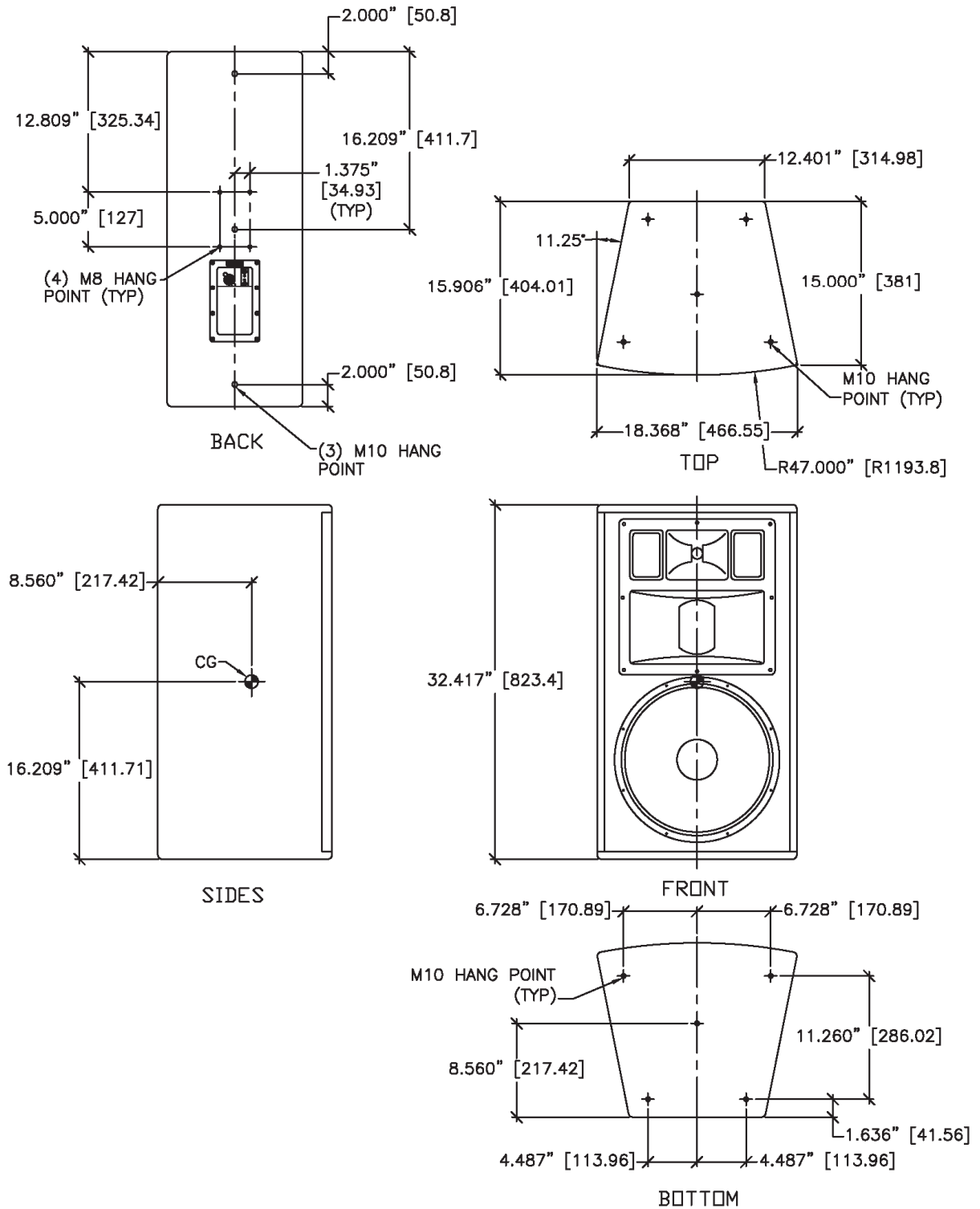

V2-35 Notes:

The V2-35 has a total of 13 x M10 hang points plus 4 x M8 rear mounting points for third-party 60 lb. mounting devices.

V2-210S

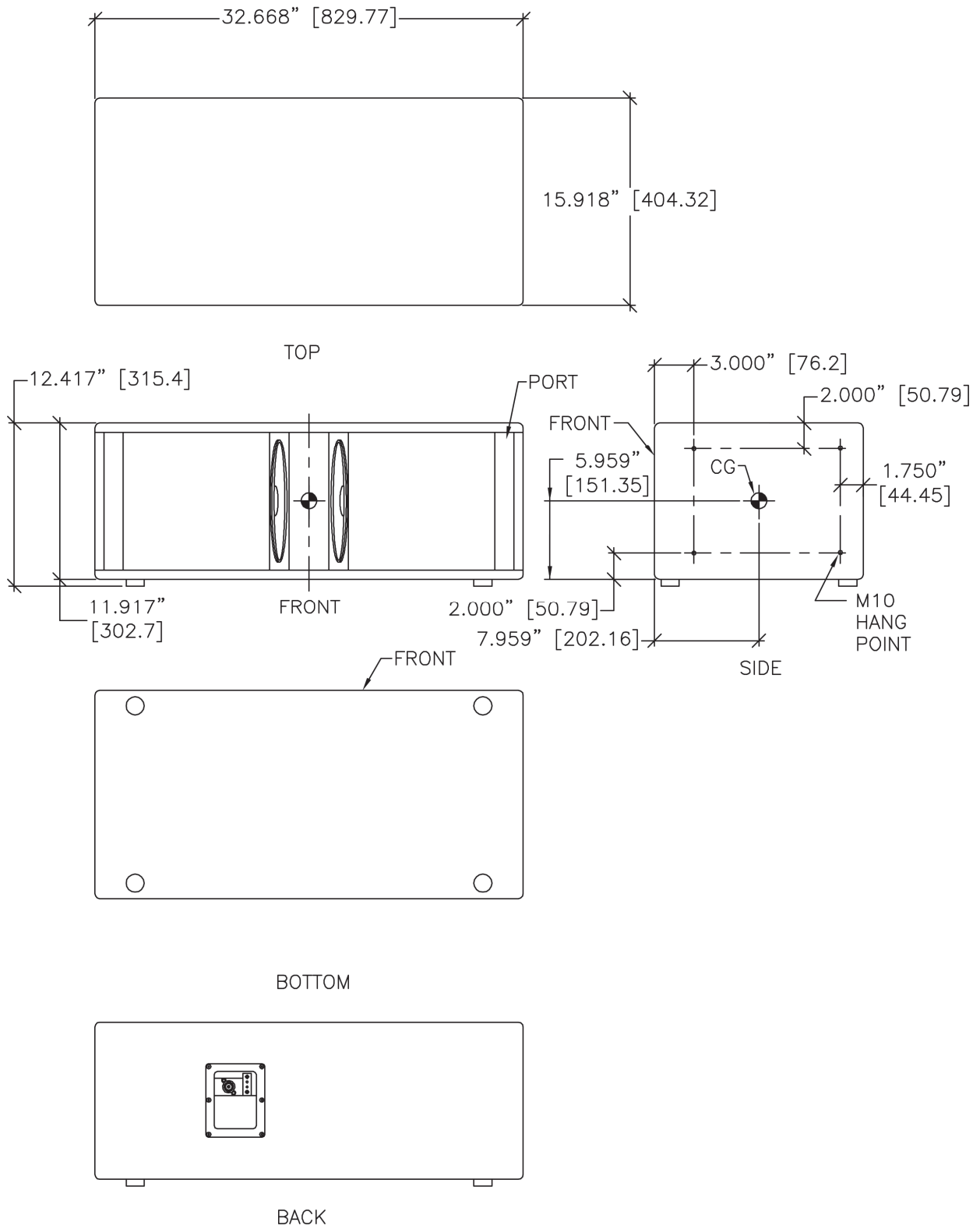

V2-210S Notes:

The V2-210S subwoofer has a total of 8 x M10 hang points, 4 on each side.

V2-212S

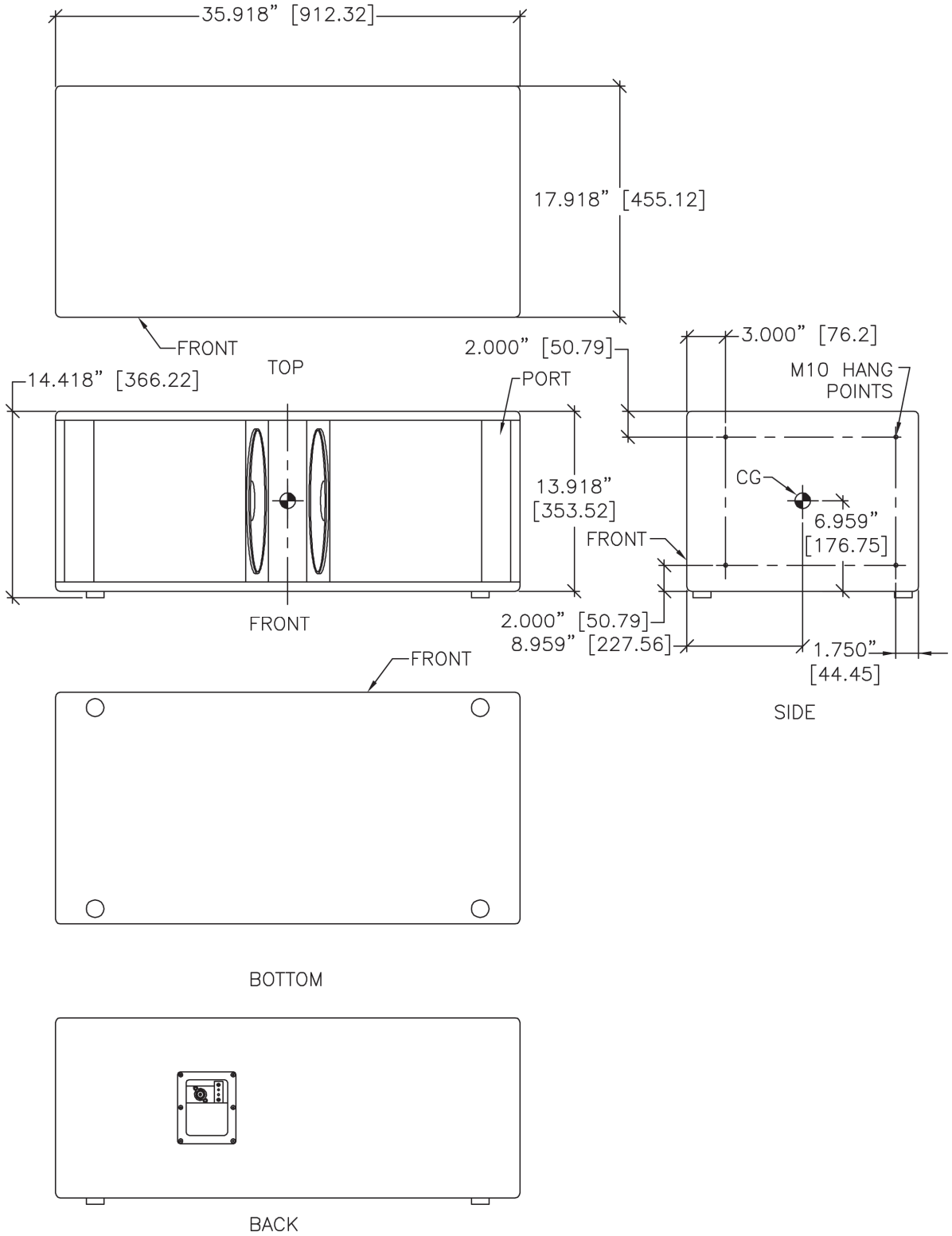

2-212S Notes:

The V2-212S subwoofer has a total of 8 x M10 hang points, 4 on each side.

V2-215S

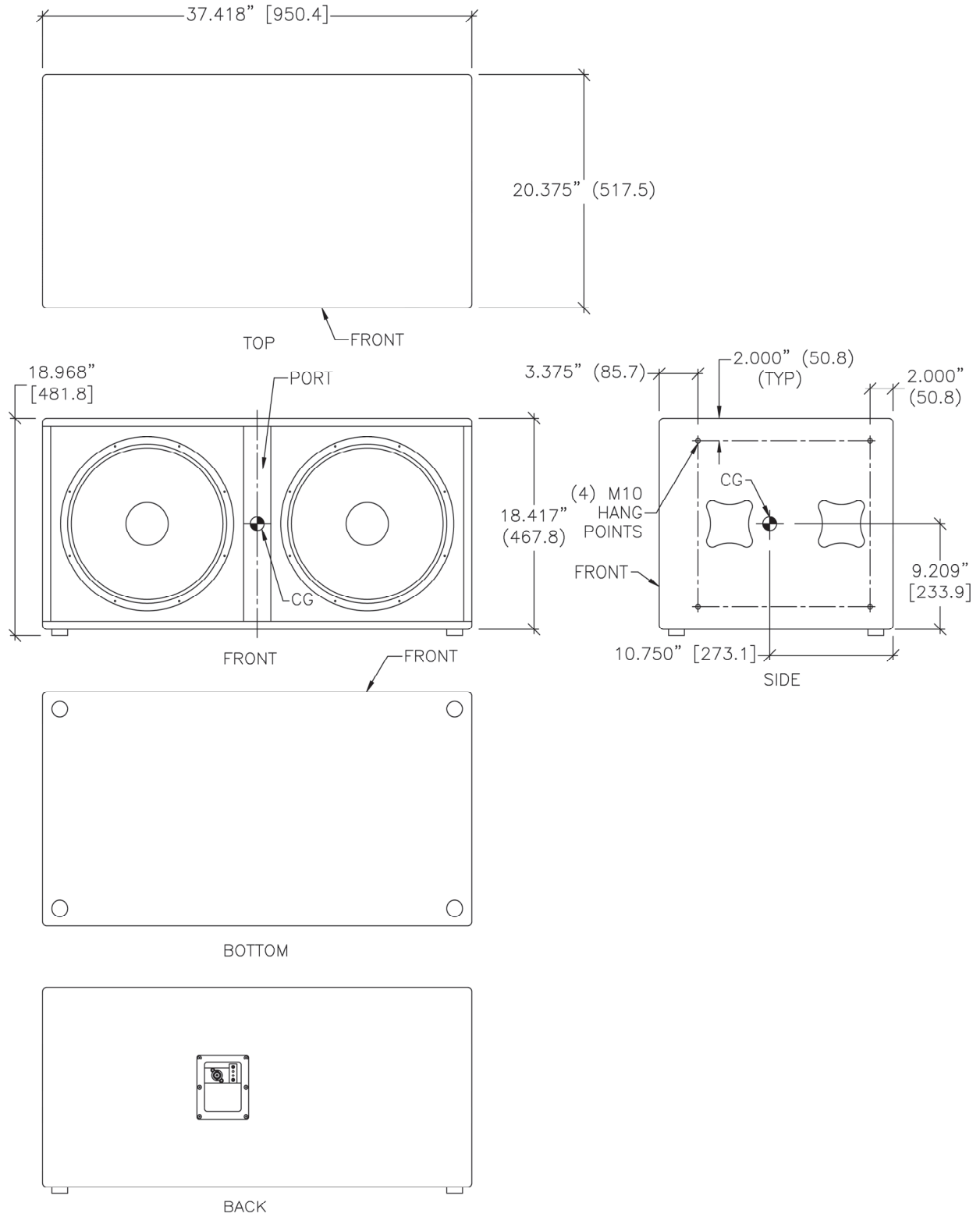

V2-215S Notes:

The V2-215S subwoofer has a total of 8 x M10 hang points, 4 on each side.



Community Professional Loudspeakers
333 East Fifth Street, Chester, PA 19013-4511 USA
Tel: 1-(610) 876-3400 | Fax: 1-(610) 874-0190
www.communitypro.com

© 2012 All Rights Reserved

15AUG2012