

VLF Series

Versatile Low Frequency Systems

Models:

VLF208B / VLF208W
VLF212BI / VLF212WI
VLF212BP



Operation Manual



EC STATEMENT OF CONFORMITY

This document confirms that the range of products of Community Professional Loudspeakers bearing the CE label meet all of the requirements in the EMC directive 89/336/EEC laid down by the Member States Council for adjustment of legal requirements. Furthermore, the products comply with the rules and regulations referring to the electromagnetic compatibility of devices from 30-August-1995.

The Community Professional Loudspeaker products bearing the CE label comply with the following harmonized or national standards:

DIN EN 55013:08-1991

DIN EN 55020:05-1995

DIN EN 55082-1:03-1993

The authorized declaration and compatibility certification resides with the manufacturer and can be viewed upon request. The responsible manufacturer is the company:

Community Light & Sound
333 East 5th Street
Chester, PA 19013
USA

TEL: 1-610 876-3400
FAX: 1-610 874-0190

Chester, PA USA December 2011

Notice: Every effort has been made to insure that the information contained in this manual was complete and accurate at the time of printing. However, due to ongoing technical advances, changes or modifications may have occurred that are not covered in this manual.

TABLE OF CONTENTS

INTRODUCTION.....	4
IMPORTANT SAFETY INFORMATION.....	4
UNPACKING AND INSPECTION	5
VLF SPECIFICATIONS	7
ELECTRONIC CONTROLLER OPTIONS.....	8
RECOMMENDED DSP SETTINGS FOR THE VLF208.....	8
RECOMMENDED DSP SETTINGS FOR THE VLF212.....	9
DYNA-TECH™ SUBWOOFER PROTECTION SYSTEM.....	10
HIGH-PASS FILTERS.....	11
CONNECTING THE AMPLIFIER TO THE LOUDSPEAKER: VLF208 AND VLF212I	11
SELECTABLE HIGH-PASS OUTPUTS: VLF212P	13
CONNECTING THE AMPLIFIER TO THE LOUDSPEAKER: VLF212P.....	15
WIRING NEUTRIK TYPE CONNECTORS.....	16
RIGGING / SUSPENSION AND SAFETY	17
VLF MOUNTING BRACKETS AND ACCESSORIES.....	18
VLF-Y208 MOUNTING YOKE BRACKET	18
VLF-SAB STEERED ARRAY BRACKET	18
DIMENSIONAL DRAWINGS	19
WARRANTY INFORMATION AND SERVICE.....	22

TABLE OF FIGURES

No.	Figure	Page
1	Physical Features of a VLF208	6
2	Physical Features of a VLF212I	6
3	Physical Features of a VLF212P	6
4	VLF208 Frequency Response Unprocessed (Raw Data)	8
5	VLF208 Frequency Response Processed	8
6	VLF208 DSP Frequency Response	8
7	VLF212 Frequency Response Unprocessed (Raw Data)	9
8	VLF212 Frequency Response Processed	9
9	VLF212 DSP Frequency Response	9
10	VLF208 Input Panel	11
11	VLF212I Input Panel	12
12	Graph Depicting Response of High-Pass/Flat Switch	13
13	VLF212P Input Panel	15
14	Single amp Connections	16
15	VLF-Y208 Mounting Yoke	18
16	VLF-SAB Steered Array Bracket with VLF208	18
17	VLF-SAB Steered Array Bracket with VLF212	19
18	VLF208 Dimensions	19
19	VLF212I Dimensions	20
20	VLF212P Dimensions	21

VLF SERIES OPERATION MANUAL

INTRODUCTION

Thank you for selecting Community's Versatile Low Frequency (VLF) Series. VLF is a series of powerful and innovative new low frequency subwoofers that feature a compact, low-profile design ideal for theaters, restaurants, auditoria, houses of worship, schools and other venues, fitting into areas where larger subwoofers are impractical. VLF Series loudspeakers are designed for demanding day-to-day use in a wide range of fixed and portable installations. Their high quality driver components are housed in rugged, acoustically inert enclosures equipped with rigging fittings.

This manual covers the VLF208 compact dual 8-inch micro subwoofer, the VLF212I compact dual 12-inch subwoofer for permanent installation, and the VLF212P "portable" version of the VLF212I with built-in handles and pole mount socket.

VLF subwoofers offer numerous features and advances in technology. Some of these include:

- Low profile design, small footprint
- Designed to work as a traditional subwoofer or in steered bass arrays
- DYNA-TECH™ protection circuitry reduces the likelihood of driver damage under abusive conditions.
- Load-rated threaded rigging fittings for safe & easy rigging.
- NL4-compatible locking connector with terminal strip for easy connectivity.
- Suitable for in-wall, under-seating, under-stage and other "hidden" LF applications
- Optional factory designed mounting brackets available from stock.
- Available in black or white finish at no additional cost.

IMPORTANT SAFETY INFORMATION

Always follow these basic safety precautions when using or installing VLF loudspeakers and accessories:

1. Read these instructions.
2. Keep these instructions.
3. Heed all warnings.
4. Follow all instructions, particularly those pertaining to rigging, mounting, hanging and electrical connections.
5. Only use accessories that are specified and approved by the manufacturer.

The terms CAUTION, WARNING, and DANGER are used throughout this manual to alert the reader to important safety considerations. If you have any questions or do not understand the meaning of these terms, do not proceed with installation. Contact your local dealer, distributor, or call Community directly for assistance. These terms are defined below:



CAUTION: describes an operating condition or user action that may expose the equipment or user to potential damage or danger.

WARNING: describes an operating condition or user action that will likely cause damage to the equipment or injury to the user or to others in the vicinity.

DANGER: describes an operating condition or user action that will immediately damage the equipment and/or be extremely dangerous or life threatening to the user or to others in the vicinity.

The loudspeakers described in this manual are designed to be 'flown' or suspended for maximum acoustical performance using a variety of rigging hardware, means, and methods in some applications. It is essential that all installation work involving the suspension of these loudspeaker products be performed by competent, knowledgeable persons who understand safe rigging practices. Severe injury and/or loss of life may occur if these products are improperly installed. Please read the section on rigging for additional information.

UNPACKING AND INSPECTION

VLF loudspeakers are inherently rugged and are carefully packed in sturdy cartons. However, it is wise to thoroughly inspect each unit after it has been removed from the packaging, as damage could occur during shipping.

Please note that once the shipment has left your dealer or the Community factory, the responsibility for damage is *always* borne by the freight company. If damage has occurred during shipping, you must file a claim directly with the freight company. It's very important to contact the freight company as soon as possible after receiving your shipment, as most freight companies have a short time limit within which they will investigate claims. Make sure to save the carton and the packing material, as most claims will be denied if these materials are not retained. Your Community dealer and the factory will try to help in any way they can, but it is the responsibility of the party receiving the shipment to file the damage claim.

It's always a good idea to retain the carton and packing materials indefinitely, if possible, in the event that the unit may need to be returned to your dealer or distributor for repair in the future.

Each shipping carton contains the following items:

- VLF Loudspeaker System (Qty 1)
- Owner's Guide (Qty 1)
- Warranty Card (Qty 1)



DANGER: VLF rigging fittings are rated at a Working Load Limit (WLL) of 100 lbs (45.4kg) with a 10:1 safety margin. No single rigging fitting should ever be subjected to a load that is greater than this stated limit. Failure to heed this warning could result in injury or even death!



IMPORTANT: The flat-head Allen-drive rigging screws that come installed in each enclosure must either be replaced with rigging brackets and threaded fasteners, or they must be kept in place to seal the enclosure from air leaks. If the rigging fittings do not remain sealed, air leaks will occur in the enclosure that will compromise the low-frequency performance with distortion and reduced output.

Figure 1: Physical Features of a VLF208

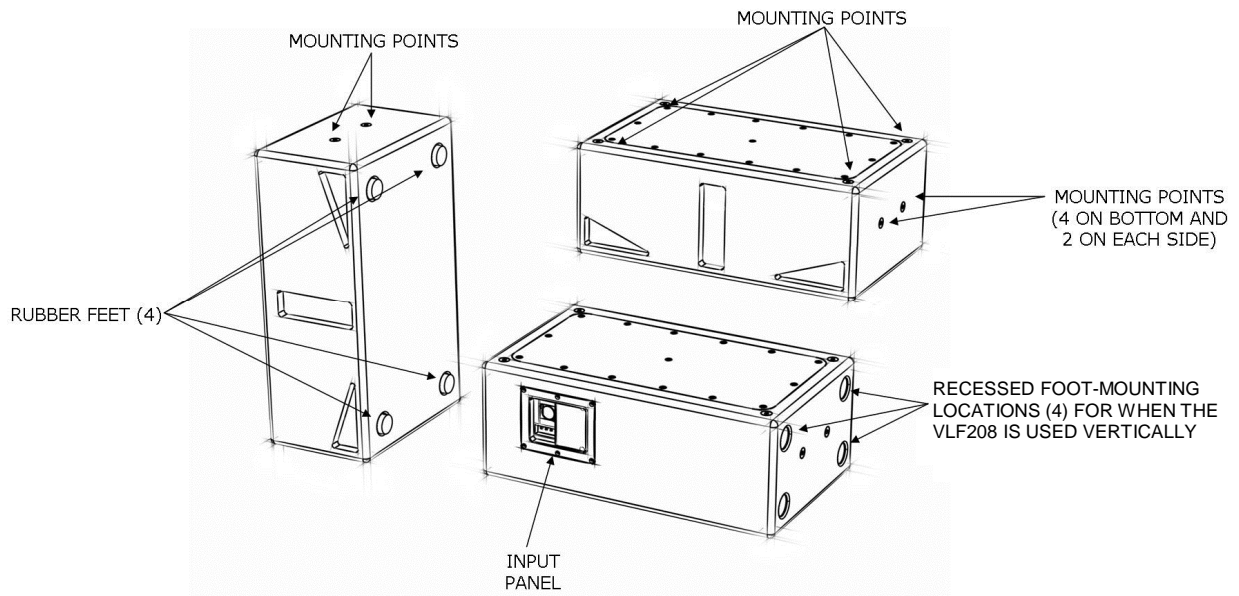

Figure 2: Physical Features of a VLF212I

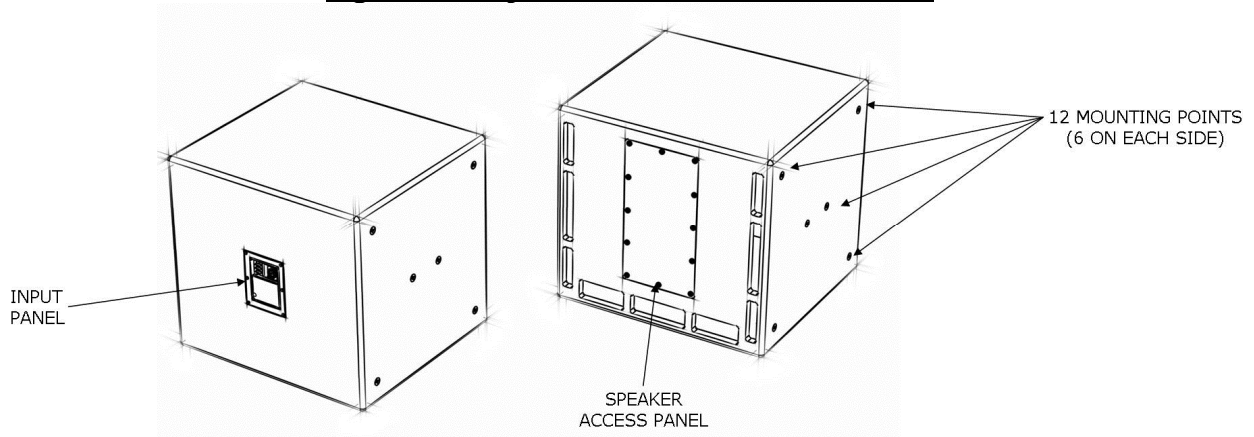
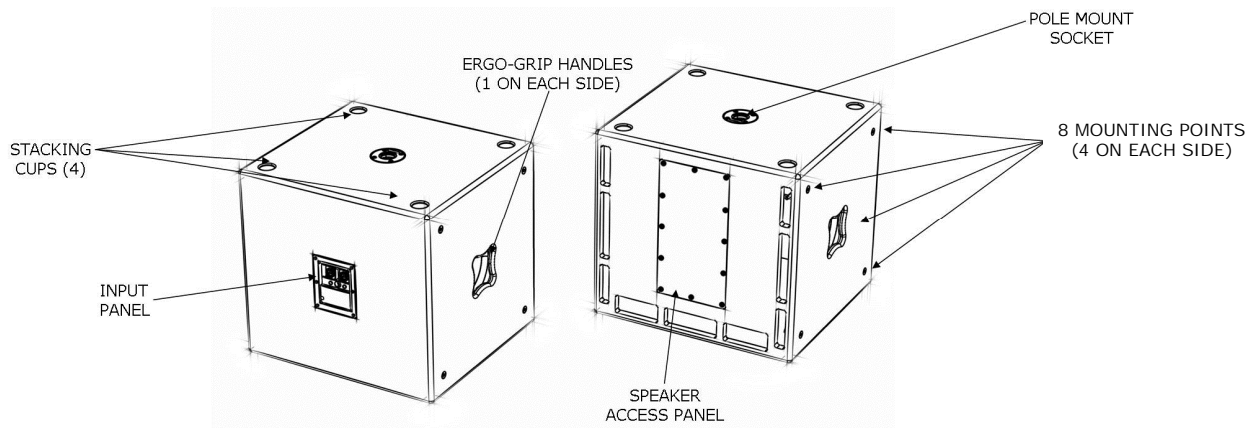

Figure 3: Physical Features of a VLF212P



VLF SPECIFICATIONS

Model	VLF208	VLF212I	VLF212P
Loudspeaker Type	Compact Subwoofer	Compact Subwoofer	Compact Subwoofer
Driver Complement	LF: 2 x 8"	LF: 2 x 12"	LF: 2 x 12"
Operating Range	55 Hz – 400 Hz	35 Hz – 200 Hz	35 Hz – 200 Hz
Frequency Response	60 Hz – 160 Hz \pm 1dB processed	43 Hz – 160 Hz \pm 2dB processed	43 Hz – 160 Hz \pm 2dB processed
Input Ratings	300W RMS 750W PGM	300W RMS 750W PGM	300W RMS 750W PGM
Sensitivity 1W/1m	95 dB SPL (63 Hz – 160 Hz 1/3 octave bands) ¹	97 dB SPL (50 Hz – 160 Hz 1/3 octave bands) ¹	97 dB SPL (50 Hz – 160 Hz 1/3 octave bands) ¹
Maximum SPL Continuous Peak	120 dB SPL / 127 dB SPL (peak)	122 dB SPL / 129 dB (peak)	122 dB SPL / 129 dB (peak)
Nominal Impedance	4 Ohms	4 Ohms	4 Ohms
Input Connection	(1) NL4-compatible locking connector (1) 2 conductor barrier strip	(1) NL4-compatible locking connector (1) 2 conductor barrier strip	(2) NL4-compatible locking connector (2) ¼" jack with high-pass output switch
Rigging Provisions	(8) M10 hang points	(12) M10 hang points	(8) M10 hang points
Construction	11-ply cross laminated birch	11-ply cross laminated birch	11-ply cross laminated birch
Finish	Black or white paint finish	Black or white paint finish	Black paint finish
Height	8.25 in / 210 mm	20 in / 508 mm	20 in / 508 mm
Width	21.75 in / 552 mm	21.75 in / 552 mm	21.75 in / 552 mm
Depth	13 in / 330 mm	20 in / 508 mm	20 in / 508 mm
Net Weight	42 lbs / 19.1 kg	88 lbs / 39.9 kg	88 lbs / 39.9 kg

¹Half Space pink noise measurement at 4 ft. (1.2m) at 25% power; extrapolated to 1m and an input of 2 Volts RMS.

Due to ongoing development, specifications are subject to change without notice.



VLF208



VLF212I



VLF212P

ELECTRONIC CONTROLLER OPTIONS

VLF subwoofers are intended to be controlled by a digital signal processor (DSP) that directly precedes the power amplifier in the signal chain. The controller processes the audio signal to provide an optimized signal to the loudspeaker under all operating conditions. This results in improved frequency response, maximized power handling, lower distortion and increased protection for the loudspeaker components.

Recommended DSP Settings for the VLF208

High-Pass Filter: Linkwitz 48 dB/Oct, 55 Hz

Low-Pass Filter: Butterworth 48 dB / Oct, 200 Hz (Varies based on the full-range system used)

Filter Type	PEQ1	PEQ2	PEQ3	PEQ4
Frequency	58 Hz	70 Hz	110 Hz	248 Hz
Gain	+9 dB	+5.5 dB	-2 dB	-7 dB
Slope/Q	0.2 Oct	0.33 Oct	1 Oct	0.33 Oct

Figure 4: VLF208 Frequency Response Unprocessed (Raw Data):

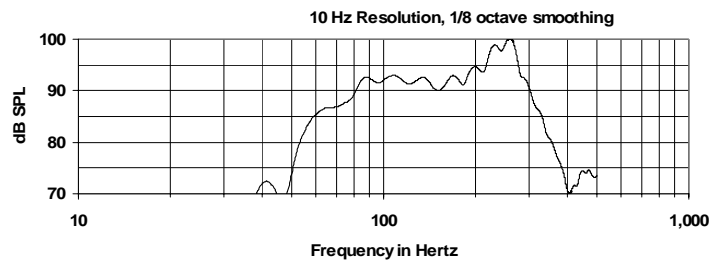

Figure 5: VLF208 Frequency Response Processed:

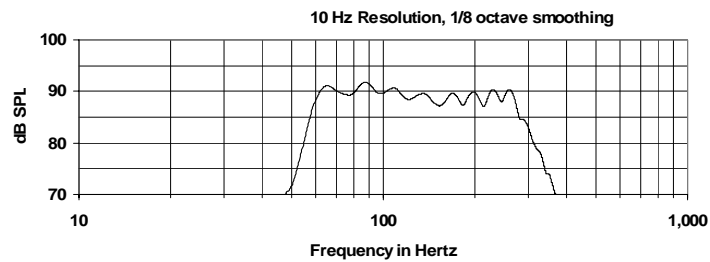
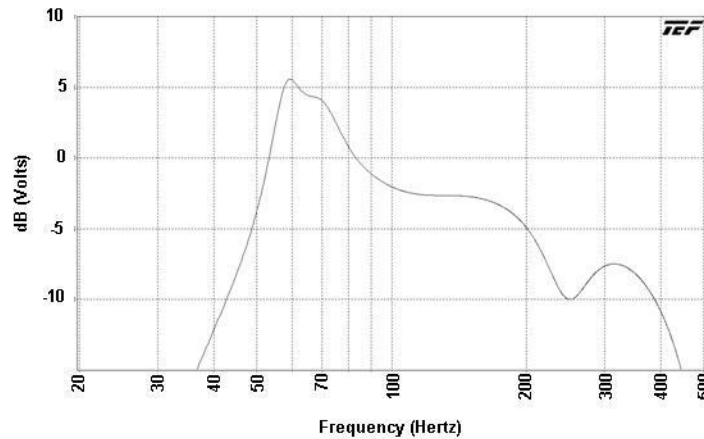

Figure 6: VLF208 DSP Response Frequency:



Recommended DSP Settings for the VLF212

High-Pass Filter: Butterworth 48 dB/Oct, 35 Hz

Low-Pass Filter: Butterworth 48 dB/Oct, 200 Hz (Varies based on the full-range system used)

Filter Type	PEQ1	PEQ2	PEQ3	PEQ4	PEQ5
Frequency	38 Hz	45 Hz	62 Hz	110 Hz	200 Hz
Gain	+4.5 dB	+2.5 dB	-3 dB	+1 dB	-7 dB
Slope/Q	0.20 Oct	0.19 Oct	0.5 Oct	1 Oct	0.33 Oct

Figure 7: VLF212 Frequency Response Unprocessed (Raw Data):

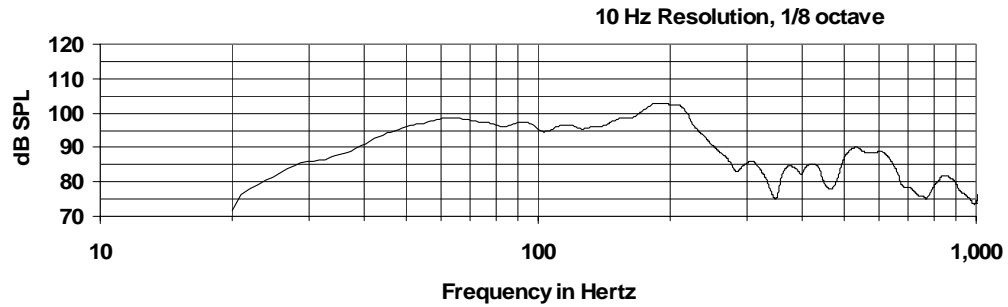

Figure 8: VLF212 Frequency Response Processed:

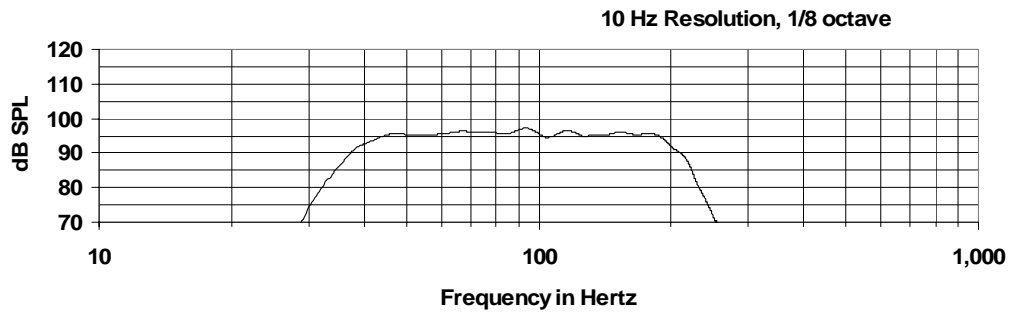
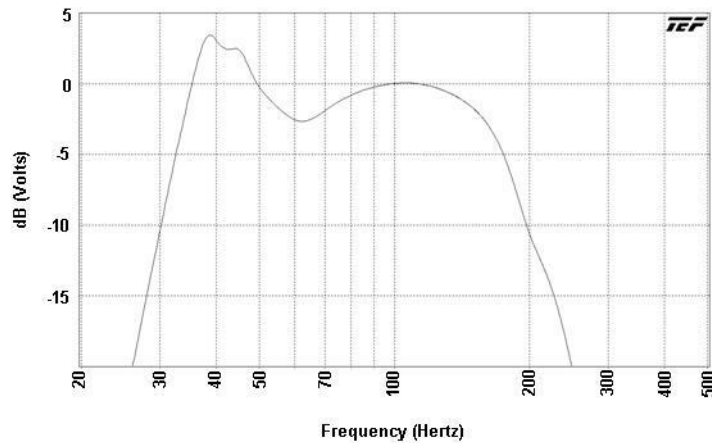

Figure 9: VLF212 DSP Response Frequency:



DYNA-TECH™ SUBWOOFER PROTECTION SYSTEM

VLF208 and VLF212 loudspeakers employ Community's advanced technology DYNA-TECH driver protection system. Functioning as a multi-stage limiter, DYNA-TECH circuitry provides precise and repeatable protection by reducing excessive power to the drivers under abusive conditions.

The limiting protects the drivers from damage due to excessive power levels being applied. This limiter is based on an electromechanical relay driven through a voltage sensing circuit. The relay engages at a predetermined voltage, corresponding to a power level that would otherwise cause driver damage. When engaged, the relay introduces a bank of high-wattage resistors in series with the drivers. These resistors cause a voltage drop to the drivers, thereby reducing the power applied to them. On the VLF212P, a red LED on the rear panel indicates that this protection circuit has been engaged (the VLF208 & VLF212I do not have this indication LED).

When the relay protection circuit is activated, there will be a noticeable drop in the system's level (approximately 3 to 4 dB). The red LED, as well as the drop in level, serves as a warning to the operator that the loudspeaker is being overdriven. *When this stage of protection is engaged, the level of the console and/or the amplifier's output to the system should be reduced.*



IMPORTANT: If the operator continues to run the system at excessive levels, or worse, if the operator raises the drive level to compensate for the drop in output caused by the protection circuitry, eventually a second stage of protection will engage that shuts down the system entirely (note that this additional stage of protection will never engage until *after* the first stage has been triggered). If the system shuts down entirely, the operator can immediately restore sound by simply reducing the drive level to the system.

Advantages of Community's DYNA-TECH Circuitry

There are numerous advantages to this type of multi-stage protection circuitry. The trip point is pre-set to engage at exactly the same time on all loudspeakers that are powered from the same amplifier. The initial stages of DYNA-TECH protection circuitry do not rely on, and are not affected by, heat buildup. Some manufacturers use circuit breakers that require heat buildup before they trip; this limits their ability to protect a cold speaker. The trip points of such breakers are also affected by ambient temperature, their own internal heating curves, and small variations in loudspeaker impedance or crossover component tolerances, all of which can cause unpredictable behavior.

Because the first stage of Community's DYNA-TECH circuit is not thermally sensitive, it reacts nearly instantaneously to protect against an excessive increase in level. Moreover, the protection disengages almost immediately when the drive level to the system is reduced; it is not necessary to wait for a circuit breaker to cool down. This means that your loudspeaker can operate at its full dynamic range and still react quickly to protect against excessive musical peaks, avoiding damage to the system. It also means that your loudspeaker is protected from the moment the power amplifier is plugged in and turned on, regardless of the ambient temperature.

As mentioned above, the protection circuitry provides a second level of protection for the entire loudspeaker to guard it from severe misuse. If the system is operated in the first stage mode of protection for a long period of time, or if the input level is increased to try to overcome the volume drop from the first-stage protection circuitry, a solid-state circuit breaker will trip and remove all signal from the loudspeaker until the input level is reduced.

Because this circuit breaker *is* heat sensitive, it provides a final level of protection that takes heat into account as well as power. However, unlike most implementations of circuit breakers that take time to cool down before resetting, DYNA-TECH circuits respond instantly to a reduction in level, restoring the system to its full dynamic range without needing to wait for the circuit breaker to reset itself.

HIGH-PASS FILTERS

The use of an external, active high-pass filter to protect the cone drivers from excessive low-frequency excursion is strongly encouraged. A high-pass filter will eliminate the potential of low-frequency modulation from wind noise, turntable rumble, stage vibration, and other causes that result in a poorly defined and 'muddy' bass response. Additionally, a high-pass filter will avoid wasting amplifier power by keeping the amplifier from attempting to reproduce frequencies below the loudspeaker's intended operating range. The table below shows the recommended filter settings:

Model	High-Pass Filter
VLF208 Subwoofer:	55 Hz, 24 dB/octave
VLF212I Subwoofer:	48 Hz, 24 dB/octave
VLF212P Subwoofer:	48 Hz, 24 dB/octave

CONNECTING THE AMPLIFIER TO THE LOUDSPEAKER: VLF208 AND VLF212I

The VLF208 and VLF212I come with two methods of connecting the amplifier to the loudspeaker. One is an industry standard NL4 type locking connector, and the other is a terminal strip. These two connectors are wired in parallel with each other, on all models.

Figure 10: VLF208 Input Panel

The loudspeaker is intended to be connected directly to the amplifier.

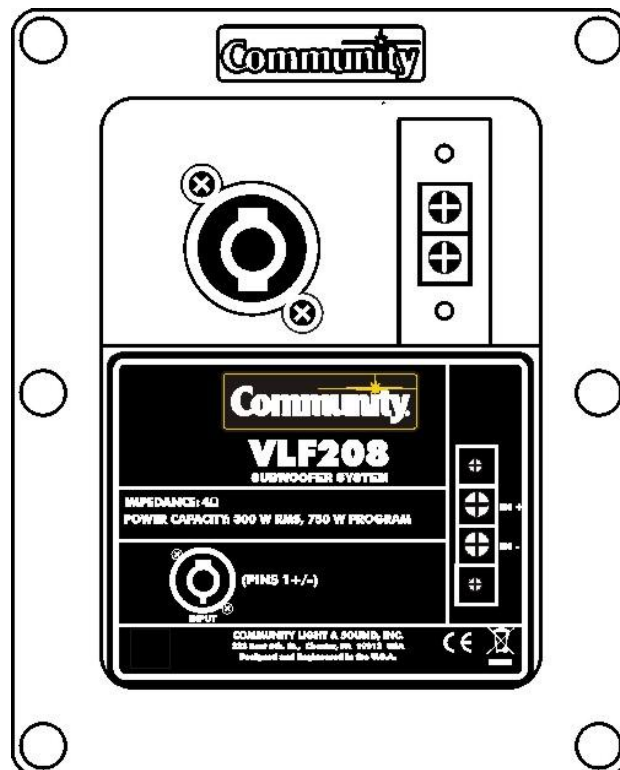
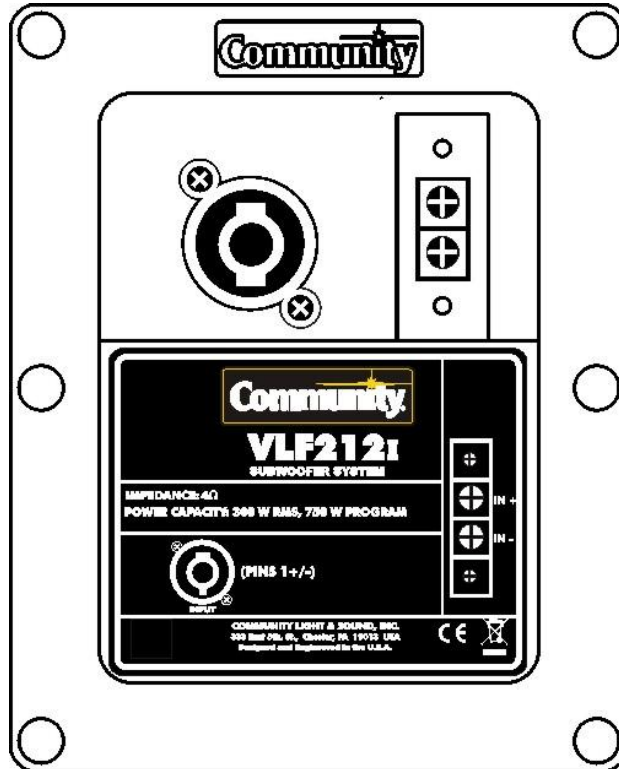

Figure 11: VLF212i Input Panel

The loudspeaker is intended to be connected directly to the amplifier.



PIN Designations

For all models the pin designation is as follows:

- NL4 Pin 1+ or the terminal screw labeled (+) connect to the positive (red) output of the amplifier.
- NL4 Pin 1- or the terminal screw labeled (-) connect to the negative (black) output of the amplifier.

Note that the NL-4 and the terminal strip are wired in parallel, and that Pins 2+ and 2- on the NL4 connector are not utilized.



CAUTION: Be sure to carefully observe polarity when wiring your loudspeakers. If one loudspeaker is wired with the opposite polarity from another loudspeaker, acoustic cancellation will occur. The result will be less acoustic power output than if only one loudspeaker were used by itself.

SELECTABLE HIGH-PASS OUTPUTS: VLF212P

The VLF212P subwoofer is equipped with an industry-standard NL4-compatible locking connector wired in parallel with a ¼" jack. A second NL4-compatible locking connector is provided, also wired in parallel to a ¼" jack. This second set of connectors is intended as OUTPUTS and are associated with the subwoofer's SWITCHABLE HIGH-PASS OUTPUT.

When the selector switch is set to the PARALLEL INPUT MODE (the *down* position), both the NL4-compatible locking connector and the 1/4" jack function exactly as loop-thru connectors; in other words they are simply wired in parallel with the INPUT CONNECTORS.

Conversely, when the selector switch is set to HIGH-PASS OUTPUT (the *up* position), a 1st order high-pass filter (6 dB per octave) is inserted into the circuit. The filter has a corner frequency of 125 Hz with an 8 ohm load.

Using the HIGH-PASS OUTPUT MODE inserts the HIGH-PASS FILTER as mentioned above, but it also presents a higher impedance load to the amplifier. This can become quite important, particularly if a pair of full-range loudspeakers and a subwoofer are being powered from a single amplifier channel. In the PARALLEL INPUT MODE, the impedance of the combined load could become dangerously low for some amplifiers, potentially causing the amplifier to shutdown or fail.

The following graph shows the difference in the total load impedance with the high-pass switch in the HIGH-PASS and PARALLEL INPUT MODE positions. The lower line depicts the response with the switch in the FLAT position where the load drops below 2 ohms between 30 – 50 Hz and again between 100 – 200 Hz, potentially causing early clipping, amplifier shutdown, or even amplifier failure. The upper line depicts the response with the switch in the HIGH-PASS position, where the load impedance has been *increased* by about 50% by the subwoofer's internal crossover circuit, thereby protecting the amplifier from premature clipping and potential failure.

Figure 12: Graph Depicting Response of HIGH-PASS / FLAT Switch
(Note: upper line depicts HIGH-PASS; lower line depicts FLAT)

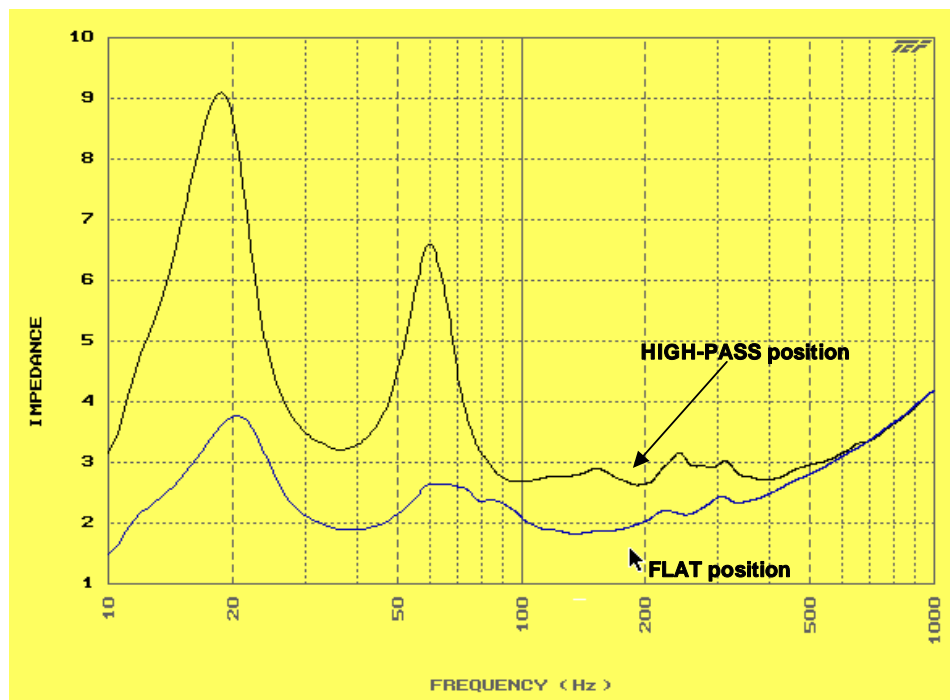

In addition to presenting a more amplifier-friendly load, the HIGH-PASS OUTPUT also attenuates the low-frequency energy that's fed to the full-range loudspeaker. This reduces the demand on the full-range loudspeaker's woofer, thereby freeing up some additional power and headroom in the upper part of the bass spectrum. Use of the HIGH-PASS OUTPUT will typically result in an overall flatter response, but with slightly less total power available in the mid-bass portion of the audio spectrum.

The results you achieve will be strongly influenced by the relative locations of the full-range loudspeaker(s) and the subwoofer(s), their position in relation to the walls, floor or ceiling, as well as the overall room acoustics. For example, if a full-range model is stacked on a subwoofer, the combined response will be different than if it is flown 15 or 20 feet over the subwoofer. We encourage you to experiment to obtain the quality of sound that is to your liking.



IMPORTANT: The corner frequency of the built-in HIGH-PASS FILTER on the VLF212P is load dependent (this is the case with *all* passive filters). This means that the frequency will alter if the impedance of the load changes. For example, if two 8 ohm full-range enclosures are connected to the high-pass output in parallel, the resultant 4 ohm load will change the high-pass corner frequency to 250 Hz.

For exact control in balancing the relative levels of the subwoofer(s) and the full-range loudspeaker(s), we recommend that separate amplifier channels be employed to power each unit individually. Moreover, if an electronic active crossover is used to divide the signal to the subwoofer(s) and the full-range loudspeaker(s), this will result in bi-amping the two systems. Bi-amping provides the benefit of reducing the overall power demand on each amplifier channel while reducing intermodulation distortion.

CONNECTING THE AMPLIFIER TO THE LOUDSPEAKER: VLF212P

Figure 13: VLF212P Input Panel



PIN Designations

In the Parallel Output Mode the pin designation is as follows:

- NL4 Pin 1+ and the *tip* of the ¼" jack connect to the positive (red) output of the amplifier.
- NL4 Pin 1- and the *sleeve* of the ¼" jack connect to the negative (black) output of the amplifier.

Internally, each of these pins are connected to the NL4 output connector, to the ¼" output jack, and to the drivers in the subwoofer.

In the Hi-Pass Mode the pin designation is as follows:

- NL4 Pin 1+ and the *tip* of the ¼" jack connect to the positive (red) output of the amplifier.
- NL4 Pin 1- and the sleeve of the ¼" jack connect to the negative (black) output of the amplifier.

Either the NL4 or the ¼" jack on the right side of the input panel may be used as hi-pass outputs to drive one or more full-range loudspeakers. These hi-pass outputs exhibit the response that is discussed in the section of this manual entitled "SELECTABLE HIGH-PASS OUTPUTS: VLF212P."

WIRING NEUTRIK TYPE CONNECTORS

The diagrams below show how connections are made to a Neutrik Speakon™ style loudspeaker connector. Terminations may be soldered, or made by means of their built-in screw and pressure clamp. If using the pressure clamp, it's important to tighten it fully, then to wait about ten minutes (longer is better), then to tighten it again. This is because copper wire *flows* under pressure. After initially tightening the screw clamp, some minutes later the screw will no longer be as tight due to the effect of the compression on the copper. Typically, only one cycle of "tighten – wait – re-tighten" is required for a secure connection.

Figure 14: Single Amp Connections

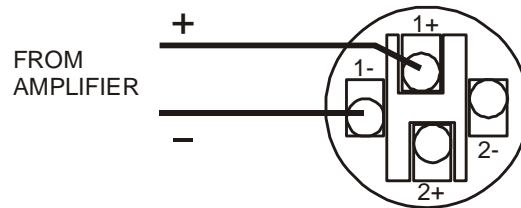

NEUTRIK SPEAKON
CONNECTOR -- NL4FC



DANGER: When wiring the amplifier(s) to the loudspeaker(s), always power-down the amplifier(s) and disconnect their AC Mains plug(s). Many modern, high power amplifiers can deliver enough voltage and current to cause a harmful or lethal electric shock. Shocks from very low frequencies, such as kick drums, can cause the human heart to stop beating at relatively low power levels.



WARNING: After wiring the amplifier(s) to the loudspeaker(s), first power up all devices that are upstream of the amplifier, such as mixers, equalizers, compressor/limiters, etc., *before* powering-up the amplifier. This is to avoid passing any clicks or pops that may originate in the upstream devices to the loudspeakers. The amplifier should initially be powered-up with its gain controls turned all the way down. After making sure that a continuous signal is present, such as a CD playing, slowly raise the level of the gain controls to establish that the wiring has been installed correctly. Only then should the loudspeaker be operated at normal output levels.

The VLF208 and VLF212I have one (1) NL4-compatible locking connector. The VLF212P has two (2) NL4-compatible locking connectors.

RIGGING / SUSPENSION AND SAFETY

The terms "rigging", "flying" and "suspension" are often used interchangeably in describing methods of installing loudspeaker systems at elevated positions.



DANGER: The loudspeakers described in this manual are designed and intended to be suspended using a variety of rigging hardware, means, and methods. It is essential that all installation work involving the suspension of these loudspeaker products be performed by competent, knowledgeable persons who understand safe rigging practices. Severe injury and/or loss of life may occur if these products are improperly suspended.



DANGER: All rigging fittings must remain sealed with the included flat-head allen screws or they must be fitted with properly rated optional mounting hardware. Any missing fasteners will compromise the structural integrity of the enclosure and constitute a safety hazard. Do not suspend this loudspeaker unless all fasteners are securely in place!

COMMUNITY RIGGING HARDWARE WARRANTY: Community warrants that its loudspeaker systems and its optional mounting and rigging hardware have been carefully designed and tested. Community loudspeakers may be safely suspended when each loudspeaker model is suspended with Community-manufactured optional mounting and rigging brackets specifically designed for use with that particular model of loudspeaker. This warranty applies only for use under normal environmental conditions, and when all loudspeakers, component parts, brackets and hardware are assembled and installed in strict accordance with Community's installation guidelines contained herein. Beyond this, Community assumes no further or extended responsibility or liability, in any way or by any means whatsoever. It is the responsibility of the installer to insure that safe installation practices are followed, and that such practices are in accordance with any and all local, state, federal, or other, codes, conditions, and regulations that may apply to, or govern the practice of, rigging, mounting, and construction work in the relevant geographic territory. Any modifications made to any parts or materials manufactured or supplied by Community shall immediately void all pledges of warranty or surety, related in any way to the safe use of those parts and materials.



WARNING - NON-COMMUNITY RIGGING HARDWARE: Non-Community hardware used for rigging a VLF loudspeaker must be certified by the supplier for this use and must be properly rated for safety.

Important Notes on Rigging Loudspeakers

There are three areas of responsibility for rigging loudspeakers. The first is the building structure. Always consult with the building architect or structural engineer to assure the ability of the structure to support the loudspeaker system. The second area of responsibility is the loudspeaker itself. Community certifies its loudspeaker systems and rigging accessories for suspension when they are properly installed according to our published guidelines. The third area of responsibility is everything between the loudspeaker and the building structure and the actual process of installation. The installing contractor assumes this responsibility. Loudspeaker rigging should be performed only by certified rigging professionals using certified rigging hardware chosen for the specific application. Prior to installation, the contractor should present a rigging plan, with drawing and detailed parts list, to a licensed structural engineer (P.E.) or architect for written approval.

VLF MOUNTING BRACKETS AND ACCESSORIES

Below are descriptions of optional accessories manufactured by Community for use with VLF loudspeakers. In this section the terms “suspension” and “fly” mean the same thing: to elevate the loudspeaker enclosure above the ground surface. Consult the user’s guide included with each part for detailed safety instructions. It is the responsibility of the installer to insure that safe installation practices are followed. Installation of loudspeakers should only be performed by trained and qualified personnel. It is strongly recommended that a licensed and certified professional structural engineer approve the mounting design.



IMPORTANT: All rigging fittings should remain sealed, otherwise air leaks will occur in the enclosure that can compromise the low-frequency performance with distortion and reduced output.



WARNING: VLF rigging fittings are rated at a Working Load Limit of 100 lbs (45.4kg) with a 10:1 safety margin. No single rigging fitting should ever be subjected to a load that is greater than 100 lbs. Failure to heed this warning could result in injury or death!

VLF-Y208 Mounting Yoke Bracket

The VLF-Y208 yoke bracket is designed to mount the VLF208 subwoofer in either a vertical or horizontal orientation. It is engineered to provide a high margin of safety when supporting the VLF208 subwoofer. Yokes are manufactured of steel, covered with a durable powder-coat finish, and are available in either black or white to match the color of the enclosure.

Figure 15: VLF-Y208 Mounting Yoke

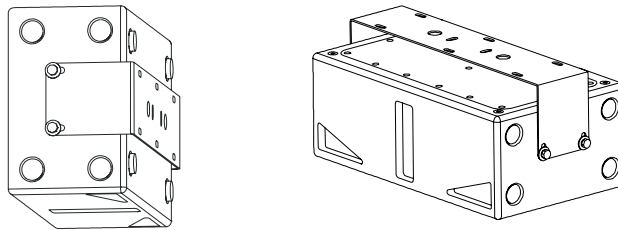

VLF-SAB Steered Array Bracket

The VLF Steered Array Bracket enables the construction of cardioid bass arrays, steered bass arrays, or vertical bass columns of VLF212 and VLF208 subwoofers, or combinations of both. Designated the VLF-SAB, it is intended for use only with Community’s VLF212 and VLF208 subwoofer systems, which share a common width of 21.75 inches.

Figure 16: VLF-SAB Steered Array Bracket with VLF208

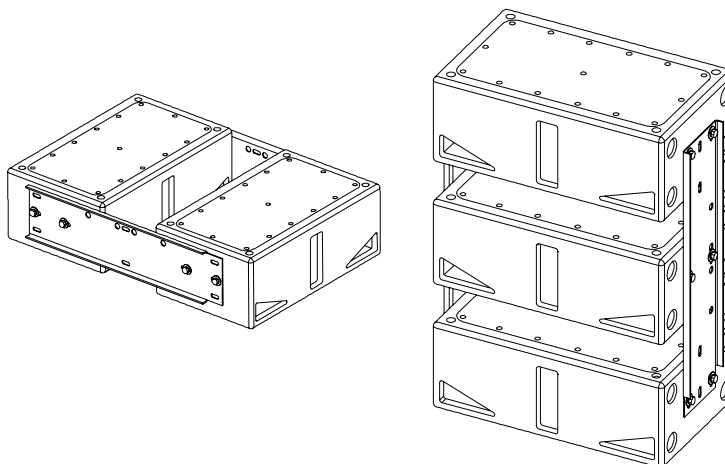
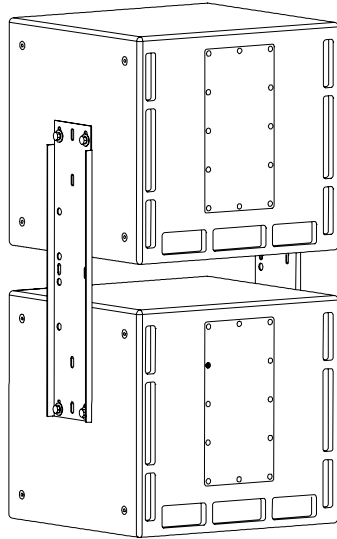

Figure 17: VLF-SAB Steered Array Bracket with VLF212



DIMENSIONAL DRAWINGS

Figure 18: VLF208 Dimensions

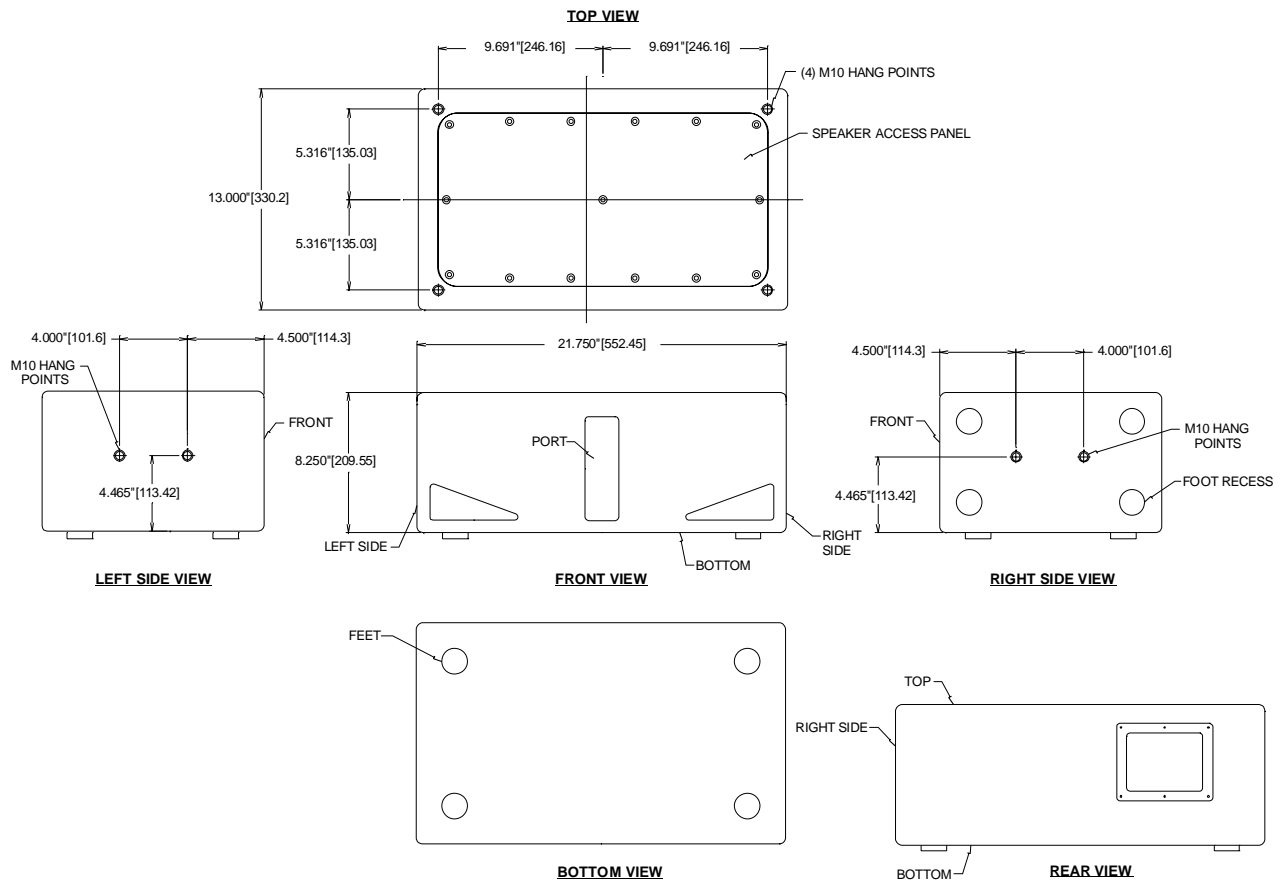

Figure 19: VLF212I Dimensions

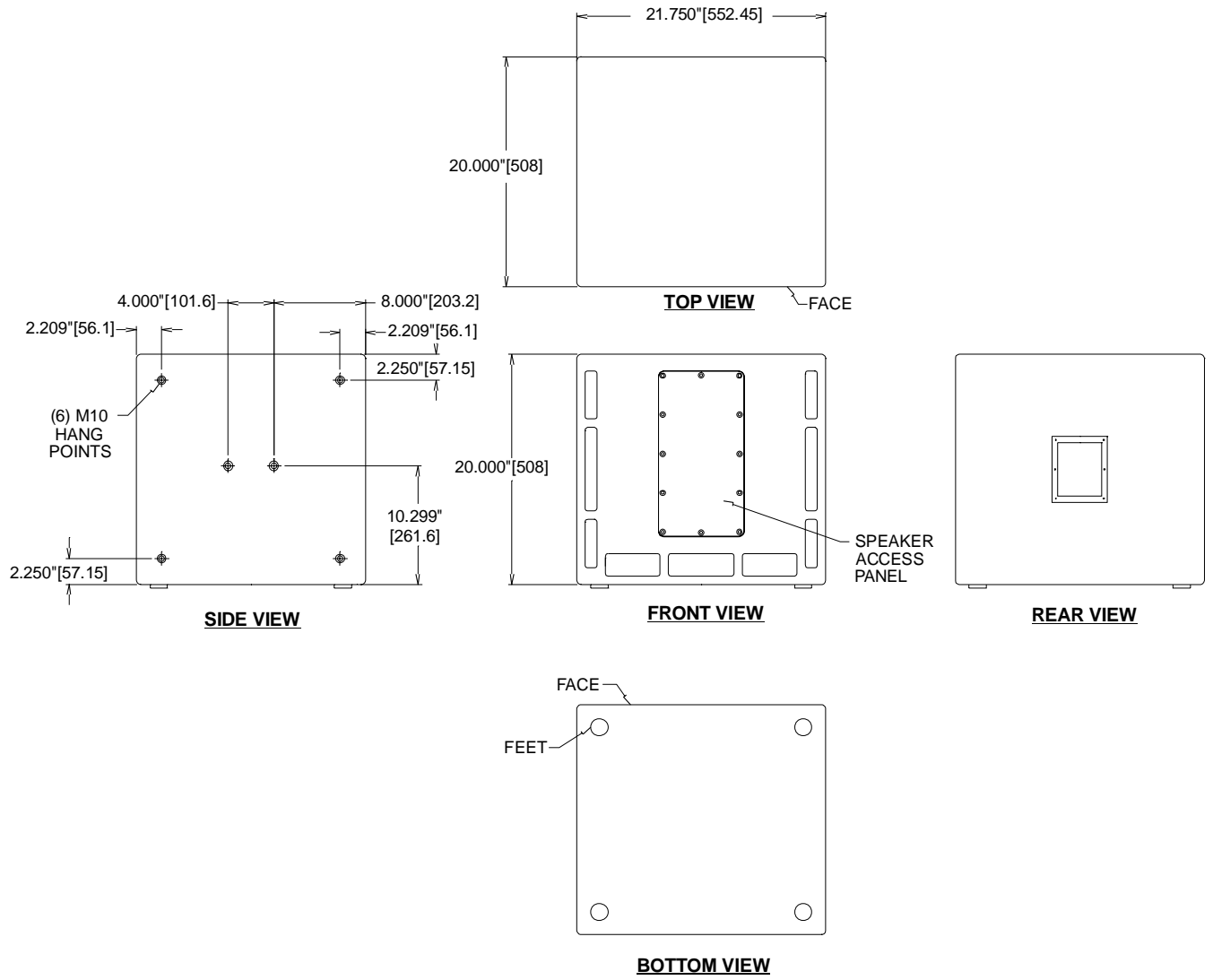
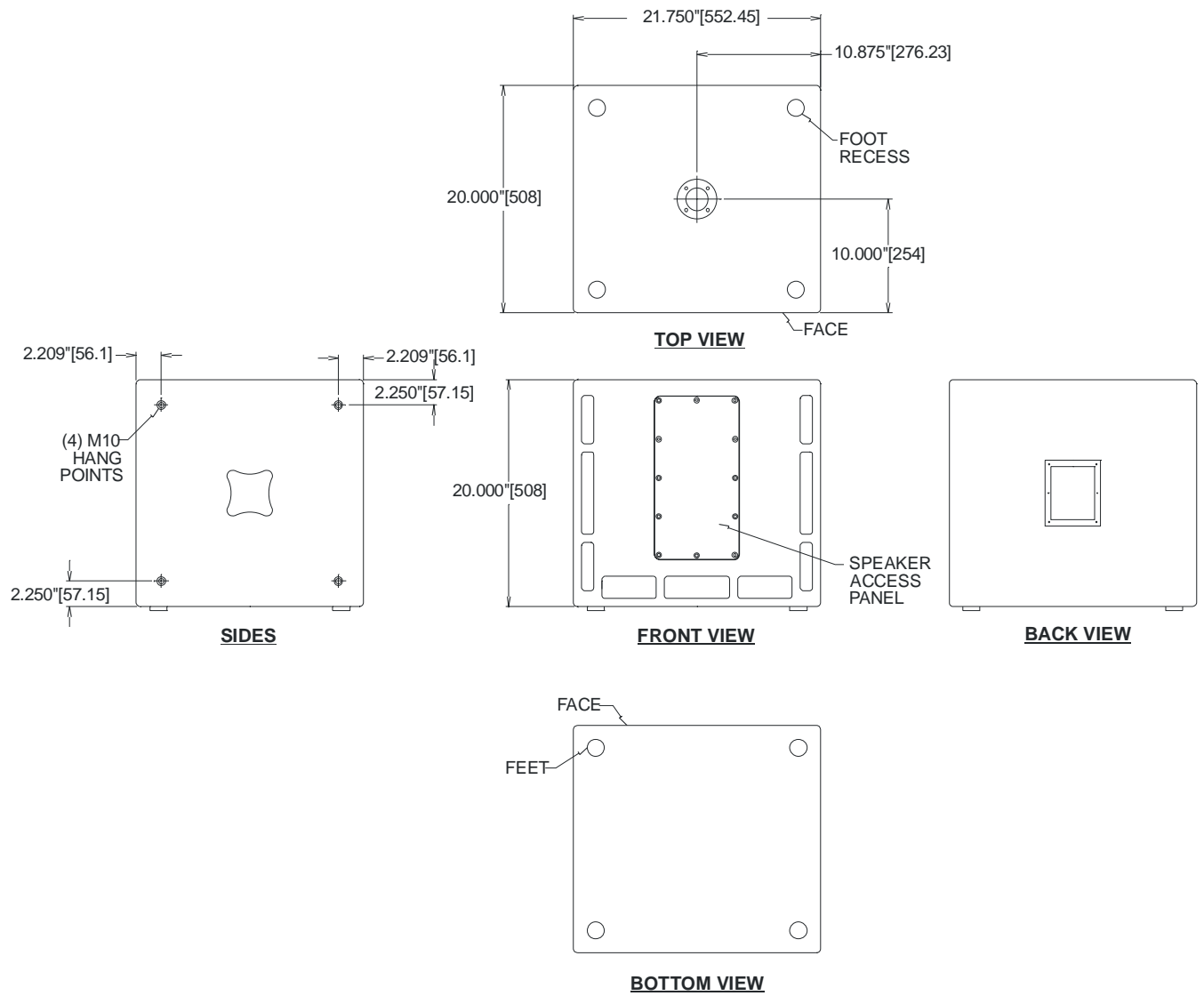

Figure 20: VLF212P Dimensions



WARRANTY INFORMATION AND SERVICE

Transferable Warranty " (Limited)" Valid in the USA Only

Community loudspeaker systems are warranted in the USA to be free from manufacturing defects in materials and workmanship for a period of five years, as determined by one of the following two methods, whichever is longer:

Starting from the date of retail purchase, as noted on the sales receipt from an authorized Community dealer,

OR

Starting from the date of manufacture, determined by the serial number, if the sales receipt is not available.

This warranty applies to the product; therefore, the remainder of the warranty period will be automatically transferred to any subsequent owner.

This warranty applies only to failure of a Community loudspeaker caused by defects in materials and workmanship during the stated warranty period. It does not apply to a unit that has been subjected to abuse, accident, modification, improper handling/installation, or repairs made without factory authorization or by anyone other than authorized Community Field Service Stations. This warranty is void if the serial number has been defaced, altered or removed.

Products covered by this warranty will be repaired or replaced at the option of Community, without charge for materials or labor, provided all the terms of this warranty have been met.

Obtaining Warranty Service

Warranty service may be obtained from the factory, or from an authorized Field Service Station.

To obtain factory or field warranty service for products purchased in the United States, return the product for inspection to the address below, freight prepaid, in the original packaging. If the original packaging is not available, call or write Community Warranty Service to obtain proper packaging materials or hand carry the product to the nearest Field Service Station.

Factory Service Center:

Community Warranty Service
333 East Fifth Street
Chester, PA 19013-4511 USA

Field Service Station:

Call (610) 876-3400 for the nearest Authorized Field Service Station

For factory service, please call (610) 876-3400 for a Return Authorization (R/A) number before shipping. The following information must be included in the package:

Owner's complete name, daytime phone number, return street address and return authorization number.

The serial number of the product being returned and a copy of the retail sales receipt, if possible.

A complete description of the problem(s) experienced, including a brief description of how the equipment is being used and with what brand, model and output power of amplifier.

Upon receipt, the service center will determine if the problem is covered under warranty. If covered under this warranty, the product will be repaired or replaced, at Community's option, and returned to the owner freight prepaid. If the problem is not covered under this warranty, the owner will be notified of the problem with an estimate of the repair costs.

Consequential and Incidental Damages: Community shall not be liable for any consequential or incidental damages including, without limitation, injury to persons, property, or loss of use. Some states do not allow the exclusion or limitations of consequential or incidental damages, so the above limitations and exclusions may not apply.

This Community warranty is not extended by the length of time which an owner is deprived of the use of the product. Repairs and replacement parts provided under the terms of this warranty shall carry only the remaining portion of the warranty.

Community reserves the right to change the design of any product from time to time, without notice and with no obligation to make corresponding changes in products previously manufactured.

While this warranty gives specific legal rights, there may also be other rights that vary from state to state. No action to enforce this warranty shall be permitted ninety days after expiration of the warranty period.

Warranty Information and Service for Countries Other Than the USA

To obtain specific warranty information and available service locations for countries other than the United States of America, contact the authorized Community Distributor for your specific country or region.



Community Professional Loudspeakers
333 East Fifth Street, Chester, PA 19013-4511 USA
Tel: 1-(610) 876-3400 | Fax: 1-(610) 874-0190
www.communitypro.com

© 2012 All Rights Reserved
21AUG2012