

INSTRUCTION BOOK FOR
Mobile Plasma Stand
Manual Confidence Monitor
MPS-MCM



Mobile Plasma Stand Manual Confidence Monitor MPS-MCM

⚠ CAUTION: The user of this product should exercise caution when moving the Mobile Plasma Stand. Any sudden stop could cause instability of the stand and could cause serious injury and/or damage. The stand should always be pushed, never pulled, by the user. Always push from the side of the stand, never from the front or back of the stand.

Required Tools:

- 7/16" wrench
- 9/16" wrench
- 3/16" allen wrench
- Phillips screwdriver

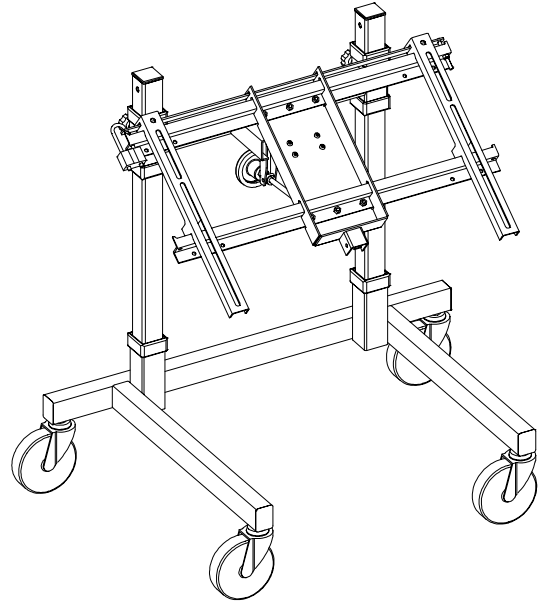

Included Parts

Item	Description	QTY	Item	Description	QTY
1	Security Bar	1		Package Set	1
2	Hanging Bracket	2	M	Padlock W/ Keys	1
3	Zee-Bar Plate Assembly	1		Package Set	1
4	Screw Weld Assembly	1	N	Screw, SHCS M8 x 20mm	4
5	Tube Weld Assembly	1	P	Washer, Flat 3/8"	4
6	Top Assembly	1	Q	Wrench, Allen 6mm	1
7	Column	2		Package Set	1
8	Base Assembly	1	R	Screw, SHCS M6 x 20mm	4
9	Glide, Furniture	2	S	Washer, Flat 1/4"	4
10	Caster, 5" W/ Brake	2	T	Washer, Allen 5 mm	1
11	Caster, 5"	4		Package Set	1
A	End Closure, 1-1/2" x 2"	4	U	Screw, SHCS M5 x 20mm	4
B	End Closure, 1-3/4", Square	2	V	Screw, SHCS M4 x 12mm	4
C	Knob, 3" Diameter	1	W	Washer, Flat #10	4
D	Nut, Hex 1/4"-20 Keps	4	X	Washer, Flat #8	4
E	Nut, Hex 1/4"-20 Nylon Lock	1	Y	Wrench, Allen 4mm	1
F	Nut, Hex 3/8"-16	1	Z	Wrench, Allen 3mm	1
G	Screw, BHSCS 1/4"-20 x 1/2"	6		Package Set	1
H	Screw, Mach 1/4"-20 x 2 1/2"	1	H	Screw, Mach 1/4"-20 x 2 1/2"	1
J	Screw, HHCS 3/8"-16 x 1"	4		E Nut, Hex 1/4"-20 Nylon Lock	1
K	Spacer	2	D	Nut, Hex 1/4"-20 Keps	1
L	Wrench, Allen 5/32"	1			

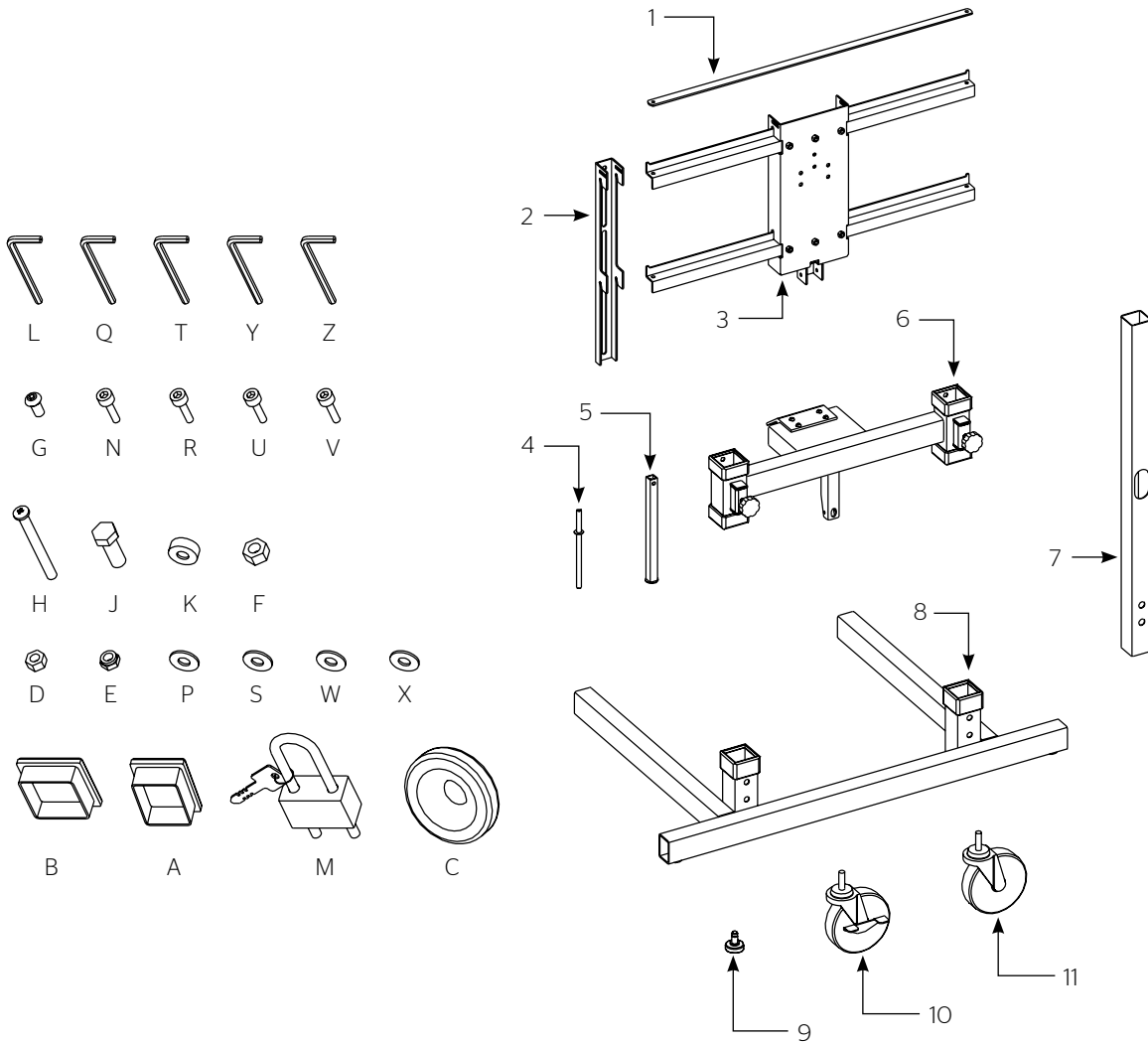

Procedure

1. Remove contents from carton and examine for damaged or missing parts.
2. Insert the Caster stems or Glide stems into the Base. See Figure 1. Must go in straight.

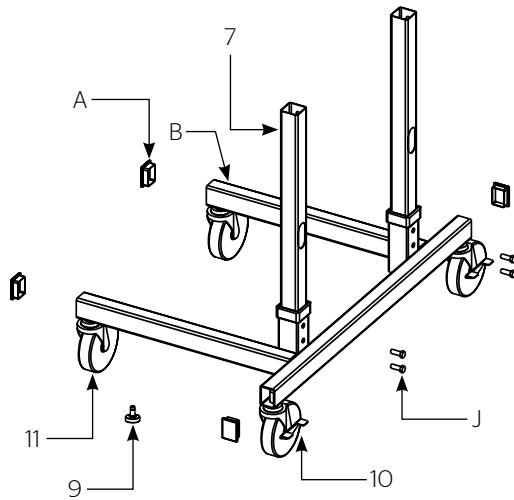

Figure 1

3. Insert tube enclosures shown.
4. Insert two Columns into the Base and install the fasteners shown. Leave loose at this time.
5. Slide the Top Assembly down the Columns. See Figure 2. Position the Top by tightening both Knobs. Make sure unit is level.

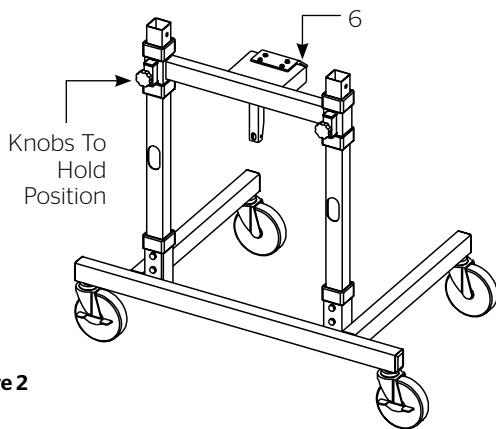

Figure 2

6. Tighten the fasteners at the bottom of the Columns.
7. Attach Zee-Bar Plate to Hinge. See Figure 3.

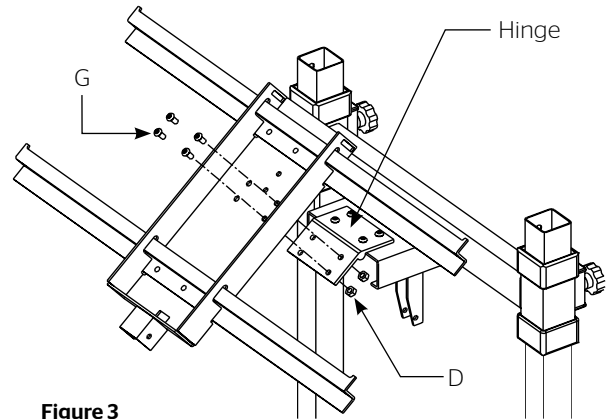

Figure 3

8. Attach tilt control mechanism to Top Assembly and Zee-Bar Assembly. See Figure 4.

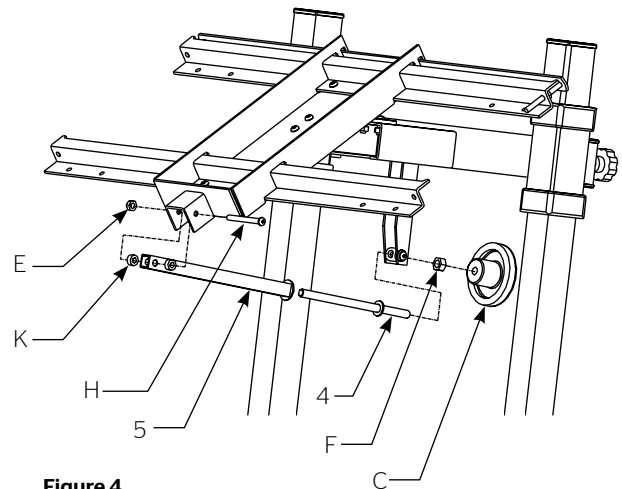

Figure 4

9. Mount the Hanging Brackets to the back of the monitor utilizing all the fastener points recommended by the monitor manufacturer. See Figure 5.

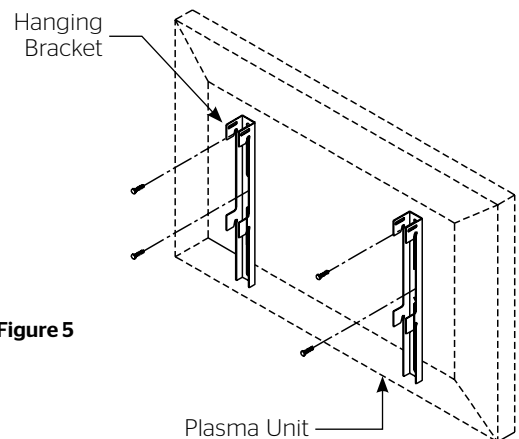

Figure 5

Procedure (Continued)

10. Hang the monitor on the Zee-Bars making sure the top and bottom notches on each Hanging Bracket are placed over the upper and lower Zee-Bars.
11. Slide the Security Bar through the slots in the Hanging Brackets, bolt one end to the Zee-Bar then secure the opposite end with the pad lock. See Figure 6 & 7.

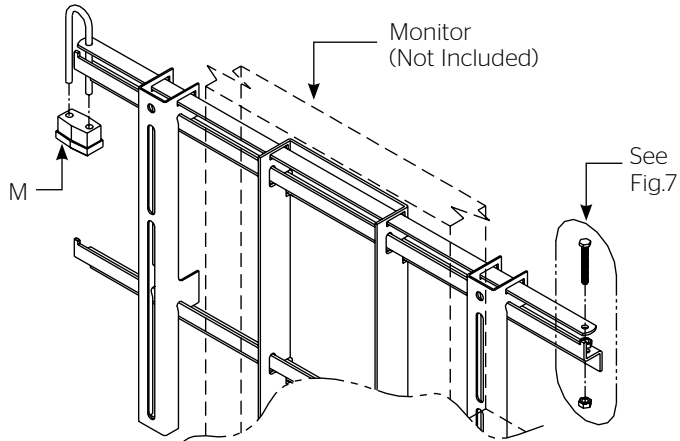

Figure 6

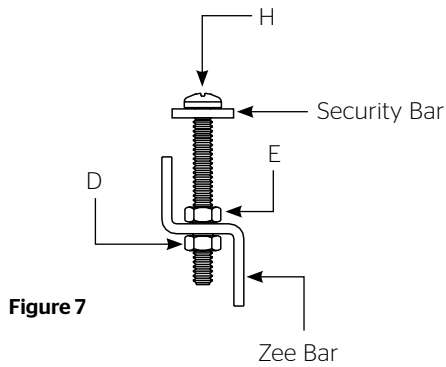

Figure 7

12. Install tube enclosures. See Figure 8.

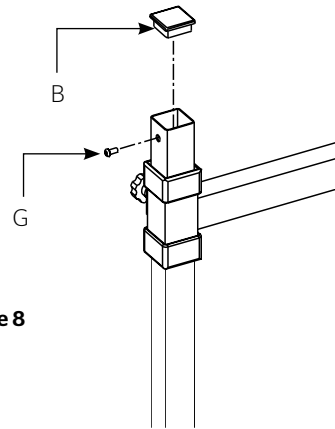

Figure 8

13. Install fasteners into top of Columns for theft deterrent.



A Milestone AV Technologies Brand

3100 North Detroit Street
Warsaw, Indiana 46582
P: 574.267.8101 or 800.622.3737
F: 574.267.7804 or 877.325.4832
E: info@da-lite.com
www.da-lite.com

DL-0382 (Rev. 2) 04.15

© 2015 Milestone AV Technologies LLC. Printed in U.S.A.