

Live X

Passive Loudspeaker Owner's Manual

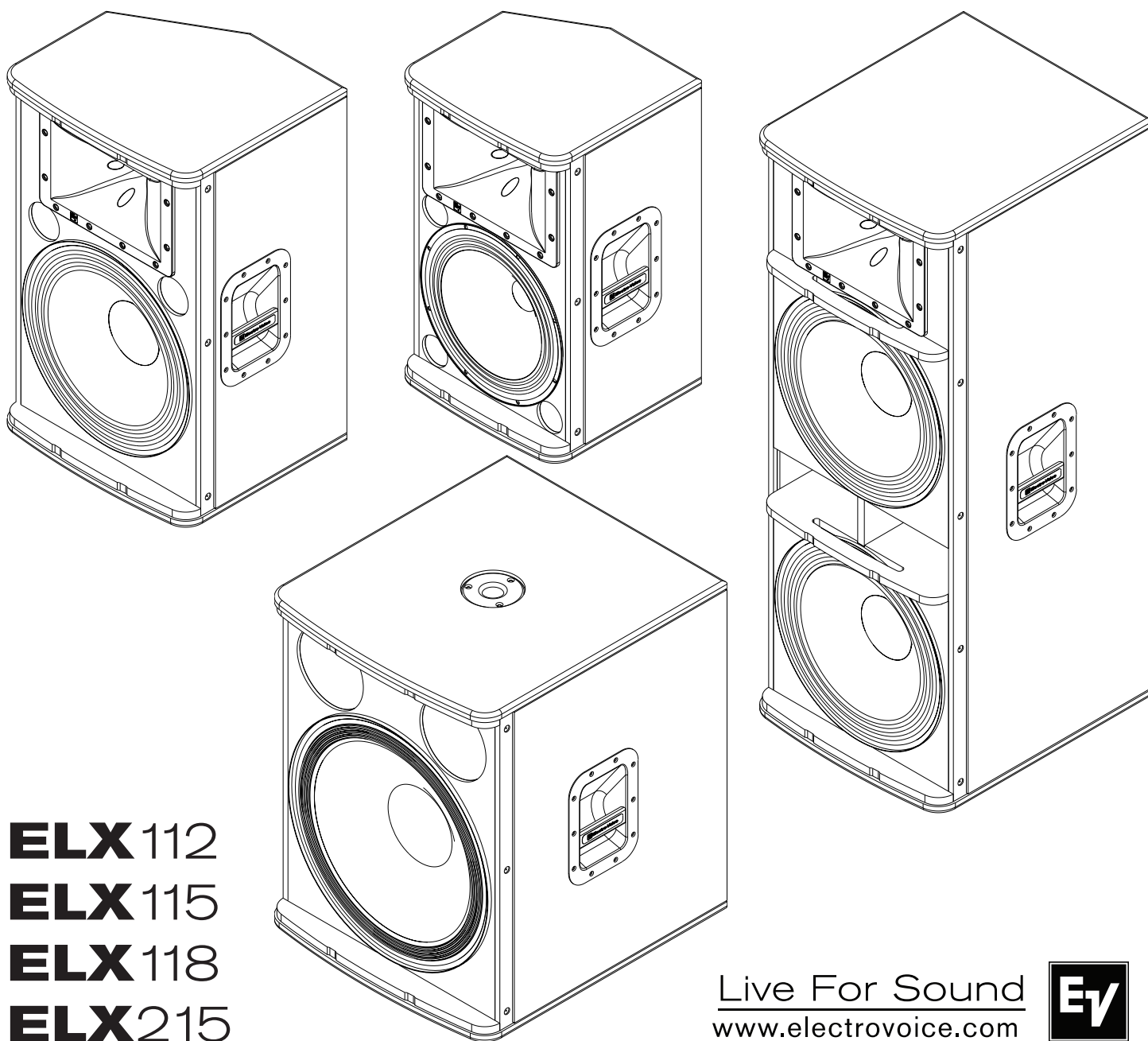

ELX 112
ELX 115
ELX 118
ELX 215

Live For Sound
www.electrovoice.com



Important Safety Instructions

1. Read these instructions.
2. Keep these instructions.
3. Heed all warnings.
4. Follow all instructions.
5. Do not use this apparatus near water.
6. Clean only with a dry cloth.
7. Do not install near any heat sources such as radiators, heat registers, stoves, or other apparatus (including amplifiers) that produce heat.
8. Only use attachments/accessories specified by the manufacturer.
9. Do not expose this apparatus to dripping or splashing and ensure that no objects filled with liquids, such as vases, are placed on this apparatus.



The lightning flash with arrowhead symbol, within an equilateral triangle is intended to alert the user to the presence of uninsulated “dangerous voltage” within the product’s enclosure that may be of sufficient magnitude to constitute a risk of electric shock to persons.



The exclamation point within an equilateral triangle is intended to alert the user to the presence of important operating and maintenance (servicing) instructions in the literature accompanying the appliance.



The asterisk within an equilateral triangle is intended to inform the user to necessary installation or removal instructions regarding equipment or hardware use relating to the system.



Management of WEEE (waste electrical and electronic equipment) (applicable in Member States of the European Union and other European countries with individual national policies on the management of WEEE) The symbol on the product or on its packaging indicates that this product may not be treated as regular household waste, but has to be disposed through returning it at an Electro-Voice dealer.

Precautions



- Do not use Live X loudspeakers in an environment where temperatures exceed +40°C (104°F).



- Never expose a Live X loudspeaker to rain, water, or high moisture.



- Electro-Voice Live X loudspeakers are easily capable of generating sound pressure levels sufficient to cause permanent hearing damage to anyone within normal coverage distance. Caution should be taken to avoid prolonged exposure to sound pressure levels exceeding 90 dB.

Table of Contents

Important Safety Instructions	2
Precautions	2
Description	3
System Features	3
Tripod and Floor Monitor Operation	5
Recommended Configurations.....	7
Specifications	11
Dimensions.....	12
Frequency Response Graphs.....	14
Live X Model Reference Table	14
Warranty Information.....	14
Troubleshooting.....	15



Description

Thank you for choosing an Electro-Voice Live X passive loudspeaker system. Please take time to consult this manual to understand all the features built into your Electro-Voice system and fully utilize its performance capabilities.

Clear, powerful and musical Electro-Voice loudspeakers command the stage at high-profile venues and major events worldwide. Born stage-ready, the Live X series includes powered and passive models that all feature EV-engineered components in solid wood cabinets. Wherever performance matters, Live X is serious gear for serious sound.

System Features

ELX112 – 12" Two-Way Passive Loudspeaker

The versatile ELX112 loudspeaker is a compact, powerful choice with real stage presence, for sound reinforcement and stage monitoring applications.

- DH-1K 39mm (1.5") Titanium Diaphragm Compression Driver
- EVS-12K 305mm (12") Woofer
- 55 Hz – 20 kHz frequency range
- 94 dB SPL sensitivity; 132 dB max SPL
- 250 W continuous and 1000 W peak power handling
- Pole-mounts or stacks with Live X Subwoofers
- High Frequency Waveguide with 90° x 50° Coverage Pattern
- 60° Monitor Angle
- 15mm Plywood Enclosure, Internally Braced, with Textured Paint

ELX115 – 15" Two-Way Passive Loudspeaker

A powerful step up from the ELX112, the ELX115 features a 15" woofer that delivers extended low-frequency response for bigger sound in larger rooms.

- DH-1K 39mm (1.5") Titanium Diaphragm Compression Driver
- EVS-15K 381mm (15") Woofer
- 50 Hz – 20 kHz frequency range
- 95 dB SPL sensitivity; 134 dB max SPL
- 400 W continuous and 1600 W peak power handling
- Pole-mounts or stacks with Live X Subwoofers
- High Frequency Waveguide with 90° x 50° Coverage Pattern
- 60° Monitor Angle
- 15mm Plywood Enclosure, Internally Braced, with Textured Paint

System Features (cont')

ELX215 – Dual 15" Two-Way Loudspeaker

This twin woofer configuration delivers real low-end punch — ideal for applications that demand high-volume output and an ultra-wide frequency response from a single cabinet.

- DH-1K 39mm (1.5") Titanium Diaphragm Compression Driver
- Dual EVS-15K 381mm (15") Woofers
- 38 Hz – 20 kHz frequency range
- 96 dB SPL sensitivity; 137 dB max SPL
- 600 W continuous and 2400 W peak power handling
- High Frequency Waveguide with 90° x 50° Coverage Pattern
- 15mm Plywood Enclosure, Internally Braced, with Textured Paint

ELX118 – 18" Passive Subwoofer

Optimized for performance with the ELX112 and ELX115, the ELX118 adds a full, deep, low-frequency punch that you can hear and feel.

- EVS-18K 457mm (18") Woofer provides extended low-frequency output
- 35 Hz – 200 Hz frequency range
- 96 dB SPL sensitivity; 134 dB max SPL
- 400 W continuous and 1600 W peak power handling
- Supports pole-mounted or stacked Live X Loudspeakers
- 15mm Plywood Enclosure, Internally Braced, with Textured Paint

Tripod and Floor Monitor Operation

Floor Monitor

Electro-Voice ELX112 and ELX115 loudspeakers may be used as a floor monitor by placing the speaker on the integral monitor angle. Make sure to:

- Place the speaker on a level, stable surface that is solid and secure.
- Route cables so that performers, production crew and audience members will not trip over the cables. Secure cables with wire ties or tape whenever possible.

See Figures 1a and 1b for optimal coverage areas in front of the loudspeaker when in monitor position.

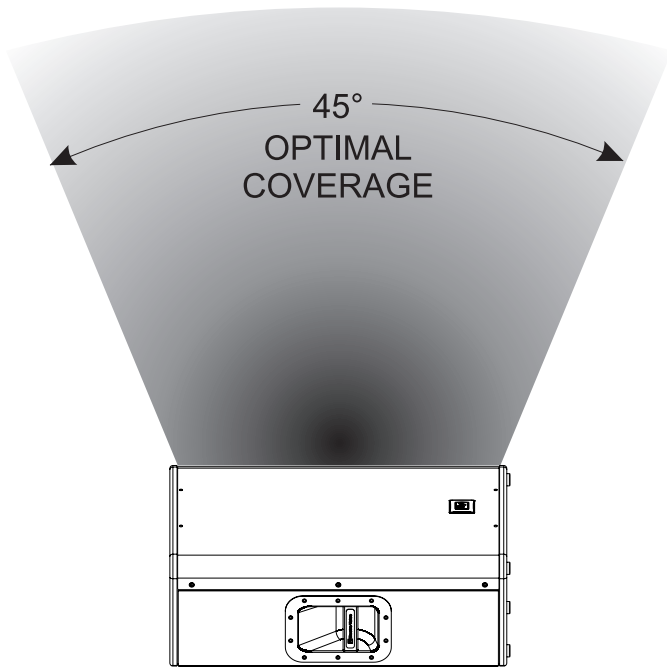

Figure 1a:
ELX112 / ELX115 Optimum Coverage
(Front View)

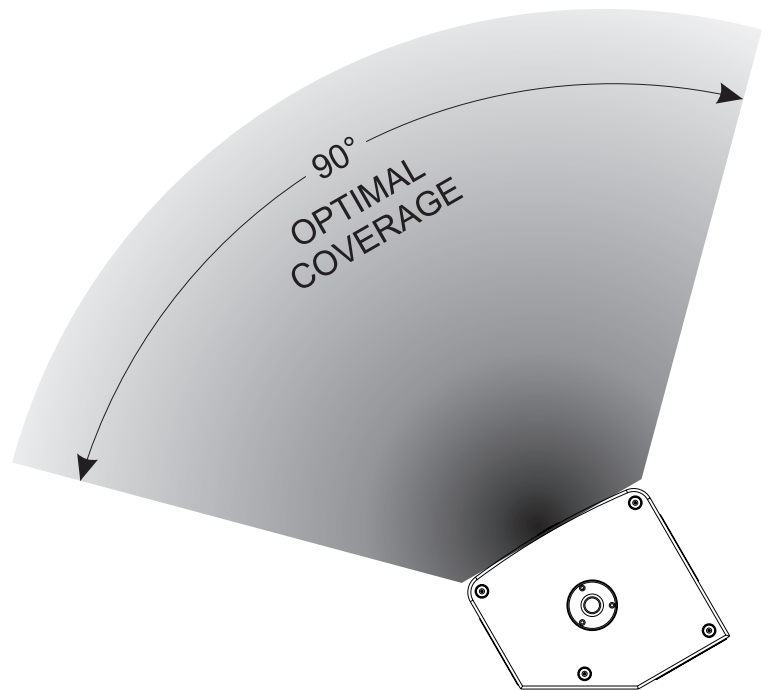

Figure 1b:
ELX112 / ELX115 Optimum Coverage
(Side View)

Tripod and Floor Monitor Operation

Tripod

Electro-Voice ELX112 and ELX115 loudspeakers include 35mm (1-3/8") stand mounts to allow mounting on tripod stands or above an ELX118. Make sure to:

- Check the specifications of the speaker stand to be certain it is capable of supporting the weight of the speaker.
- Check that the speaker stand is placed on a flat, stable surface and be sure to fully extend the legs of the stand. Do not try to make the stand "taller" and compromise its structural integrity.
- Route cables and position the stand so that performers, production crew and audience members will not trip over the stand or cables and pull the speaker system over. Secure cables with wire ties or tape whenever possible.
- Do not attempt to suspend more than one speaker on a stand designed for a single speaker.
- Unless you are confident that you can safely handle lifting the weight of the speaker onto the stand, ask another person to help you place it.

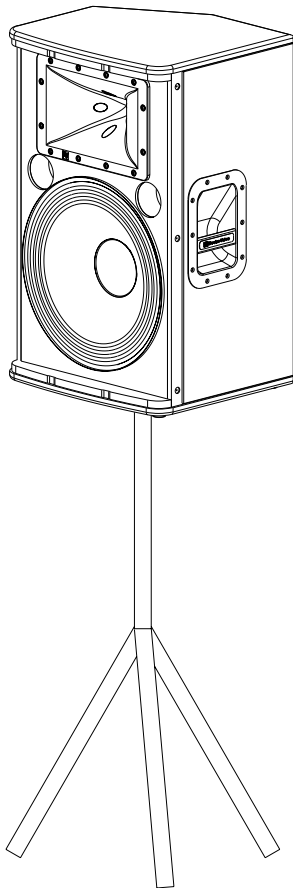

Figure 2a:
ELX112 / ELX115 on Tripod Stand

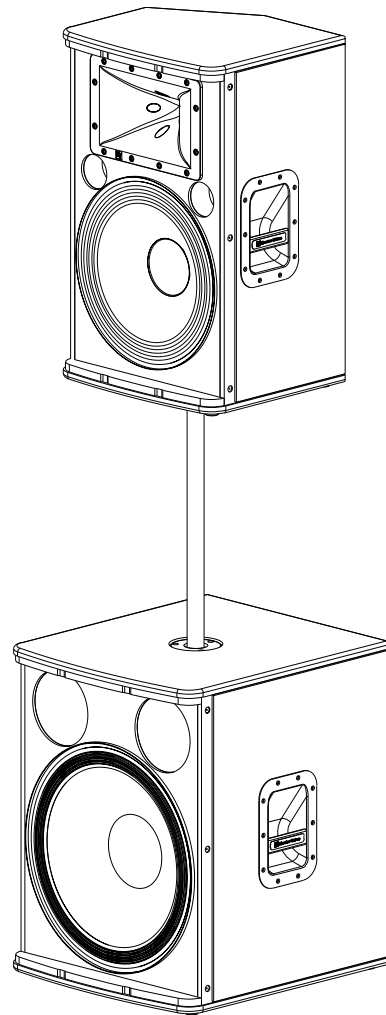

Figure 2b:
Live X Full-Range/Sub Stack with Pole Mount

Recommended Configurations

Basic Stereo System using ELX112's or ELX115's

NL4 Pin Configuration	
Pins 1+ and 1-	Used
Pins 2+ and 2-	Not Used

Amplifier Load (per Output Channel)		
# of Speakers	Nominal	Minimum
1	8 Ohms	7 Ohms
2	4 Ohms	3.5 Ohms
3	2.7 Ohms	2.3 Ohms
4	2 Ohms	1.8 Ohms
	Caution: Do not exceed the maximum load rating of the amplifier.	

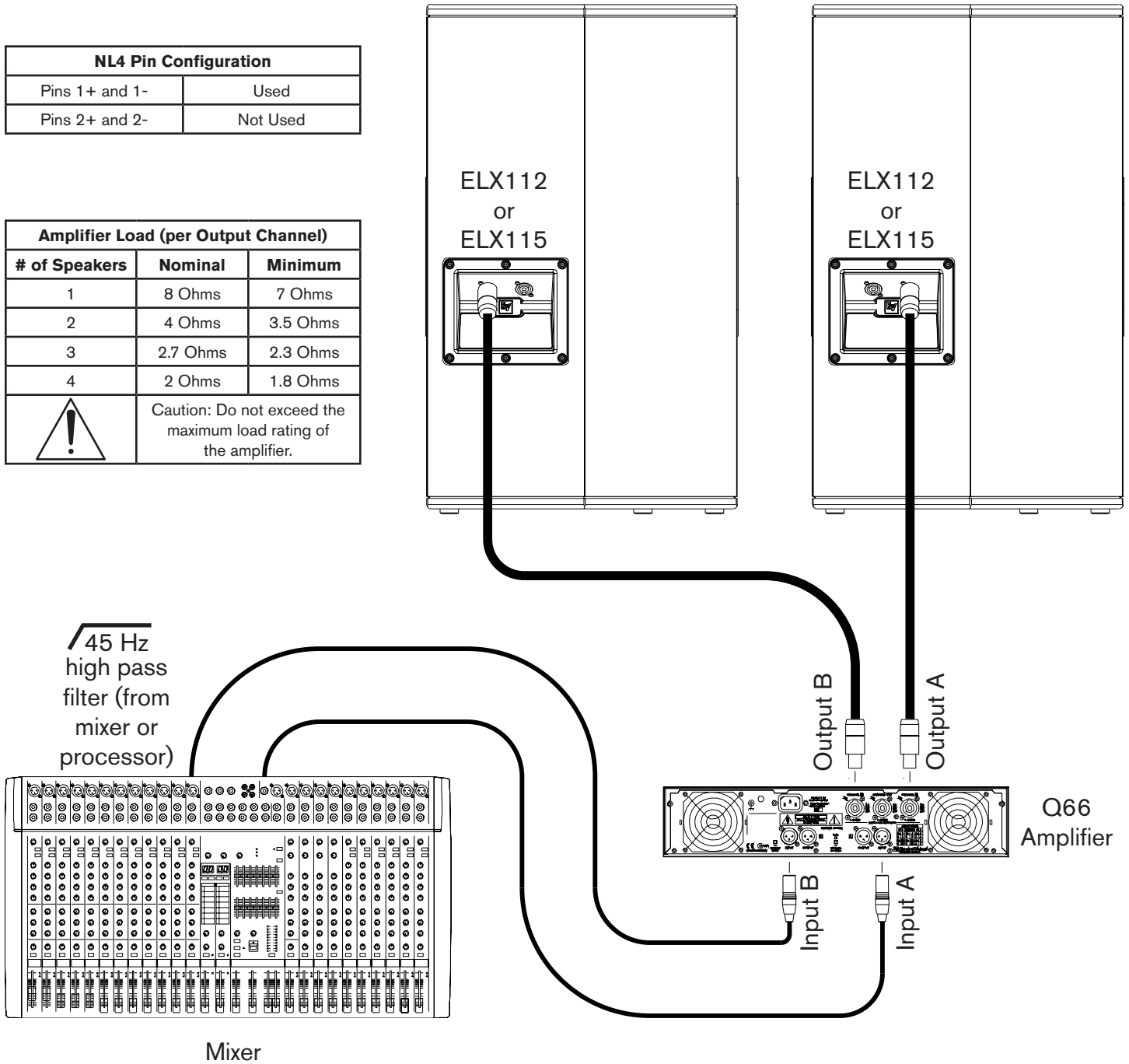

Recommended Configurations (cont')

Linking ELX118 subwoofers to ELX112's or ELX115's

This configuration allows a user to increase the low frequency performance without using additional amplifier channels.

NL4 Pin Configuration	
Pins 1+ and 1-	Used
Pins 2+ and 2-	Not Used

Amplifier Load (per Output Channel)		
# of Subwoofer/ Full-Range Combinations	Nominal	Minimum
1	6 Ohms	4.2 Ohms
2	3 Ohms	2.1 Ohms
	Caution: Do not exceed the maximum load rating of the amplifier.	

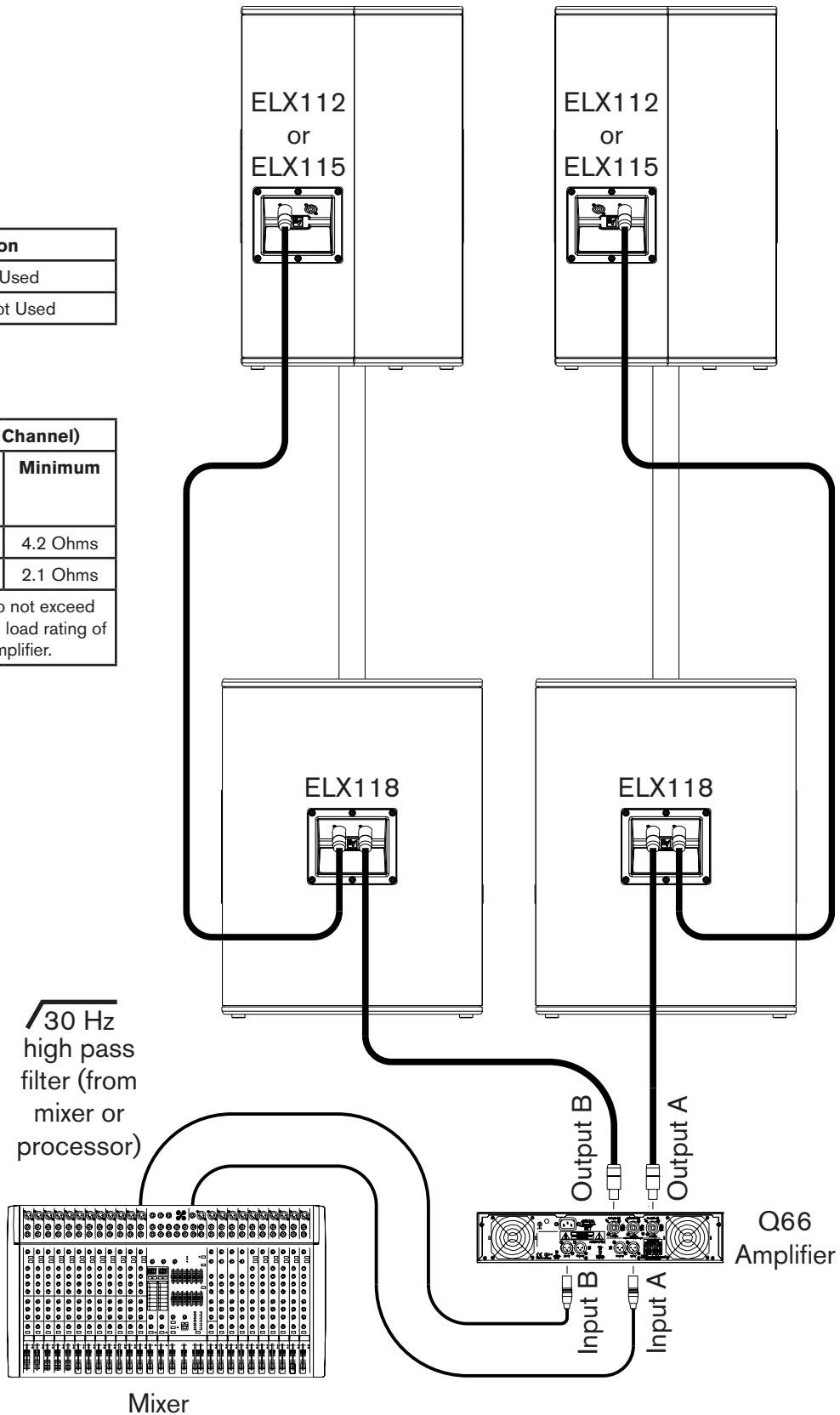

Recommended Configurations (cont')

Basic Stereo System using ELX215's

NL4 Pin Configuration	
Pins 1+ and 1-	Used
Pins 2+ and 2-	Not Used

Amplifier Load (per Output Channel)		
# of Speakers	Nominal	Minimum
1	4 Ohms	3.7 Ohms
2	2 Ohms	1.9 Ohms
 Caution: Do not exceed the maximum load rating of the amplifier.		

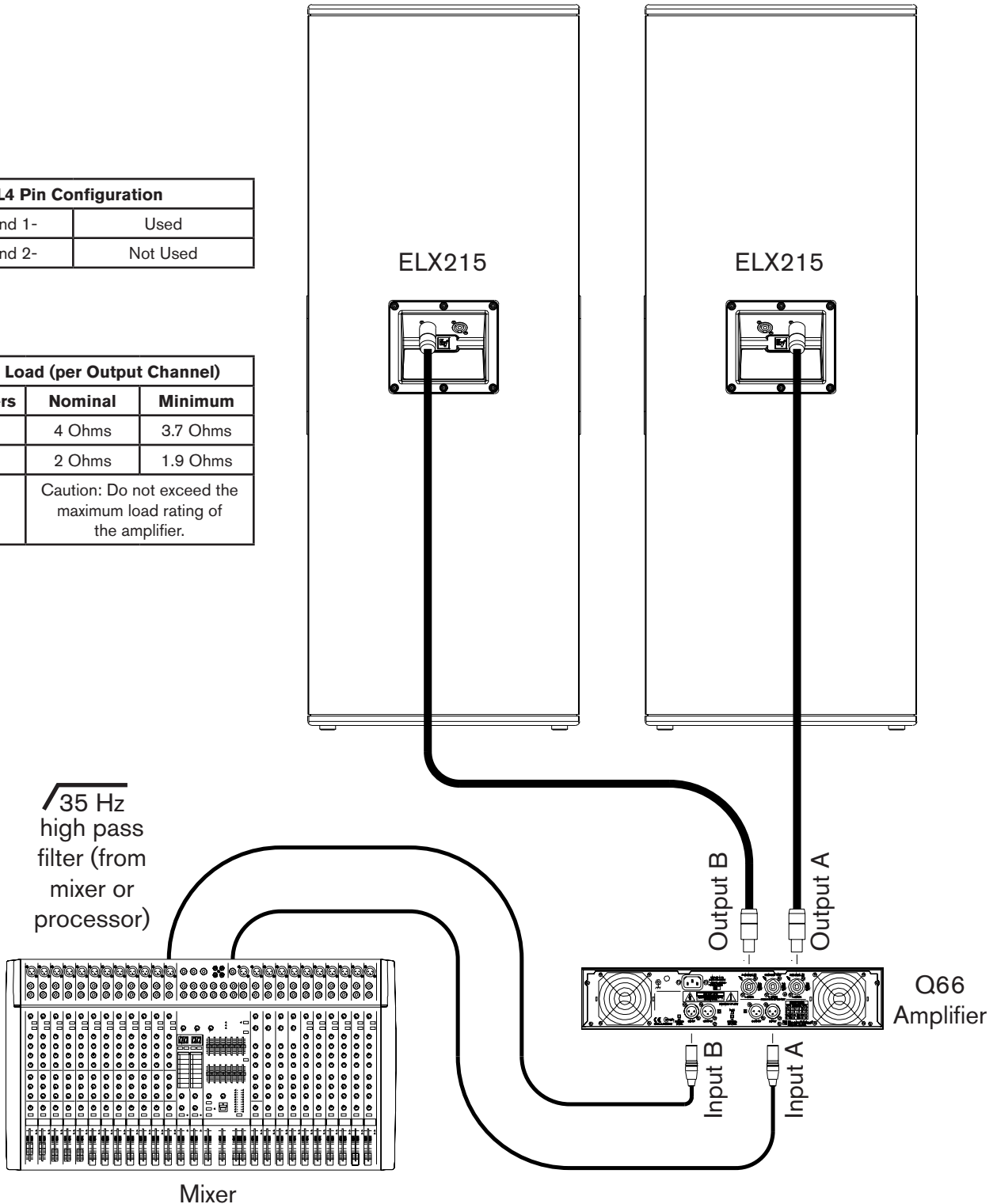

Recommended Configurations (cont')

Using multiple ELX112's or ELX115's as stage monitors

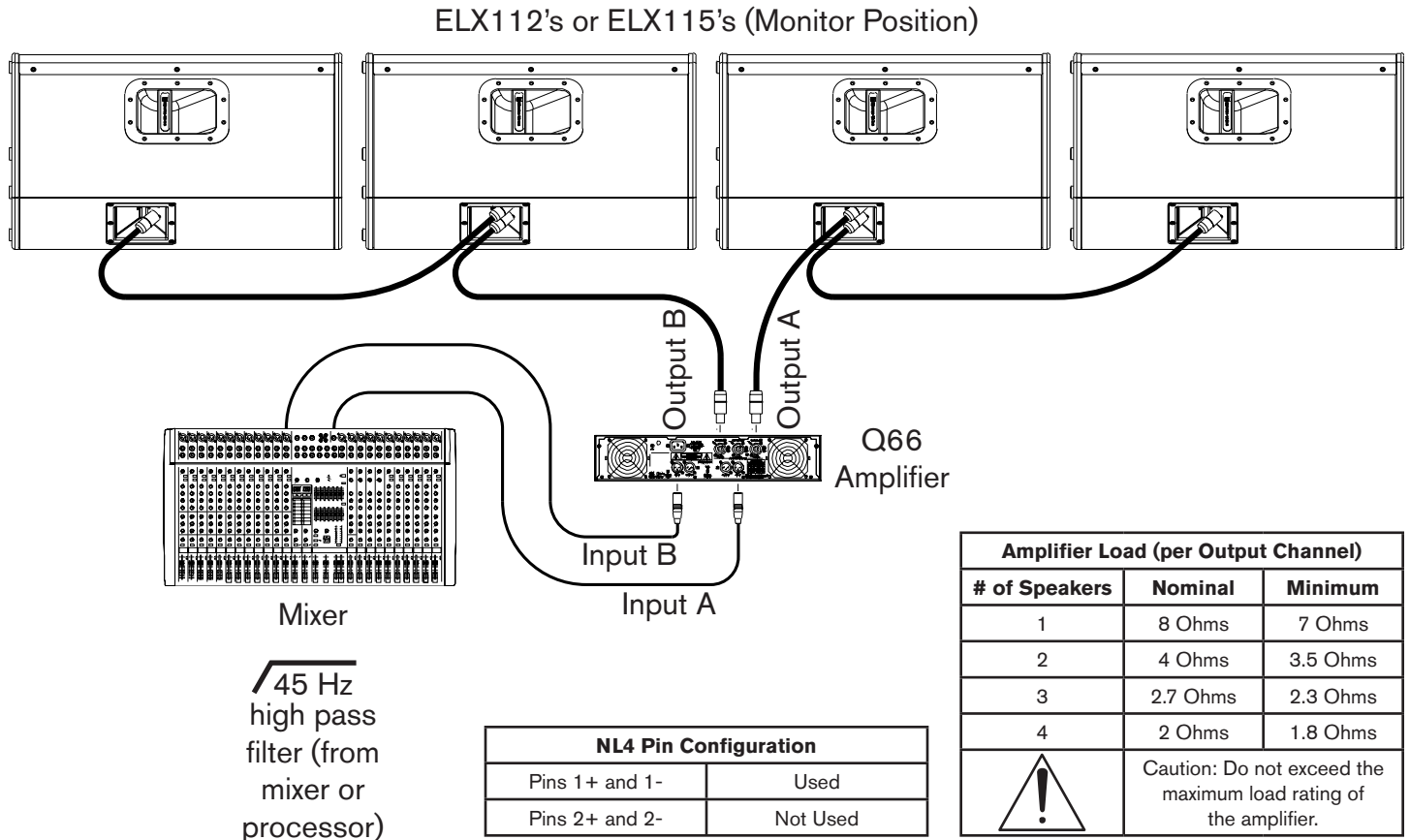

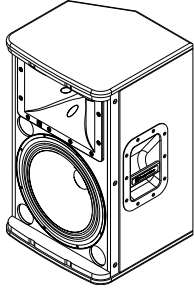
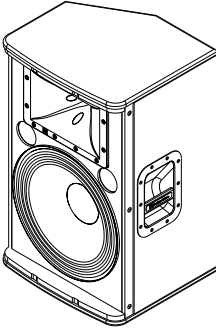
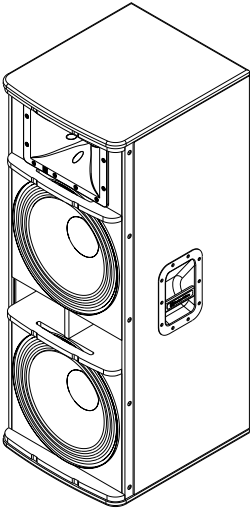
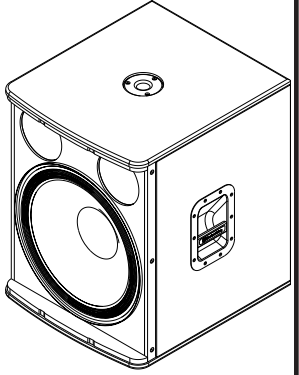

Specifications

Model (Part Number)	ELX 112 (F01U170823)	ELX 115 (F01U170824)	ELX 215 (F01U170826)	ELX 118 (F01U170825)
				
Freq. Response (-3 dB):	82 Hz - 18 kHz ¹	75 Hz - 18 kHz ¹	62 Hz - 18 kHz ¹	50 Hz - 100 Hz ²
Freq. Range (-10 dB):	55 Hz - 20 kHz ¹	50 Hz - 20 kHz ¹	38 Hz - 20 kHz ¹	35 Hz - 200 Hz ²
Axial Sensitivity:	94 dB	95 dB	96 dB	96 dB
Max. Measured SPL ³ :	132 dB	134 dB	137 dB	134 dB
Recommended HP Freq.:	45 Hz	40 Hz	35 Hz	30 Hz
Coverage (Horiz. x Vert.):	90° x 50°			Omnidirectional
Power Handling:	250W Continuous, 1000W Peak	400W Continuous, 1600W Peak	600W Continuous, 2400W Peak	400W Continuous, 1600W Peak
LF Transducer(s):	(1) EVS-12K, 305mm (12") Woofer	(1) EVS-15K, 381mm (15") Woofer	(2) EVS-15K, 381mm (15") Woofers	(1) EVS-18K, 457mm (18") Woofer
HF Transducer:	DH-1K, 39mm (1.5") Titanium Diaphragm Compression Driver			N/A
Crossover Frequency:	2.1 kHz	1.7 kHz		N/A
Nominal Impedance:	8 Ohms		4 Ohms	8 Ohms
Minimum Impedance:	7.0 Ohms	7.4 Ohms	3.7 Ohms	6.7 Ohms
Connectors:	Dual NL4			
Enclosure Material:	9-ply, 15mm Plywood, Internally Braced, with Textured Paint			
Grille:	18GA Steel with Black Powdercoat			
Dimensions (H x W x D):	607mm x 362mm x 340mm (23.89" x 14.25" x 13.41")	708mm x 432mm x 382mm (27.89" x 17.02" x 15.05")	1154mm x 432mm x 501mm (45.44" x 17.02" x 19.73")	661mm x 507mm x 574mm (26.02" x 19.98" x 22.60")
Net Weight:	16.0 kg (35.2 lbs)	21.9 kg (48.2 lbs)	40.7 kg (89.6 lbs)	30.6 kg (67.4 lbs)
Shipping Weight:	19.9 kg (43.8 lbs)	26.6 kg (58.6 lbs)	48.4 kg (106.6 lbs)	37.2 kg (81.9 lbs)
Accessories:	TSS-1, Aluminum Tripod Stand TSP-1, Tripod Kit, Includes (2) Tripod Stands and Carrying Case ASP-1, Steel Subwoofer Stand		N/A	ASP-1, Steel Subwoofer Stand

¹ Full Space Measurement

² Half Space Measurement

³ Max SPL is measured at 1m using broadband pink noise at rated peak power rating.

Live X

Dimensions

ELX112

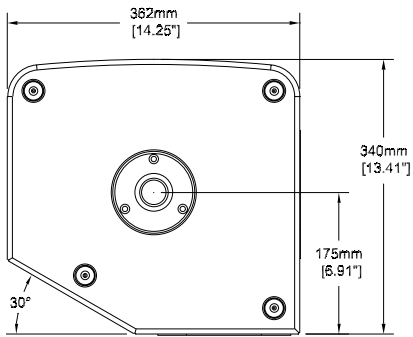

Bottom View

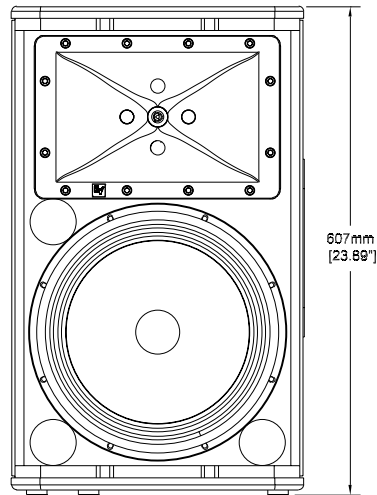

Front View

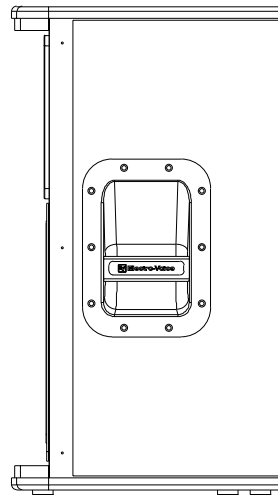

Right View

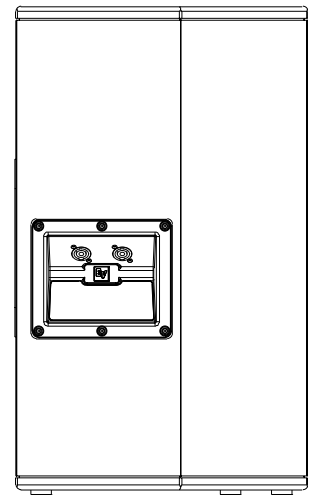

Rear View

ELX115

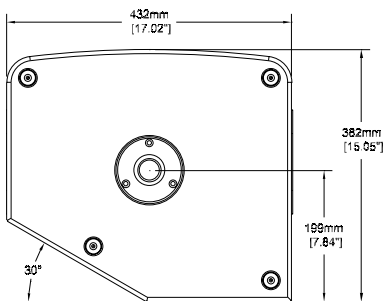

Bottom View

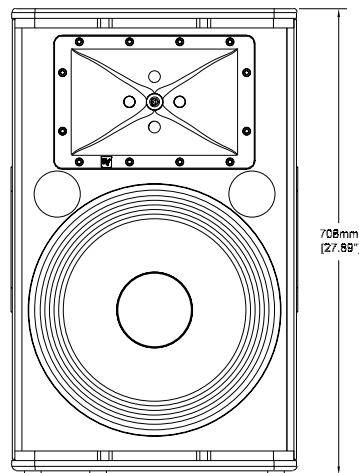

Front View

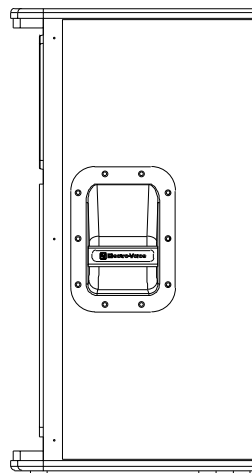

Right View

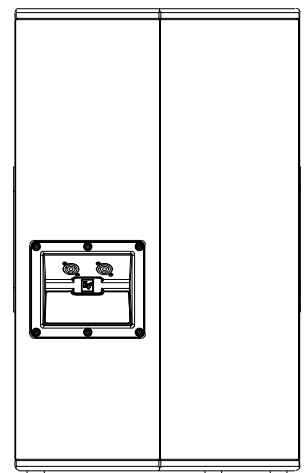

Rear View

Dimensions (cont')

ELX118

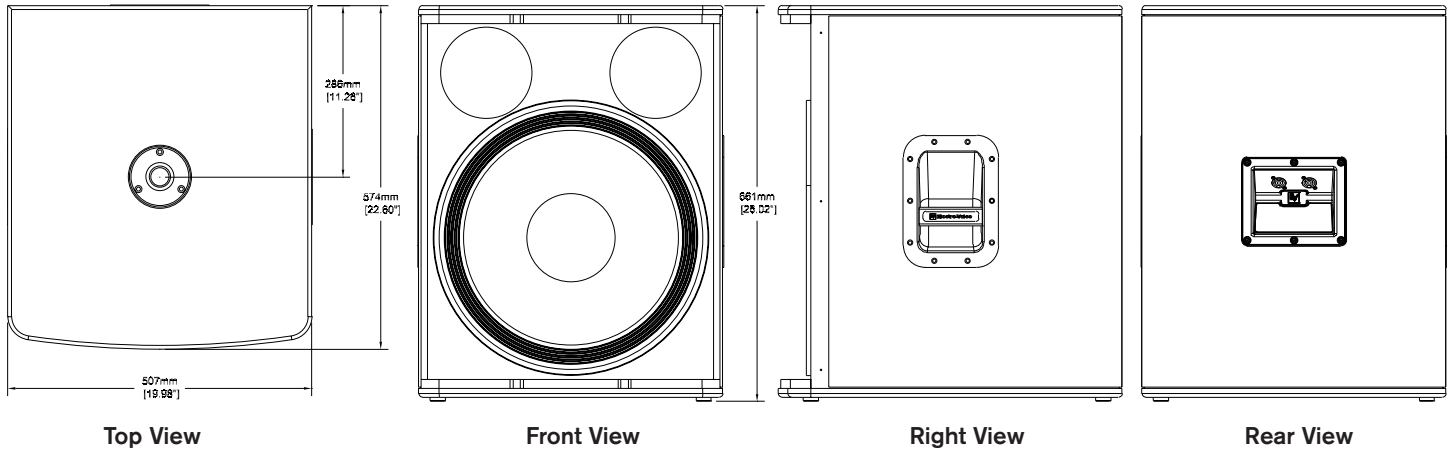

ELX215

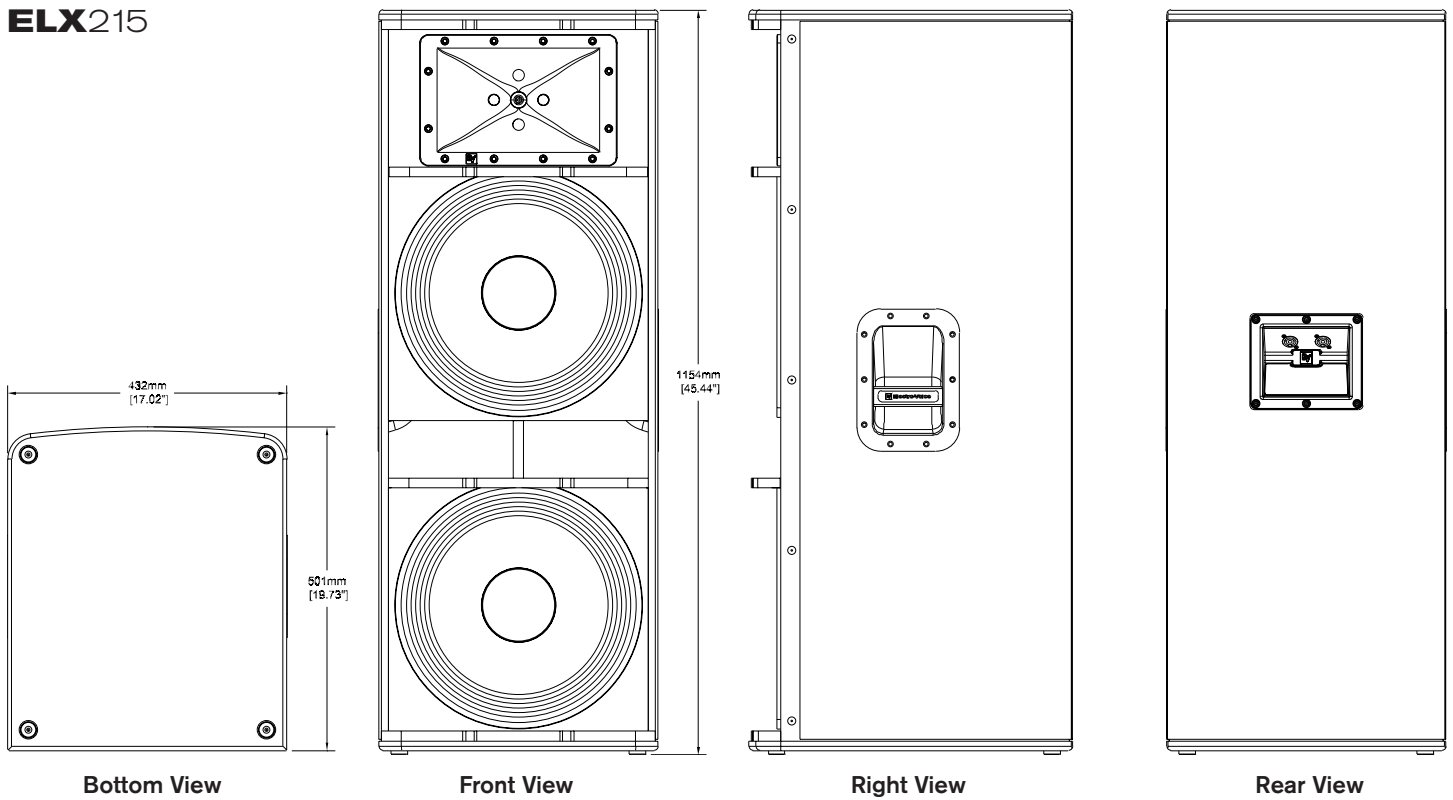

Frequency Response Graphs

ELX112

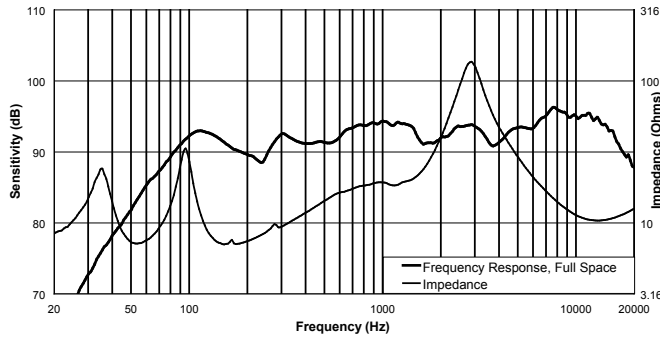

ELX115

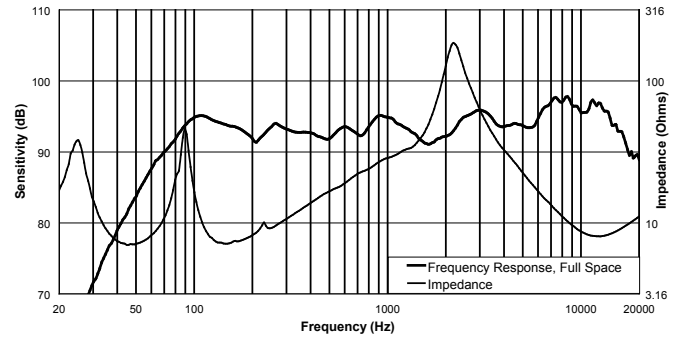

ELX118

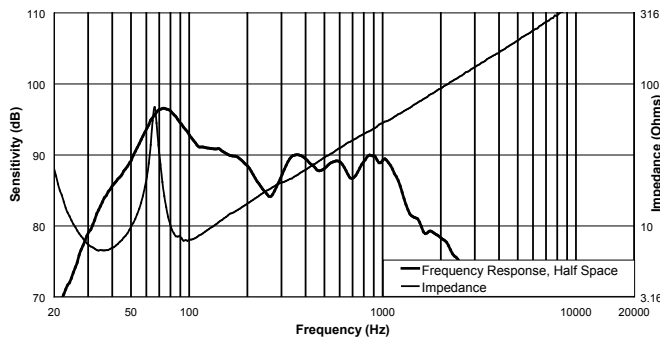

ELX215

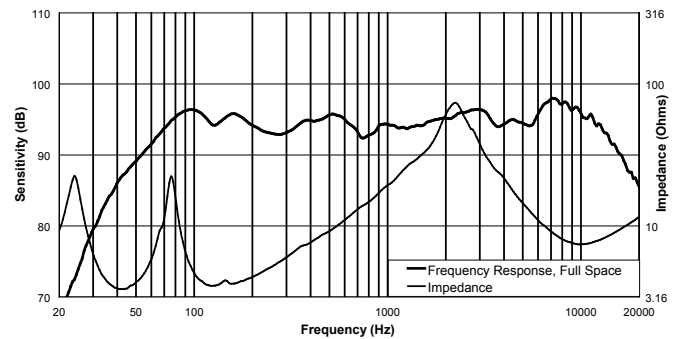

Live X Model Reference Table

System Model	Coverage	Finish	Part No.
ELX112	90° x 50°	Black	F01U170823
ELX115	90° x 50°	Black	F01U170824
ELX118	Omnidirectional	Black	F01U170825
ELX215	90° x 50°	Black	F01U170826

Warranty Information

Visit www.electrovoice.com/warranty for warranty information.



Troubleshooting

Problem	Possible Cause(s)	Action
1. No Sound	Amplifier	Connect a known working test speaker to the amplifier outputs. If there is no sound, check that all the electronics are on, the signal routing is correct, the source is active, the volume is turned up, and so on. Correct/repair/replace as necessary. If there is sound, the problem is in the wiring.
	Wiring	Verify that you have connected the correct wire pairs to the amplifier. Play something at low level through the amplifier (for example, from a CD player or tuner). Connect the test speaker in parallel with the malfunctioning line. If the sound level has gone or is very weak, the line has a short in it (possibly a severe scrape, pinch, or staple puncture). If the sound level is normal, the wire is open (possibly a cut wire or a missed connection). Using the test speaker, move down the line and test each connection/junction until you find the problem and correct it. Observe proper polarity.
2. Poor Low Frequency Response	Speakers wired out-of-polarity	When two speakers are connected out of polarity, the low frequencies will cancel each other acoustically. Carefully observe the wire markings or tracers on your speaker wires. Verify that the amplifier (+) terminal is connected to pin 1+ of the NL4 connector and the amplifier (-) terminal is connected to pin 1- of the NL4 connector.
3. Intermittent output such as crackling or distortion	Faulty Connection	Check all connections at amplifier and speakers to ensure they are all clean and tight. If the problem persists, it may be in the amplifier or wiring. See Problem 1 above.
4. Constant noise such as buzzing, hissing, humming	Defective amplifier or other electronic device	If the noise is present but no program material is playing, the likely cause is the signal chain in the electronics. Evaluate each component as necessary to isolate the problem.
	Poor system grounding or ground loop	Check and correct the system grounding, as required.
If these suggestions do not solve your problem, contact your nearest Electro-Voice dealer or Electro-Voice distributor.		

Electro-Voice

12000 Portland Avenue South, Burnsville, MN 55337
Phone: 952/884-4051, Fax: 952/884-0043

www.electrovoice.com

© Bosch Communications Systems 06/2011
Part Number LIT000504 Rev 3

U.S.A. and Canada only. For customer orders, contact Customer Service at:
800/392-3497 Fax: 800/955-6831
Europe, Africa, and Middle East only. For customer orders, contact Customer Service at:
+ 49 9421-706 0 Fax: + 49 9421-706 265
Other International locations. For customer orders, Contact Customer Service at:
+ 1 952 884-4051 Fax: + 1 952 887-9212
For warranty repair or service information, contact the Service Repair department at:
800/685-2606
For technical assistance, contact Technical Support at: **866/78AUDIO**

Specifications subject to change without notice.