



### EMX-AMP

HDMI Audio Extractor with 50 Watt Audio Amplifier, Line Audio Input, RS-232 Ports

### EMX-I-AMP

HDMI Audio Extractor with 50 Watt Audio Amplifier, Line Audio Input, RS-232 Ports and IP Control (Telnet & Internal Web GUI)



# Table of Contents

<b>1.0 INTRODUCTION</b> .....	<b>4</b>
<b>2.0 FEATURES</b> .....	<b>5</b>
2.1 PACKAGE CONTENTS.....	5
<b>3.0 SETUP</b> .....	<b>6</b>
3.1 INSTALLATION .....	6
<b>4.0 OPERATION</b> .....	<b>7</b>
4.1 FRONT PANEL .....	7
4.2 REAR PANEL.....	9
4.3 FACTORY DEFAULT .....	11
4.4 POWER CONNECTION .....	11
4.5 LINE IN CONNECTION .....	12
4.6 L/R SPEAKER CONNECTIONS .....	12
<b>5.0 WEBGUI AND TELNET OPERATION</b> .....	<b>13</b>
5.1 AMP POWER .....	13
5.2 AUDIO MIX .....	13
5.3 VOLUME CONTROL.....	13
5.4 EXTERNAL DEVICE CONTROL .....	13
5.5 LOCATING THE DEVICE ON A LAN.....	14
5.6 TELNET.....	14
<b>6.0 SENSE FUNCTION</b> .....	<b>14</b>
6.1 PAGE SENSOR.....	14
6.2 PAGE SENSOR INSTALLATION .....	15
6.3 PAGE MUTE ON CONTACT CLOSURE.....	15
<b>7.0 DUCKING FUNCTION</b> .....	<b>15</b>
<b>8.0 MONO OUTPUT MIX</b> .....	<b>15</b>
<b>9.0 SERIAL COMMANDS</b> .....	<b>16</b>
9.1 SERIAL CONNECTIONS.....	16
9.2 AUTOMATIC POWER CONTROL OF DISPLAY BASED ON HDMI INPUT DETECTION.....	20
9.3 DEVICE ADDRESSING FOR SPECIAL DAISY-CHAIN OPERATION.....	20
<b>10.0 TROUBLESHOOTING</b> .....	<b>21</b>
<b>11.0 SPECIFICATIONS</b> .....	<b>22</b>

## TRADEMARKS USED IN THIS MANUAL

Hall Research and its logo **HR** are trademarks of Hall Research. Any other trademarks mentioned in this manual are acknowledged as the property of the trademark owners.

## FCC RADIO FREQUENCY INTERFERENCE STATEMENT

This device complies with part 15 of the FCC Rules. Operation is subject to the following two conditions:

1. This device may not cause harmful interference, and
2. This device must accept any interference received, including interference that may cause undesired operation



## 1.0 Introduction

The EMX-AMP is a 4K HDMI Audio Extractor with built-in 50 watt audio amplifier for direct connection of 8 ohm speakers. It provides an additional line-level stereo audio input that can be mixed with the HDMI audio. Volume can be controlled using front panel buttons, RS-232 commands, or via an external rotary digital encoder.

The EMX-AMP provides an independent RS-232 output port that can be used to control other devices. Typically it is used to control the power on/off state of the TV or video projector connected to its output.

Full EDID management is provided with the ability to learn, download, upload, emulate or pass-thru the EDID from the connected display. A USB port is featured on the front panel that can be used to configure the device operation via a free Windows™ GUI available from <http://www.hallresearch.com>.

The EMX-AMP can pass commands from its RS-232 input to the RS-232 output. It also has the ability to store user defined ON and OFF commands for controlling devices connected to its RS-232 output (e.g. to control power on/off function of display).

The stored RS-232 commands can be triggered automatically (based on detecting HDMI input) or manually by user command (RS-232, Telnet, WebGUI), or contact closure.

An IP enabled version is available (**EMX-I-AMP**) adds a Telnet and WebGUI. This gives the user the ability to control the device through a PC or Smartphone. Telnet control uses the same commands as the serial interface.

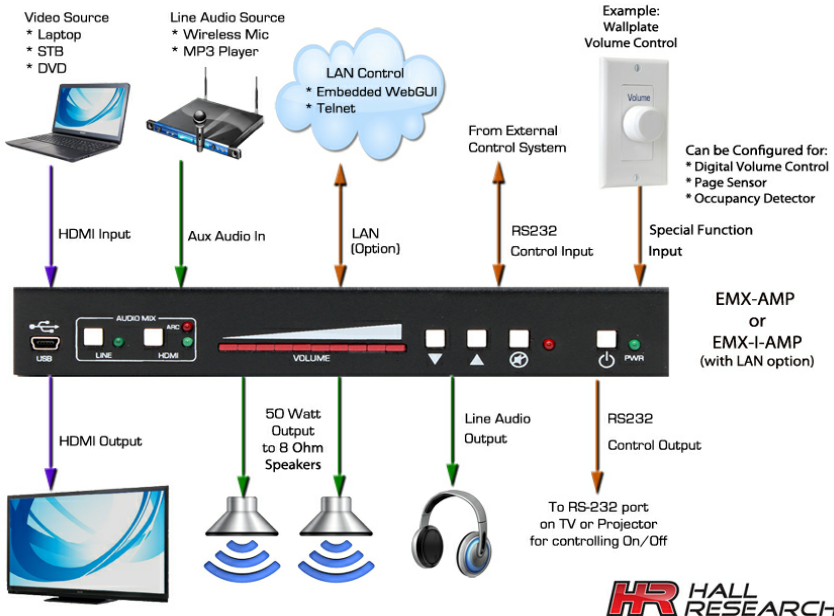

Figure 1 – Connection Diagram

## 2.0 Features

- 4K HDMI audio extractor with EDID management
- Built-in 50 watt amplifier for connection to 8 Ohm speakers (25 watts/channel)
- Audio input for connecting line-level audio inputs (e.g. wireless microphones).
- Control via, front panel, RS-232, digital pot (rotary encoder), Webpage or Telnet
- HDMI Ducking (when Line input is detected, HDMI sound volume in the mix is automatically lowered)
- Primary RS-232 port for device control
- Secondary RS-232 port for auxiliary device control
- Store separate ON/OFF RS-232 commands for the auxiliary devices
- Supports HDMI, DVI, HDCP, 3D and Deep color
- Stereo or Mono output
- Priority Paging Sensor input (for automatically muting of the audio output)
- Compact, Rugged, Reliable, and Economical
- Made in the USA

## 2.1 Package Contents

Qty (1) EMX-AMP

Qty (1) 18V DC Universal DC Power Adapter

Qty (1) User's Manual

Qty (1) Type A to Mini-B USB cable

Qty (1) 4 Position Screw Terminal Strip

Qty (1) 9 Position Screw Terminal Strip

### 3.0 Setup

#### 3.1 Installation

- Connect an HDMI compatible source signal to the HDMI IN connector.
- Connect the HDMI display device to the HDMI OUT connector. Note that even if the HDMI output is disconnected, the EMX-AMP extracts video from the HDMI source.
- Connect a pair of 8 ohm loudspeakers to the speaker output screw terminals. For connecting more than 2 speakers, please see Section [4.6](#).
- **Optionally**, connect a compatible line-level audio source to the LINE IN connector. (e.g., wireless microphone or MP3 player). See sections [4.2](#) and [4.5](#) for more information on the Line In connector.
- **Optionally**, connect a compatible line-level audio output device to the LINE OUT connector. (e.g., headphones, assistive listening devices). The Line out signal volume is variable and is set by adjusting output volume
- **Optionally**, connect a compatible RS-232 control device to the RS-232 IN 3-pin terminal connector. (e.g., Serial Controller)
- **Optionally**, connect the compatible RS-232 device to be controlled to the RS-232 OUT 3-pin terminal connector. (e.g., Projector or LCD)
- **Optionally**, if the device is EMX-I-AMP, connect it to your LAN using a CAT5e/6 cable plugged to the LAN connector.
- **Optionally**, connect one of the following functions to the 3 configurable pins on the screw terminal. The function of these pins can be set by the user via the free Windows GUI available on product's website. By default the pins are configured to connection of external rotary volume knob. The following operation modes are available
  - External digital rotary encoder (for volume control using a knob) -*Default*
  - Priority Page Sensor (for detecting page announcement)
  - Occupancy Detector (to trigger the unit to send out Power On/Off commands to the display).

See section [4.2](#) for details.

## 4.0 Operation

The following is a functional block diagram of the audio routing in the EMX-AMP:

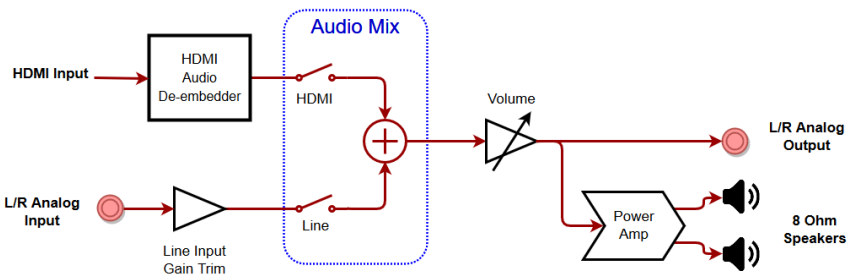

Figure 2 – Audio Routing and Processing Diagram

## 4.1 Front Panel



Figure 3 - Front Panel

### PWR

Press this button to turn the unit on and off. When the unit is ON, the LED glows.

### MUTE

Press this button to mute the output audio. When the unit is muted, the LED glows.

### ▲ & ▼

Press these buttons to increase or decrease the output volume. Volume can be adjusted regardless of mute status. If volume is changed when the output is muted, it will be at the new level when un-muted.

### NOTE

*Volume setting affects both the Speaker output as well as the 3.5mm stereo output. The volume of the audio embedded in the HDMI output is not affected.*

### LED Volume Bar

The illuminated LEDs show the current audio setting 0 to 100%. The level is adjusted using the ▲ & ▼ buttons.

## Audio Mix Buttons

The LINE and HDMI buttons are used to select audio inputs. When both are selected, the audio from each source are added together.

### LINE

Press this button to select the Line input and add it to the output audio. When the Line input is selected, the LED glows.

### HDMI

Press this button to select the audio embedded in the HDMI input and add it to the output audio. When the HDMI input is selected, the LED glows.

### NOTE

*If nothing is connected to the 3.5mm audio input, it is recommended to unselect the LINE in the audio mix. This eliminates any possible residual noise picked up by the analog circuits connected to the unused LINE input*

## Using the HDMI ARC audio

Instead of using the audio from the HDMI input, the user can use the audio signal returning from the TV connected to the output (TV must support ARC function). To reassign the HDMI audio from INPUT to ARC, use the free Windows GUI available for free download on the product's website.

When configured to use the ARC function, selecting the HDMI button on the front panel lights both HDMI and ARC LEDs at the same time. This indicates the ARC pin in the HDMI is being selected.

## USB

Connect the supplied USB cable to a compatible Windows™ PC using for use with the Software GUI available for download from <http://www.hallresearch.com>.

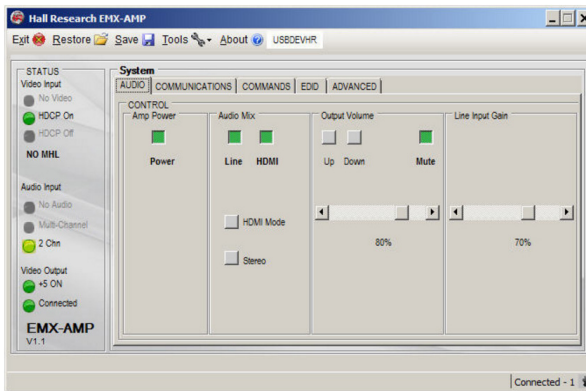

Figure 4 – Free Windows® GUI



## 4.2 Rear Panel

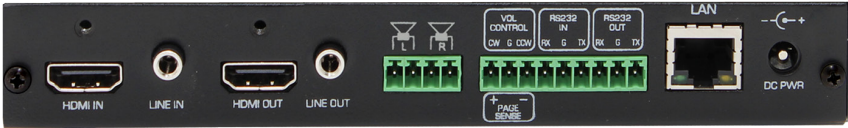

Figure 5 – Rear Panel

### HDMI IN

Connect to compatible video source. (e.g., such as a DVD or Blu-ray player).

### LINE IN

Connect to compatible line level audio source. (e.g., such as a MP3 or Microphone).

#### **NOTE**

*The Line input is configured for nominal Consumer Level (typical of MP3 players or wireless microphone receivers).*

*This input connector is stereo (Tip=Left channel, Ring=Right Channel). Care must be taken when connecting to a mono signal or a balanced signal.*

*When connected to an unbalanced mono source, both tip and ring of the EMX-AMP should be connected to the mono audio. Adapter cables are commercially available.*

*If connecting to a balanced mono source where there are +Sig and -Sig in addition to ground, make sure it has enough level (not compatible with low-level microphones, and connect using one of the following methods).*

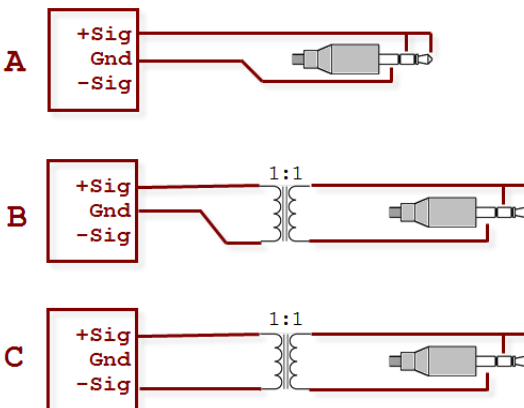

Figure 6

### HDMI OUT

Connect to compatible video sink. (e.g., such as a LCD or Projector).

### LINE OUT

Unbalanced stereo output. Connect to compatible line level audio output devices (e.g., such as headphones)

### L/R Speaker Outputs

Connect 8 or 16 ohm speakers to the 4-position terminal strip, 25 watts per channel maximum. See section [4.6](#) for more information.

### VOL Control / PAGE Sense

These connections have different purposes based on the system configuration.

- By default, connect a compatible rotary encoder to the **CW**, **CCW** and **GND** terminals for system volume control.



Figure 7 - Optional UI-KNOB-DP

- **OR**, connect a compatible PAGE SENSOR (Model VSA-PGSNS) to the **CW** and **CCW** terminals for automated PAGE Muting control.



Figure 8 - Optional VSA-PGSNS page sensor clamp

- **OR**, connect a switch between the **CW** and **GND** terminals for automated PAGE Muting control. If paging system has a relay output that indicates page in progress, instead of using the page sensor clamp described above, you can connected the relay to these terminals and configure the system to use it.
- **OR**, connect a switch between the **CCW** and **GND** terminals for automated transmission of the user programmed RS-232 ON and OFF strings from the RS-232 OUT terminals. This is typically used to send RS-232 commands based on contact closure input from compatible occupancy sensor.

### RS-232 IN

Connect the PC's RS-232 port to the input of the unit with a 3-pin terminal connector.

### RS-232 OUT

Connect RS-232 out to the controlled device such as a projector using a 3-pin terminal cable.

### LAN

Available on the Model EMX-I-AMP, connect to the compatible LAN network.

### DC PWR

Connect to the power supply shipped with the unit. See Section [4.4](#)

## 4.3 Factory Default

If the Power Button and Line Button are held for more than 3 seconds, this model can be set to the 'FACTORY DEFAULT' state.

## 4.4 Power Connection

A 120/240 VAC 50/60 HZ to 18 Volt DC 5A external universal power supply provides all the power required for the system to operate (*P/S Model: 511-PSD1850APL06*).



Figure 9 – Power Supply

## 4.5 LINE IN Connection

The LINE IN connection expects a consumer line level signal and is optimized for stereo line output of PC's, MP3 players, Smart Phones, etc.

Since various sources may possibly output less or more than nominal levels expected, there is a gain/trim adjustment on the line input to help set the level of Line Input about the same as the audio in HDMI.

The Line input is not compatible with low level microphones. It does not provide enough gain for low level microphone signals.

When using wireless (RF or IR based) microphones use the line output of the Microphone receiver to connect to the input of the EMX-AMP.

### NOTE

*If nothing is connected to the 3.5mm audio input, it is recommended to unselect the LINE in the audio mix. This eliminates any possible residual noise picked up by the analog circuits connected to the unused LINE input*

## 4.6 L/R Speaker Connections

The audio amplifier is designed to drive loads equal to or greater than 8  $\Omega$

Using lower loads may cause an over-current shutdown of the audio amplifier, this be detected and the amplifier will be reset.

Audio output from the amplifier will mute during this time.

It is recommended that when using a single speaker for each side to use 8 or 16  $\Omega$  speakers.

The amp can drive 50 watts total (25 watts per channel) when using 8  $\Omega$  speakers, which may be loud for a small room. Using 16  $\Omega$  speakers will cut the power delivered by half.

To drive 2 speakers from each side (total of 4 speakers in the room), connect two 16  $\Omega$  speakers in parallel or two 4 $\Omega$  or 8  $\Omega$  speakers in series as shown below. Never connect two 8  $\Omega$  speakers in parallel.

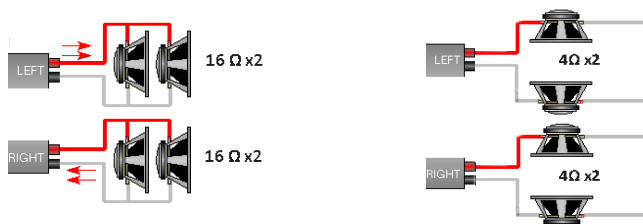

Figure 10 – Speaker Connection Example

## 5.0 WebGUI and Telnet Operation

EMX-I-AMP has a built in webpage that can control the basic functions of this model via LAN. You can power the device on and off, select the Audio Mix, control volume up/down/mute functions, and if you have programmed RS-232 ON and OFF commands of your display, you can also control the power of the TV (or set it for Auto where the commands are automatically sent based on video detection).

The webpage has buttons and indicators that show the state of that feature. The indicators are active even if buttons are disabled.

### 5.1 Amp Power

#### PWR Button

Click this button to turn the unit ON. **Note:** When the system is OFF, all buttons are disabled (grayed out) except for the PWR button.

### 5.2 Audio Mix

#### HDMI Button

Click this button to enable the HDMI Audio in output

#### LINE Button

Click this button to enable the LINE IN Audio. If you are not using Line Input in your setup, disable it.

### 5.3 Volume Control

#### UP & DN Buttons

Click these buttons to Increase or decrease the volume. Slide the volume bar to adjust the volume.

#### Mute Button

Click this button to mute the output audio

### 5.4 External Device Control

These buttons are for controlling the device connected to the RS-232 output port of the EMX-I-AMP (typically a TV or video projector with RS-232 control port).

#### AUTO Button

Click this button to enable or disable the Auto Output Command feature. In this mode the unit will look for HDMI signal on its input and will sent programmed commands to the TV. **Note:** When AUTO is enabled, the PWR, ON and OFF buttons are disabled.

#### ON Button

Click this button to send the user programmed RS-232 ON String to RS-232 OUT

#### OFF Button

Click this button to send the user programmed RS-232 OFF String from the RS-232 OUT



Figure 11– Webpage Example  
(As viewed on a smart phone)

## 5.5 Locating the device on a LAN

This model is shipped from the factory set for DHCP. The device will get an IP address from the compatible LAN network router.

The users may set the device to have a static address by using the Windows™ Software GUI available for download from <http://www.hallresearch.com>.

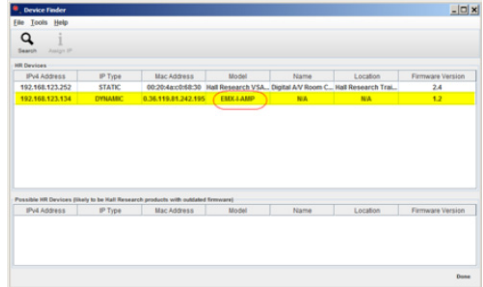

Figure 12– Windows GUI

The Hall Research **Device Finder**

software is available for download from <http://www.hallresearch.com> to locate all models on compatible LAN networks.

## 5.6 Telnet

The model EMX-I-AMP is controllable across a compatible LAN network via the device IP address on PORT 6324. The control commands are the same as the RS-232 control commands.

## 6.0 SENSE Function

This model has the ability to implement “priority page sense” function to mute the audio output when the system senses a page in the PA system.

Two methods can be used. (1) PAGE SENSOR CLAMP or CONTACT CLOSURE.

### NOTE

*Since page sense feature uses the same screw terminals as the rotary encoder, it is not available when the multifunction pins are configured for Rotary Encoder.*

## 6.1 PAGE SENSOR

This is an optional non-invasive audio transformer clamp that goes over existing wiring of the PA system. Simply clamp it over one of the wires going to the PA speakers. It detects PA announcement by monitoring the electric current in the wire when an announcement is in progress. When a “Page Sense” signal of sufficient amplitude is detected, the audio output of the EMX-AMP is automatically muted.



Figure 13 – Optional Page Sensor Clamp

If it is not possible to use the clamp (for example if the paging speaker is using Cat5 cabling), then if the paging system has a relay output (for alarm), you can use the contact closure to mute the audio output (see section [6.3](#))

**NOTE**

*The optional Page Sensor works with 25 V or 70 V and even some 8 Ohm PA systems. It is not designed for, two-way intercoms or IP-based paging systems. The sensor measures the AC audio current going to the external PA speaker and compares it against a "set point" to ignore background PA system noise. The mute trigger sensitivity is easily set using the software from any PC.*

## 6.2 Page Sensor Installation

- To install the VSA-PGSNS, locate the external PA wiring.
- Isolate one of the wires from the pair to run through the sensor. Carefully separate the wire pair taking caution not to cut the line or expose the wire inside the insulation.
- Wrap one of wires around the sensor lid 2-3 times as shown. The sensitivity is related to the number of turns used.
- Connect the leads on the sensor to the EMX-AMP terminals labeled "**SENSE**" (**CW and CCW**). Connect white to CW (+) and black to CCW (-) terminals.
- With the sensor installed the sensitivity can be adjusted using the Windows™ Software GUI.

## 6.3 Page Mute on Contact Closure

Connect a normally open switch between the **CW and GND** terminals.  
Closed = Muted. Open = NOT Muted.

## 7.0 Ducking Function

The EMX-AMP provides a basic "Ducking" feature where if audio is detected on the Line Input, the HDMI audio volume is automatically reduced. This is a useful feature when the line input is from a speaker's voice (e.g. via wireless microphone system). If Ducking function is active, then when the speaker begins to talk, the EMX-AMP will reduce the volume of the HDMI. This way the speaker's voice will be heard.

The "Ducking" feature constantly monitors the LINE IN audio level and when a signal of sufficient amplitude is detected, the HDMI audio input volume level will automatically be 'reduced' by the amount specified in the configuration. After the LINE IN audio level drops below the threshold, and after small delay, the HDMI audio input will automatically be returned to its previous level.

The "Ducking" Threshold and Ratio are settable via the Windows™ Software GUI.

## 8.0 Mono Output Mix

The EMX-AMP has the ability to mix the left and right channels and produce a mono output (where both left and right speakers sound the same). This selection is done via the Windows GUI or using the MOx serial command.

## 9.0 Serial Commands

- The following table lists the RS-232 commands:
  - Each command must be terminated by a single carriage return character (hex 0D).
  - Invalid input, spaces and line feeds characters (hex 0A) are ignored.
- RS-232 communication on the RS-232 IN terminal strip is:
  - **9600 bps, 8 Bit, No Parity, 1 Stop bit.**
- RS-232 communication on the RS-232 OUT terminal strip is:
  - Configurable, **factory default is 9600 bps, 8 Bit, No Parity, 1 Stop bit.**
  - The OUTPUT baud rate can be changed via Software GUI or via the “XBx” and “XPx” commands.
- <CR> in the table below refers to a single carriage return character (0x0D)
- “Error – Invalid Command” is sent in response to invalid RS-232 commands
- “Error” is sent in response to invalid command parameters

## 9.1 Serial Connections

- (3) Screw Terminal - RS-232 IN (TX, GND and RX)
- (3) Screw Terminal - RS-232 OUT (TX, GND and RX)

Command	Response	Function and Example
FW	FWx.y<CR>	Current firmware version. X and Y represent the firmware version numbers. (e.g., FW1.1<CR>)
PWx	PWx<CR>	Controls power status. PW?<CR> -- Query current power setting PW1<CR> -- Turn power on PW0<CR> -- Turn power off ( <b>Factory Default</b> )
LRx	LRx	Controls Line Level Audio Input LR?<CR> -- Query current Line Level Audio setting LR1<CR> -- Turn on Line Level Audio ( <b>Factory Default</b> ) LR0<CR> -- Turn off Line Level Audio
HDx	HDx<CR>	Controls HDMI Audio Input HD?<CR> -- Query current HDMI Audio setting HD2<CR> -- Turn on ARC Audio (valid in ARC Mode – AR1) HD1<CR> -- Turn on HDMI Audio ( <b>Factory Default</b> ) HD0<CR> -- Turn off HDMI Audio
VOLxxx	VOLxxx<CR>	Controls Audio output level. Allowable range is 0 to 100%. VOL?<CR> -- Query current volume level VOL50<CR> -- Set volume level to 50% VOL0<CR> -- Set volume level to 0% ( <b>Factory Default</b> )
VUPxxx	VOLxx<CR>	Controls Audio output level. Optional range is 0 to 100%. VUP<CR> -- Adjust volume level up 2% VUP10<CR> -- Adjust volume level up 10%
VDNxx	VOLxx<CR>	Controls Audio output level. Optional range is 0 to 100%. VDN<CR> -- Adjust volume level down 2% VDN10<CR> -- Adjust volume level down 10%



Command	Response	Function and Example
VCx	VCx<CR>	<p>Controls sub-circuit gain settings</p> <p>VC?&lt;CR&gt; – Query current volume/gain control setting</p> <p>VC0&lt;CR&gt; – Line Input Preamp Gain (defaulted to 70%)</p> <p>VC1&lt;CR&gt; – Reserved (do not use)</p> <p>VC2&lt;CR&gt; – Reserved (do not use)</p> <p>VC3&lt;CR&gt; – Overall Output Gain Setting (Factory Default)</p> <hr/> <p><b>Note:</b></p> <p>It is recommended that the user always return the setting to VC3 (default) after use. VC0 command is used to adjust the balance between HDMI and Line input levels. After the adjustment the user must set the VC to 3 so volume commands affect the output volume and not preamp gain. VC0 is controllable through the USB port using Windows GUI. Please see <a href="#">Figure 2</a> for audio signal flow diagram.</p> <hr/> <p><b>For example:</b></p> <p>To set the LINE Input to 50% Volume and then reset the control to the default LINE+HDMI/ARC, use:</p> <p>VC0&lt;CR&gt;VOL50&lt;CR&gt;VC3&lt;CR&gt;</p>
MUTx	MUTx<CR>	<p>Controls the MUTE status</p> <p>MUT?&lt;CR&gt; – Query current Mute Setting</p> <p>MUT1&lt;CR&gt; -- Turn on Audio Muting</p> <p>MUT0&lt;CR&gt; -- Turn off Audio Muting (Factory Default)</p>
ARx	ARx<CR>	<p>Controls ARC Mode (Audio Return Channel)</p> <p>AR?&lt;CR&gt; – Query current ARC mode setting</p> <p>AR1&lt;CR&gt; – Turn on ARC Mode</p> <p>AR0&lt;CR&gt; – Turn off ARC Mode (Factory Default)</p> <ul style="list-style-type: none"> <li>When ARC mode is turned <b>off</b>, using the HDMI button on the front panel will toggle between HDMI audio and no HDMI audio.</li> <li>When ARC mode is turned <b>on</b>, using the HDMI button on the front panel will toggle between ARC Audio and No ARC Audio.</li> </ul>
AUx	AUx<CR>	<p>Controls AUTO DETECT Mode</p> <p>AU?&lt;CR&gt; – Query current Auto Detect Mode Status</p> <p>AU1&lt;CR&gt; -- Auto Detect Mode Active</p> <p>AU0&lt;CR&gt; -- Auto Detect Mode In-Active (Factory Default)</p>
EDx	EDx<CR>	<p>Controls EDID mode setting</p> <p>ED?&lt;CR&gt; – Query current Mute Setting</p> <p>ED1&lt;CR&gt; -- Pass-Thru (Factory Default)</p> <p>ED0&lt;CR&gt; -- Emulated</p>
FD	FD<CR>	<p>Resets device to Factory Defaults</p> <p>Unit will reboot</p>
MOx	MOx<CR>	<p>Controls the MONO/STEREO Status</p> <p>MO?&lt;CR&gt; – Query current MONO/Stereo Setting</p> <p>MO1&lt;CR&gt; -- Turn on MONO</p> <p>MO0&lt;CR&gt; -- Turn off MONO (Stereo) (Factory Default)</p>
FPx	FPx<CR>	<p>Controls the Front Panel Lock Status</p> <p>FP?&lt;CR&gt; – Query current Front Panel Lock Setting</p> <p>FP1&lt;CR&gt; -- Turn on Front Panel Lock</p> <p>FP0&lt;CR&gt; -- Turn off Front Panel Lock (Factory Default)</p>

## HDMI Audio Extractor with Power Amplifier

Command	Response	Function and Example
ST	System status	Queries system status ST<CR> -- Query the current system status Current Status for the commands below: IP?, SB?, GW?, PW?, LR?, HD?, MUT?, VOL?, MO?, VC?, AU?, AT?, AR?, BP?, ED?, DA?, XC?, XB?, XP?
XBx	XBx<CR>	Controls the RS-232 Out Baud Rate XB?<CR> -- Query current Output Baud Rate Setting XB4<CR> -- Set Baud Rate to 9600 (Factory Default) • The baud rate can be set to any of the following: XB1 = 1200, XB2 = 2400, XB3 = 4800 XB4 = 9600, XB5 = 19200, XB6 = 38400 XB7 = 57600, XB8 = 115200
XPx	XPx<CR>	Controls the RS-232 Out Parity XP?<CR> -- Query current Output Parity Setting XP0<CR> -- Set Parity to 'NONE' (Factory Default) XP1<CR> -- Set Parity to 'EVEN' XP2<CR> -- Set Parity to 'ODD'
XT	XT<CR>	Transmit from RS-232 OUT with specific baud and parity Terminated with <0x17><0x0D>
XR	Up to 128 bytes received on RS-232 OUT RX line	Reads characters received on the RS-232 OUT RX terminal. 128 characters maximum
IP? or  IPx	IPxxx.xxx.xxx.xxx<CR>	Controls IP Address setting IP?<CR> -- Query current IP Address   IP192.168.001.100<CR> (note use of " " in the command) - Set IP Address to 192.168.001.100
		<b>Note:</b> Setting takes effect when Gateway address is set
SB? or  SBx	SBxxx.xxx.xxx.xxx<CR>	Controls Subnet Mask setting SB?<CR> -- Query current Subnet Mask   SB255.255.255.000<CR> (note use of " " in the command) - Set the Subnet Mask to 255.255.255.000
		<b>Note:</b> Setting takes effect when Gateway address is set
GW? or  GWx	GWxxx.xxx.xxx.xxx<CR>	Controls Gateway address setting GW?<CR> -- Query current Gateway address   SB255.255.255.000<CR> (note use of " " in the command) - Set the Subnet Mask to 255.255.255.000
DHCPx	DHCPx<CR>	Controls the DHCP status on LAN Enabled Versions DHCP?<CR> -- Query current DHCP Setting DHCP1<CR> -- Turn on DHCP (Factory Default) DHCP0<CR> -- Turn off DHCP (STATIC Addressing)
SPx	SPx<CR>	Controls the Serial Data Pass-Thru Status SP?<CR> -- Query current Serial Pass-Thru Setting SP1<CR> -- Turn on Serial Pass-Thru SP0<CR> -- Turn off Serial Pass-Thru (Factory Default)
BPx	BPx<CR>	Controls transmission of stored serial commands BP?<CR> -- Query current Button Press Status BP1<CR> -- Send "ON String" BP0<CR> -- Send "OFF String" (Factory Default)

Command	Response	Function and Example
AUx	AUx<CR>	<p>Controls AUTO DETECT Mode</p> <p>AU?&lt;CR&gt; – Query current Auto Detect Mode Status</p> <p>AU1&lt;CR&gt; – Auto Detect Mode Active</p> <p>AU0&lt;CR&gt; – Auto Detect Mode In-Active (<b>Factory Default</b>)</p>
ATx	ATx<CR>	<p>Controls the Auto Detection Trigger Settings</p> <p>AT?&lt;CR&gt; – Query current Auto Detection setting</p> <p>AT0&lt;CR&gt; – Auto Detection Disabled (<b>Factory Default</b>)</p> <p>AT1&lt;CR&gt; – +5VDC on HDMI INPUT</p> <p>AT2&lt;CR&gt; – Video on HDMI INPUT</p> <p>AT3&lt;CR&gt; – Contact Closure (<b>CCW &amp; GND</b>)</p> <p>Auto Detect (AU1) must be active for a Trigger to occur</p> <hr/> <p><b>Note:</b> Using the AUTO DETECT Contact Closure will disable the ability to use the Encoder or Page Sensor.</p>
PGx	PGx<CR>	<p>Controls the Encoder/Page Sensor Setting</p> <p>PG?&lt;CR&gt; – Query current Encoder/Page Sensor setting</p> <p>PG0&lt;CR&gt; – Rotary Encoder (<b>Factory Default</b>)</p> <p>PG1&lt;CR&gt; – Page Sensor (Model VSA-PGSNS)</p> <p>PG2&lt;CR&gt; – Contact Closure (CW &amp; GND)</p> <hr/> <p><b>Note:</b> Using the Rotary Encoder or Page Sensor will disable the ability to use the PAGE SENSE (<b>CW &amp; GND</b>) and AUTO DETECT (<b>CCW &amp; GND</b>) contact closures.</p> <p>Using the PAGE SENSE (<b>CW &amp; GND</b>) Contact Closure will disable the ability to use the Rotary Encoder or Page Sensor.</p>
XCxx	XCx <CR>	<p>Controls device addressing</p> <p>XC?&lt;CR&gt; – Query current device address</p> <p>XC0&lt;CR&gt; – Set device address to 0 (<b>Factory Default</b>)</p> <p>XC1&lt;CR&gt; thru XC99&lt;CR&gt;</p> <p>Set device address to 1 thru 99</p> <hr/> <p><b>Note:</b> All devices in the daisy chain will respond with the device address, in order (closest to RS-232 IN 1<sup>st</sup> and then each subsequent unit).</p>
DA?	DA? <CR>	<p>Queries current device ID # (<b>Factory Default = 0</b>) (Set via USB GUI).</p>

## 9.2 Automatic Power Control of Display based on HDMI Input Detection

This model has the ability to send user programmed RS-232 strings from the RS-232 OUT terminal strip based on different events:

**Contact Closure** – External contact closure connected on the **CW & GND** terminals. Contact closed sends the ON string; Contact open sends the OFF string. Using the Contact Closure disables the use of a rotary encoder or Page Sensor.

**Source +5V** – ON string sent when +5V from the source is detected, OFF string sent when +5V from the source is no longer detected.

**Source Video** – The ON string is sent when the HDMI Source Video is solid for more than 1 second. The OFF string is sent when the HDMI Source Video is no longer detected. The delay before sending the OFF string is programmable from approximately 1 second to 240 minutes (+/- 10%).

## 9.3 Device Addressing for special daisy-chain operation

The EMX-AMP has the ability to daisy chain the RS-232 IN and RS-232 OUT together with other units where a serial controller at the head of the chain is able to individually control the volume and mute functions of all the units in the chain.

This is accomplished by setting a unique device id for each model in the chain and then enabling the serial pass-thru mode. This allows the RS-232 commands from the serial controller to pass thru each unit to the end of the chain. Commands will only work on the last device that the 'XCx' serial command was set for.

The factory default setting is DEVICE ADDRESS "0". All units in the daisy chain with the same DEVICE ID # ('DA?') will react to those commands. For example, with a factory default setting of "0", sending a "PW1" command to a number of units daisy chained together will result in all units powering on.

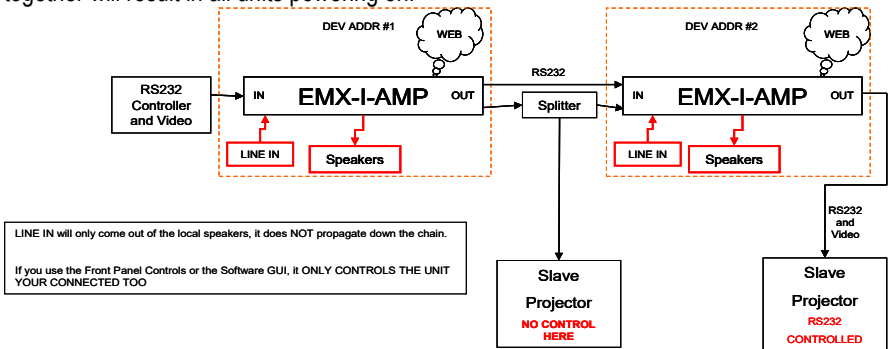

Figure 14 – Daisy Chain Example

- RS-232 Controller connected to Unit #1 RS-232 IN
- Unit #1 RS-232 OUT connected to Unit #2 RS-232 IN
- Unit #1 set for Device Address #1 (Via Windows™ Software GUI)
- Unit #1 set for Serial Pass-Thru (Via Windows™ Software GUI or RS-232 command "SP1")
- Unit #2 set for Device Address #2 (Via Windows™ Software GUI)

- To control Unit #1, send the XC1<CR> serial command 1<sup>st</sup>.
  - All subsequent RS-232 commands will only be understood by Unit #1. Unit #2 will ignore all the commands.
- To control Unit #2, send the XC2<CR> serial command.
  - All subsequent RS-232 commands will only be understood by Unit #2. Unit #1 will ignore all the commands

## 10.0 Troubleshooting

If you are experiencing problems getting the amp to work properly, please use the following troubleshooting suggestions.

- Make sure that all of the connections are solid. Loose connections are the number one cause of issues.
- Try resetting the system by unplugging the power supply, waiting 5 seconds and plugging it back.
- Try performing a factory default. Holding the Power Button and Line Buttons together for more than 3 seconds will reset the unit back to 'Factory Default'.

**NOTE** *Ensure you backup your configuration first using the Windows™ GUI. Setting Factory Default will delete any user programmed RS-232 strings*

- Check the state of the LED's on the front of the unit. Refer to the table in Section [4.1](#) to interpret the status being indicated.
- Make sure the display is compatible with the video source by connecting them directly.
- If you still are not able to get the system working properly, contact Hall Research support (preferably via email or the form on support page of [www.hallresearch.com](http://www.hallresearch.com)) with a detailed description of the issue and the troubleshooting steps you have taken.

Do not open or try to repair the unit yourself as this will void your warranty.

To return the device for repair, you must contact HR Support at 714-641-6607 or via email or web.

To ship the unit back for repair, make sure to obtain a Return Material Authorization (RMA) number from Hall Research.

## 11.0 Specifications

### Video

Standards	DVI (single link) HDMI 1.4 video specifications including 12 bit color depth, 3D video, and 4K@30 HDCP 1.1
Signal type	TMDS
Connectors	(2) Locking HDMI
Resolutions	DVI signal           VGA (640x480) thru WUXGA (1920x1200) HDTV signal        480i through 4K@30 Hz

### Audio

Formats	HDMI Embedded Audio including: LPCM (32-192kHz sample rate)
---------	---

### Other Signals

DDC	DDC from HDMI receiver in the EMX-AMP to the source and from HDMI sink to the HDMI transmitter in the AMP. DDC supports EDID management and HDCP handshake
CEC	Pass-Thru
RS-232	Each RS-232 Port uses 3 pins on the screw terminal. RS-232 IN Baud Rate: 9600, N, 8, 1 RS-232 OUT Baud Rate: Configurable at 1200, 2400, 4800, 9600, 19200, 38400, 57600, or 115200 Output factory default is 9600, N, 8, 1
USB	(1) Mini-B
Encoder	3 Terminal, 24 Detent, 15 Position Grey Code (Rotary Encoder is optional)

### General

Power Supply	100 VAC to 240 VAC, 47-63 Hz, External; 18 VDC, 5A (Model: 511-PSD1850APL06)
Temp/humidity	Storage: -40 to +158 °F (-40 to +70 °C) / 10% to 90%, non-condensing Operating: +32 to +122 °F (0 to +50 °C) / 10% to 90%, non-condensing
Typical DC Current Draw	18 VDC, 5.0 A Power Supply EMX-I-AMP (Non -I unit) use 500 mADC less for VIDEO ON values  ON (Video Only no audio output): 600 mADC ON (100% Audio volume): 3.25 ADC OFF: 100 mADC
Cooling	Convection
Enclosure type	Metal (Steel)
Dimensions	1.25" H x 7" W x 4.3" D (32mm H x 179mm W x 109mm D) Depth excludes connectors
Product weight	Amplifier           10 oz (0.63 lb or 284 g) Kit (shipping)     37 oz (2.3 lb or 1050 g) includes: EMX-AMP, power supply, power cord, manual, and packaging
Vibration	ISTA 1A in carton (International Safe Transit Association)
Safety	CE
EMI/EMC	CE, FCC Class A
MTBF	90,000 hours (Calculated Estimate)
Warranty	3 years parts and labor

*Specifications are subject to change without notice*





© Copyright 2016. Hall Research, Inc.  
All rights reserved.