

Technical Manual



JBL AWC82/-BK

SPECIFICATIONS

ACOUSTIC & ELECTRICAL SPECIFICATIONS:

- Nominal Impedance: 8 Ohms
- Long-Term System Power Rating: 250W, 2 hrs
200W, 100 hrs
- Frequency Response (± 3 dB): 100 Hz - 20 kHz
- Frequency Range (-10 dB): 80 Hz - 20 kHz
- Maximum SPL: Direct 8 ohm: 118 dB (peaks of 124 dB)
200W Tap: 117 dB
- System Sensitivity: 94 dB, (Ave 100 Hz - 20 kHz)
2.83V @ 1 Meter
- Crossover Frequency: 1.8 kHz, 3rd order (18 dB/oct) high-pass plus conjugate to HF, 2nd order low-pass to LF

SYSTEM COMPONENTS:

- Cabinet: Enclosure (Not for Sale)
- Grille: 5026574, 5026687 (BK)
- Low Frequency Driver: Kevlar-reinforced cone with weather treatment, 50 mm (2 in) voice coil
- DC Resistance: 5.2 ohm

SYSTEM COMPONENTS: (CONT'D)

- High Frequency Transducer: 25 mm (1 in) diaphragm and voice coil diameter, high temperature polymer patented design, fluid-cooling
- DC Resistance: 3.6 ohm +/- 0.2 ohm
- Network Assembly: 5026640

AURAL SWEEP TEST SPECIFICATIONS:

- A. System Aural Sweep Test: 7V Input, 50 Hz to 20 kHz
- B. L.F. Aural Sweep Test: 10V Input, 20 Hz to 1 kHz
- C. H.F. Aural Sweep Test: 2V Input, 2 kHz to 16 kHz

PHYSICAL SPECIFICATIONS:

- Enclosure Dimensions: 300 x 300 x 305 mm D
(11.8 x 11.8 x 12.0 in.D.)
- Net Weight: 21.5 lb (9.8 kg.)

WARRANTY INFORMATION:

- Refer to Warranty Statement packed with each product.

PACKAGE

Warranty 59660

Gland Nut
5026625

Terminal
Compartment
Cover
5026676
5026753 (BK)

Screw Bag
5026679
5026756 (BK)

Serial Number
Label
5026583
5026696 (BK)



Model Label
5026580
5026693 (BK)

Tap Switch
Label
5026628

Serial Number
Corner Label for
Carton
5026590
5026702 (BK)

U-Bracket
5026577
5026690 (BK)

Cardboard
5026658

Top, Styrofoam
5026661
OM Bag
5026655

Bottom, Styrofoam
5026664

Master Carton
5026586
5026699 (BK)

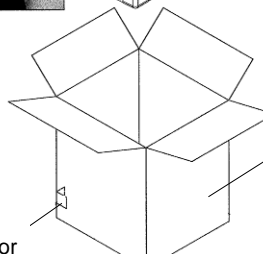

WIRING DIAGRAM

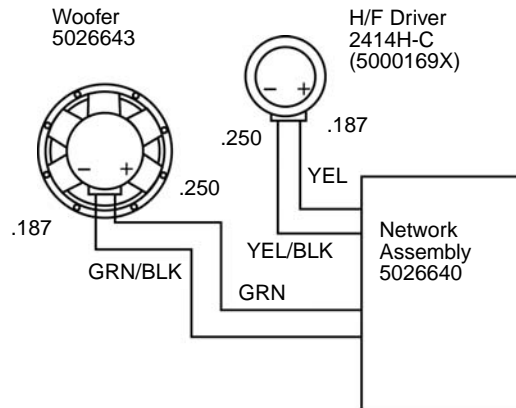

SEE NETWORK SCHEMATIC (5026640) PAGE 2

Transformer Taps: 70V: 200W, 100W, 50W, 25W
100V: 200W, 100W, 50W

NOTE: INDIVIDUAL PARTS FOR THE ABOVE CROSSOVER ARE NOT AVAILABLE.
A COMPLETE REPLACEMENT ASSEMBLY SHOULD BE ORDERED.

JBL AWC82/-BK

NETWORK ASSEMBLY SCHEMATIC - (5026640)

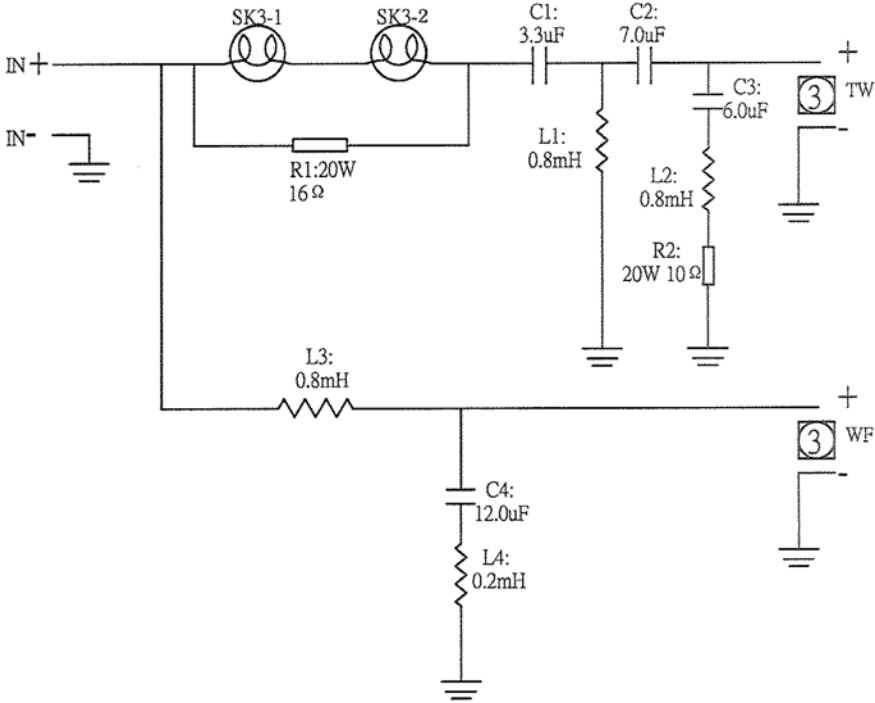

Transformer Diagram

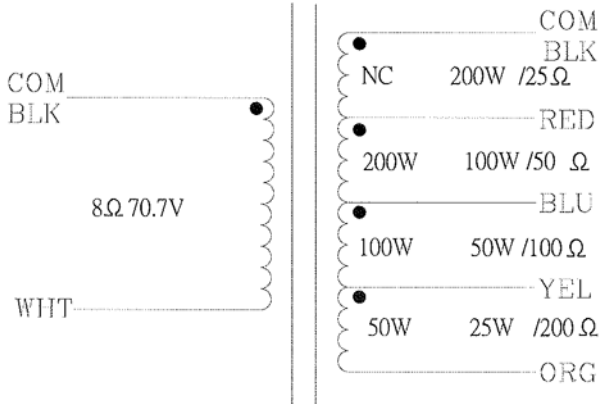

Transformer TAPS

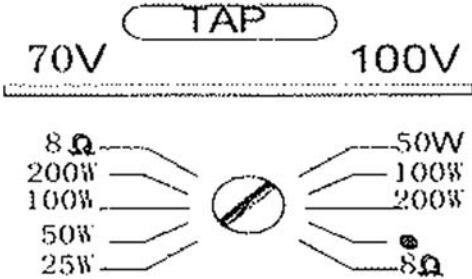

Individual Parts for the above crossover are not available.
A complete replacement assembly should be ordered.

JBL AWC82/-BK

JBL AWC82/-BK

COMPONENT EXPLODED VIEW

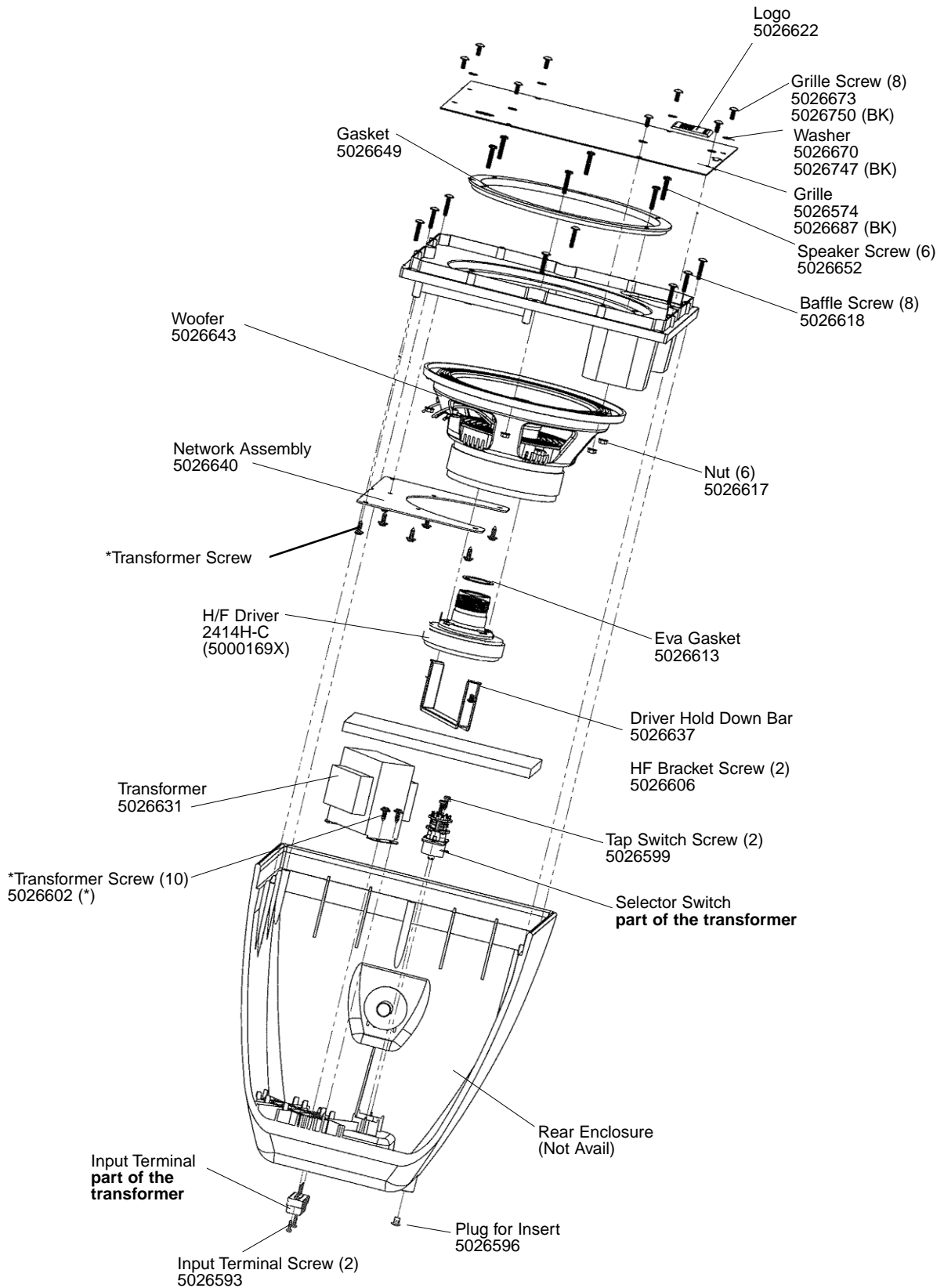

JBL AWC82/-BK