

Kramer Electronics, Ltd.



USER MANUAL

Model:

6241HD

4x1 HD-SDI Switcher

Contents

1	Introduction	1
2	Getting Started	1
2.1	Quick Start	2
3	Overview	3
4	Your 6241HD 4x1 HD-SDI Switcher	4
5	Connecting the 6241HD 4x1 HD-SDI Switcher	5
6	Technical Specifications	6

Figures

Figure 1:	6241HD 4x1 HD-SDI Switcher Functions	4
Figure 2:	Connecting the 6241HD 4x1 HD-SDI Switcher	5

Tables

Table 1:	6241HD 4x1 HD-SDI Switcher Functions	4
Table 2:	6241HD Technical Specifications	6

1 Introduction

Welcome to Kramer Electronics! Since 1981, Kramer Electronics has been providing a world of unique, creative, and affordable solutions to the vast range of problems that confront the video, audio, presentation, and broadcasting professional on a daily basis. In recent years, we have redesigned and upgraded most of our line, making the best even better! Our 1,000-plus different models now appear in 11 groups¹ that are clearly defined by function.

Thank you for purchasing the Kramer DigiTOOLS® **6241HD** *4x1 HD-SDI Switcher*, which is ideal for:

- Video broadcast studios for signal routing
- Non-linear editing suites
- Video production studios

Each package includes the following items:

- **6241HD** *4x1 HD-SDI Switcher*
- Power supply (5V DC)
- This user manual²

2 Getting Started

We recommend that you:

- Unpack the equipment carefully and save the original box and packaging materials for possible future shipment
- Review the contents of this user manual
- Use Kramer high-performance high-resolution cables³

1 GROUP 1: Distribution Amplifiers; GROUP 2: Switchers and Matrix Switchers; GROUP 3: Control Systems; GROUP 4: Format/Standards Converters; GROUP 5: Range Extenders and Repeaters; GROUP 6: Specialty AV Products; GROUP 7: Scan Converters and Scalers; GROUP 8: Cables and Connectors; GROUP 9: Room Connectivity; GROUP 10: Accessories and Rack Adapters; GROUP 11: Sierra Products

2 Download up-to-date Kramer user manuals from our Web site at <http://www.kramerelectronics.com>

3 The complete list of Kramer cables is on our Web site at <http://www.kramerelectronics.com>

2.1 Quick Start

This quick start chart summarizes the basic setup and operation steps.

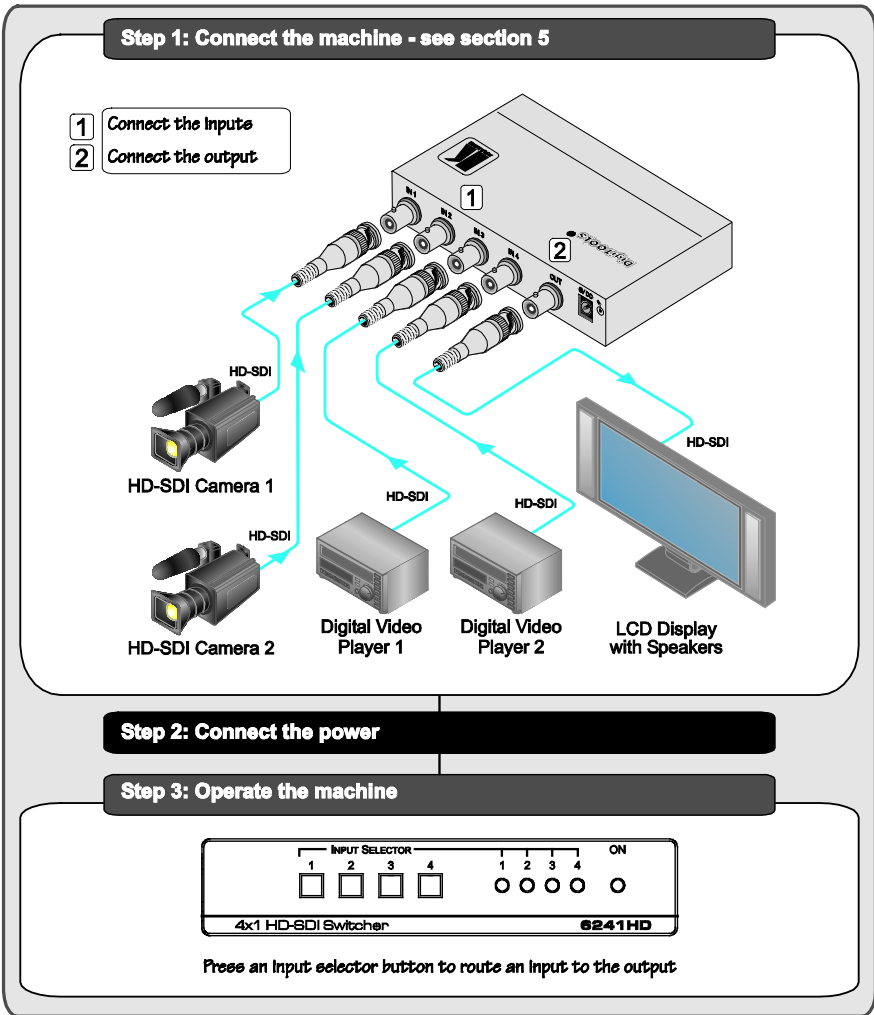

3 Overview

The **6241HD** *4x1 HD-SDI Switcher* is a high-performance switcher for HD-SDI serial digital video signals. It takes any one of four HD-SDI inputs, provides reclocking and equalization, and outputs the signal to one HD-SDI output.

The **6241HD** features:

- A maximum data rate up to 1.485Gbps
- HDTV compatibility
- SMPTE 259M, 344M and 292M compliance
- Adjustment-free operation
- Automatic equalization for losses on 75Ω coaxial cable¹
- Reclocking the input signal to provide a low-jitter serial digital output
- 8-bit and 10-bit video operation, automatically recognizing the word length

To achieve the best performance:

- Use only good quality connection cables² to avoid interference, deterioration in signal quality due to poor matching, and elevated noise levels (often associated with low quality cables).
- Avoid interference from neighboring electrical appliances that may adversely influence signal quality and position your Kramer **6241HD** away from moisture, excessive sunlight and dust



Caution – No operator-serviceable parts inside unit.

Warning – Use only the Kramer Electronics input power wall adapter that is provided with this unit³.

Warning – Disconnect power and unplug unit from wall before installing or removing device or servicing unit.

1 Up to hundreds of meters of cable (depending on the cable quality and the video standard)

2 Available from Kramer Electronics on our Web site at <http://www.kramerelectronics.com>

3 For example, part number 2535-052002

4 Your 6241HD 4x1 HD-SDI Switcher

Figure 1 and Table 1 define the unit.

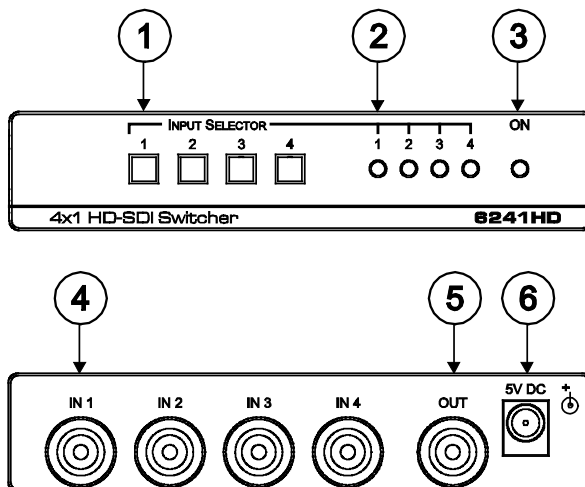

Figure 1: 6241HD 4x1 HD-SDI Switcher Functions

Table 1: 6241HD 4x1 HD-SDI Switcher Functions

#	Feature	Function
1	INPUT SELECTOR Switches	Select the serial digital video sources (from 1 to 4)
2	INPUT SELECTOR LEDs	Illuminate for the selected input (from 1 to 4)
3	ON LED	Illuminates when receiving power
4	INPUT BNC Connectors	Connect to the serial digital video sources (75Ω) (1 to 4)
5	OUT BNC Connector	Connect to the serial digital video acceptor (75Ω)
6	5V DC	+5V DC connector for powering the unit

5 Connecting the 6241HD 4x1 HD-SDI Switcher

To connect your **6241HD 4x1 SDI Switcher**, as illustrated in *Figure 2*:

1. Connect up to 4 serial digital video sources (for example, two HD-SDI digital broadcast cameras and two digital video players) to the four serial digital video IN BNC connectors¹.
2. Connect the serial digital video OUT BNC connector to the serial digital video acceptor (for example, an HD-SDI digital monitor).
3. Connect the 5V DC power adapter to the power socket and connect the adapter to the mains electricity.
Pressing an INPUT SELECTOR button routes that serial digital video input to the serial digital video output.

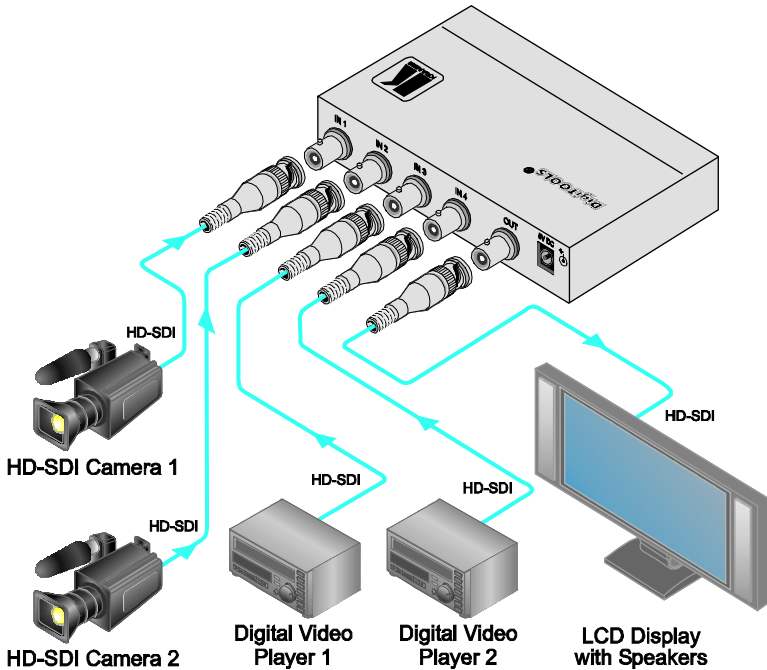

Figure 2: Connecting the 6241HD 4x1 HD-SDI Switcher

¹ You do not have to connect all the inputs

6 Technical Specifications

The **6241HD** technical specifications are shown in *Table 2*:

Table 2: 6241HD Technical Specifications¹

INPUTS:	4 SMPTE 259M/344M/292M serial digital video inputs (75Ω) on BNC connectors
OUTPUTS:	1 SMPTE 259M/344M/292M serial digital video output (75Ω) on BNC connectors
MAX. DATA RATE:	1.485Gbps
MAX. OUTPUT LEVEL:	800mVpp/75Ω
EQUALIZATION:	Automatic equalization for losses on 75Ω coaxial cable
DIMENSIONS:	12cm x 7.5cm x 2.5cm (4.7" x 2.95" x 0.98") W, D, H
POWER SOURCE:	5V DC, 410mA
WEIGHT:	0.25kg (0.6lbs) approx.
ACCESSORIES:	Power supply, mounting bracket
OPTIONS:	RK-T1 or RK-T3 rack mount kit

¹ Specifications are subject to change without notice

LIMITED WARRANTY

Kramer Electronics (hereafter *Kramer*) warrants this product free from defects in material and workmanship under the following terms.

HOW LONG IS THE WARRANTY

Labor and parts are warranted for seven years from the date of the first customer purchase.

WHO IS PROTECTED?

Only the first purchase customer may enforce this warranty.

WHAT IS COVERED AND WHAT IS NOT COVERED

Except as below, this warranty covers all defects in material or workmanship in this product. The following are not covered by the warranty:

1. Any product which is not distributed by Kramer, or which is not purchased from an authorized Kramer dealer. If you are uncertain as to whether a dealer is authorized, please contact Kramer at one of the agents listed in the Web site www.kramerelectronics.com.
2. Any product, on which the serial number has been defaced, modified or removed, or on which the WARRANTY VOID IF TAMPERED sticker has been torn, reattached, removed or otherwise interfered with.
3. Damage, deterioration or malfunction resulting from:
 - i) Accident, misuse, abuse, neglect, fire, water, lightning or other acts of nature
 - ii) Product modification, or failure to follow instructions supplied with the product
 - iii) Repair or attempted repair by anyone not authorized by Kramer
 - iv) Any shipment of the product (claims must be presented to the carrier)
 - v) Removal or installation of the product
 - vi) Any other cause, which does not relate to a product defect
 - vii) Cartons, equipment enclosures, cables or accessories used in conjunction with the product

WHAT WE WILL PAY FOR AND WHAT WE WILL NOT PAY FOR

We will pay labor and material expenses for covered items. We will not pay for the following:

1. Removal or installations charges.
2. Costs of initial technical adjustments (set-up), including adjustment of user controls or programming. These costs are the responsibility of the Kramer dealer from whom the product was purchased.
3. Shipping charges.

HOW YOU CAN GET WARRANTY SERVICE

1. To obtain service on you product, you must take or ship it prepaid to any authorized Kramer service center.
2. Whenever warranty service is required, the original dated invoice (or a copy) must be presented as proof of warranty coverage, and should be included in any shipment of the product. Please also include in any mailing a contact name, company, address, and a description of the problem(s).
3. For the name of the nearest Kramer authorized service center, consult your authorized dealer.

LIMITATION OF IMPLIED WARRANTIES

All implied warranties, including warranties of merchantability and fitness for a particular purpose, are limited in duration to the length of this warranty.

EXCLUSION OF DAMAGES

The liability of Kramer for any effective products is limited to the repair or replacement of the product at our option. Kramer shall not be liable for:

1. Damage to other property caused by defects in this product, damages based upon inconvenience, loss of use of the product, loss of time, commercial loss; or;
2. Any other damages, whether incidental, consequential or otherwise. Some countries may not allow limitations on how long an implied warranty lasts and/or do not allow the exclusion or limitation of incidental or consequential damages, so the above limitations and exclusions may not apply to you.

This warranty gives you specific legal rights, and you may also have other rights, which vary from place to place.

NOTE: All products returned to Kramer for service must have prior approval. This may be obtained from your dealer.

This equipment has been tested to determine compliance with the requirements of:

EN-50081:	"Electromagnetic compatibility (EMC); generic emission standard. Part 1: Residential, commercial and light industry"
EN-50082:	"Electromagnetic compatibility (EMC) generic immunity standard. Part 1: Residential, commercial and light industry environment".
CFR-47:	FCC* Rules and Regulations: Part 15: "Radio frequency devices Subpart B Unintentional radiators"

CAUTION!

⊗ Servicing the machines can only be done by an authorized Kramer technician. Any user who makes changes or modifications to the unit without the expressed approval of the manufacturer will void user authority to operate the equipment.

⊗ Use the supplied DC power supply to feed power to the machine.

⊗ Please use recommended interconnection cables to connect the machine to other components.

* FCC and CE approved using STP cable (for twisted pair products)



**For the latest information on our products and a list of Kramer distributors, visit our Web site: www.kramerelectronics.com where updates to this user manual may be found.
We welcome your questions, comments and feedback.**



Caution

Safety Warning:

Disconnect the unit from the power supply before opening/servicing.



Kramer Electronics, Ltd.

Web site: www.kramerelectronics.com

E-mail: info@kramerel.com

P/N: 2900-000588 REV 1