

CV-H20-HF

Compact Weatherproof Camera Housing
with Fan & Heater



Installation Instructions

Suitable for Compact Cameras (part#): CV343, CV350, CV365, CV342

CAUTION



WARNING

To reduce the risks of an electric shock, do not expose inside of this unit to rain or moisture.



Installation on a rainy day may also cause fog around the capsule.



Installation

Installation shall be done by qualified installer only and should conform to all local codes.



Ensuring Strength of Supporting Dome Housing Unit

The unit must be properly and securely mounted to a supporting structure capable of sustaining the weight of the unit. Recommended use of 3/8" stainless screws x three (3).



Prohibit Changes or Modifications of Equipment

You are cautioned that any changes or modifications not expressly approved in these instructions could void your authority to operate this equipment.



Basic Operating Environment Condition

We provide warranty for the products that are installed under normal outdoor -20°C ~ +50°C conditions. We are unable to provide warranty for the products which are installed indoor and exposed to constant high temperature over +50°C and over 90% humidity.

Operating temperature and humidity of camera varies from camera to camera. You are requested to confirm to camera specification with camera manufacturer and housing specification with us in advance. i.e. -20°C or below, you are requested to use additional heater and +50°C or above you are requested to use two blowers and sunshield.

Fasten wires tightly.

Attention: Keep wires away from the Fan / Heater, and do not disturb Fan/Heater's performance

Assembly Steps of the Camera and Wall Mount Bracket

1

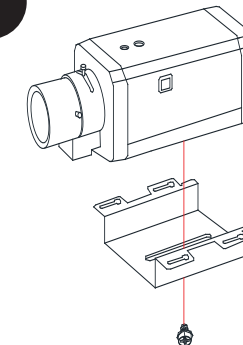

Screw the front mounting board on camera with 1/4 screws

2

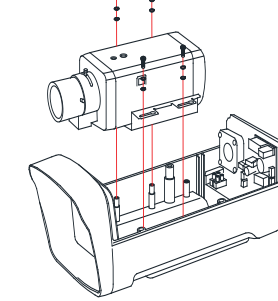

Screw the mounting board and camera onto inside of camera housing

3

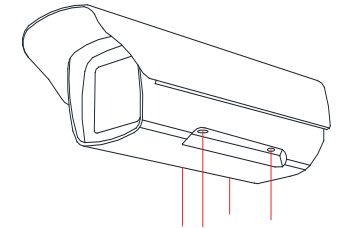

After internal wiring is completed, put on the box camera housing and tighten up the covert 5x27 button head cap screw

4

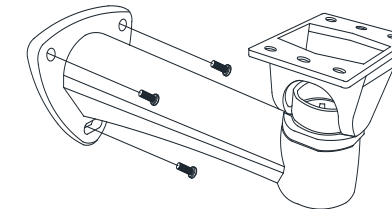

Attach wall mount bracket to the wall

5

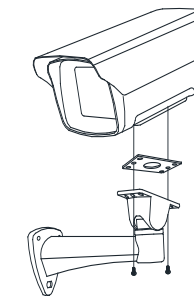

Through the rubber gasket, tighten up the bottom of the housing with the flat head 6x8 hex socket cap screw

6

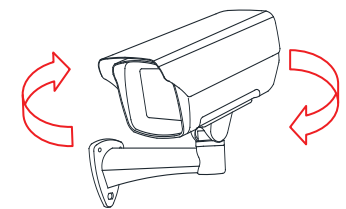

Adjust camera angle and tighten up the screws/bolts where indicated with an allen key

CV-H20-HF Installation

➔ The unit must be properly and securely mounted to a supporting structure capable of sustaining the weight of unit. We recommend using stainless screws.

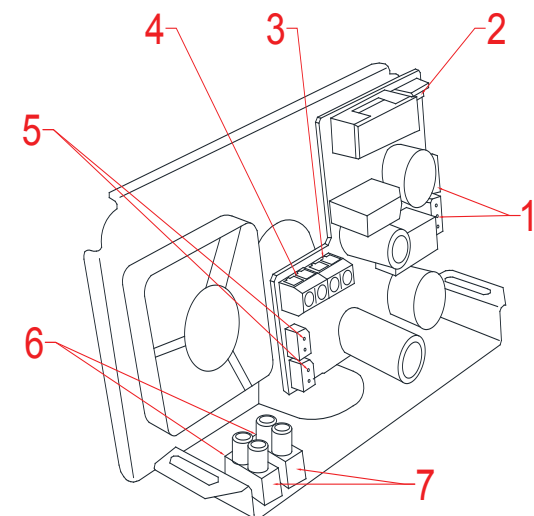

Assembly of the Cables

1. AC 24V HEATER
2. AC 24V IN
3. AC 24V OUT
4. DC 12V OUT
5. DC 12V FAN
6. AC 24V OUT
7. AC 24V POWER IN

CV-H20-HF Dimensions

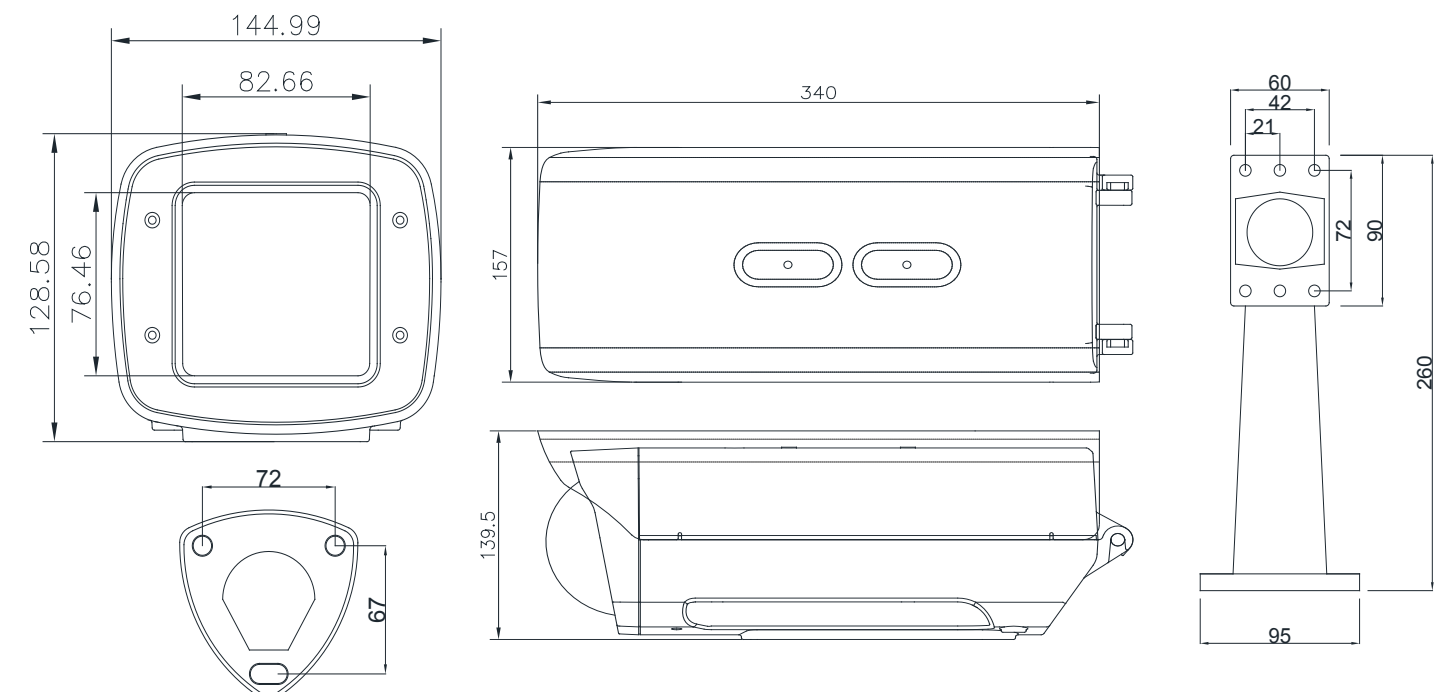

Important Safeguards

1. Read Instructions – All the safety and operating instructions should be read before operating the unit.
2. Retain Instructions – The safety and operating instructions should be retained for future reference.
3. All warnings on the unit and in the operating instructions should be adhered to.
4. Follow Instructions
5. Electrical Connections – Only a qualified electrician should make the electrical connections.
6. Attachments – Do not use attachments not recommended by the product manufacturer as they may cause hazards.
7. Cable Runs – All cable runs must be within permissible distance.
8. Mounting – This unit must be properly and securely mounted to a supporting structure capable of sustaining the weight of the unit. Accordingly:
 - a. The installation should be made by qualified installer.
 - b. The installation should be in compliance with local codes.
 - c. Care should be exercised to select suitable hardware to install the unit, taking into account both the composition of the mounting surface and the weight of the unit. Be sure to periodically examine the unit and the supporting structure to make sure that the integrity of the installation is intact. Failure to comply with the foregoing could result in the unit separating from the support structure and falling, with resultant damages or injury to anyone or anything struck by the falling unit.

Marshall Electronics, Inc.

Tel: (800) 800-6608 / (310) 333-0606 • Fax: 310-333-0688
www.Marshall-usa.com • support@marshall-usa.com