

VDA-106-3GS

1 x 6 3G/HD/SD-SDI
Reclocking Distribution Amplifier



User Manual

Safety and Notice



The **VDA-106-3GS** 1x6 3G/HD/SD-SDI Distribution Amplifier with Reclocking has been tested for conformance to safety regulations and requirements, and has been certified for international use. However, like all electronic equipment, the **VDA-106-3GS** should be used with care. Please read and follow the safety instructions to protect yourself from possible injury and to minimize the risk of damage to the unit.

- Follow all instructions and warnings marked on this unit.
- Do not attempt to service this unit yourself, except where explained in this manual.
- Provide proper ventilation and air circulation and do not use near water.
- Keep away the objects that might damage the device and assure that the placement of this unit is on a stable surface.
- Use only the power adapter, power cords and connection cables designed for this unit.
- Do not use liquid or aerosol cleaners to clean this unit. Always unplug the power to the device before cleaning.

INTRODUCTION ---

The VDA-106-3GS is a compact and reliable distribution amplifier which accepts a single SDI input and provides six identical outputs. All embedded data is passed transparently. Signals are reclocked and cable equalization is provided to support long cable runs. The VDA-106-3GS is useful for providing video to multiple destinations (recorders, displays, encoders) from a single video source.

FEATURES ---

- **3G/HD/SD serial digital distribution**
- **Six separately buffered and reclocked outputs**
- **Cable equalization and signal retiming**
- **Dual color LED indication of input lock and rate**
- **Passes all ancillary data**
- **Provides automatic input cable equalization up to 300m (1000ft)@SD, 150m (500ft)@HD/3G**

PACKAGE CONTENTS ---

- **1 x VDA-106-3GS**
- **1 x 5V power adapter**
- **1 x User Manual**

SPECIFICATIONS

Model Name	VDA-106-3GS	
Technical		
SDI standards	3G/HD/ SD -SDI	
Auto 3G/HD/SD detection	Yes	
Supported protocols	DVB-ASI at 270Mbps, SMPTE 259M, SMPTE 292M, SMPTE 424M, SMPTE425M	
Video bandwidth	[2.97Gpbs & 2.97/1.001Gbps]	
Data rates	270 / 1483 / 1485 / 2970 Mbps	
Output impedance	75Ω	
Reclocking function	Yes	
Cable equalization	[3G] up to 90m (300ft) / [HD] up to 150m (500ft) [SD] up to 300m (1000ft)	
Audio support	Yes	
RP-198 pathological patterns	Immune	
Input	1x BNC [SDI]	
Output	6x BNC [SDI]	
Eye pattern characteristics [HD]	Amplitude: Within 800mV (<10%) Rise overshoot: Less than 2% (<10%) Fall overshoot: Less than 2% (<10%) Long time jitter: 0.195 UI (<1.0 UI) Timing jitter: 0.8 UI (<1.0 UI) Alignment jitter: 0.13 UI (<0.2 UI)	
Mechanical		
Housing	Metal enclosure	
Dimensions [L x W x H]	Model	105 x 78 x 27mm [4.1" x 3" x 1"]
	Package	270 x 175 x 80mm [10.6" x 6.9" x 3.2"]
	Carton	450 x 370x 300mm [1'5.7" x 1'2.6" x 11.8"]
Weight	Model: 310g [10.9oz] / Package: 785g [1.7lbs]	
Power supply	5VDC 4A with locking connector	
Power consumption	5 Watts [max]	
Operation temperature	0~40°C [32~104°F]	
Storage temperature	-20~60°C [-4~140°F]	
Relative humidity	20~90% RH [no condensation]	

PANEL DESCRIPTIONS

Front Panel

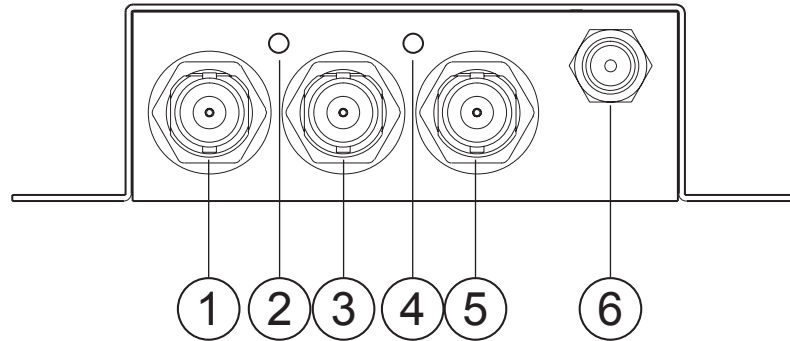

Rear Panel

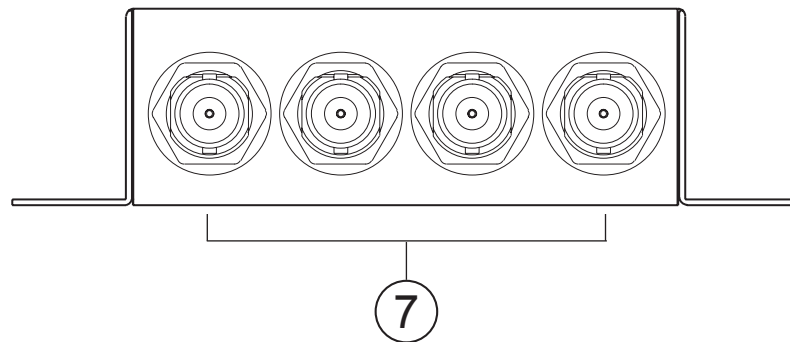

1. **3G/HD/SD-SDI input**
2. **LED** - Orange: SD, Green: 3G/HD
3. **3G/HD/SD-SDI output**
4. **LED** - Orange: Power indicator, Green: signal detected
5. **3G/HD/SD-SDI output**
6. **5V DC power jack**
7. **3G/HD/SD-SDI output**

HARDWARE INSTALLATION

1. Connect a camera or other device equipped with 3G/HD/SD-SDI outputs to VDA-106-3GS 3G/HD/SD-SDI input.
2. Connect devices equipped with 3G/HD/SD-SDI inputs (e.g. monitors or video processors) to SP-3016 3G/HD/SD-SDI outputs.
3. Plug power adapter cable into 5V DC power jack.

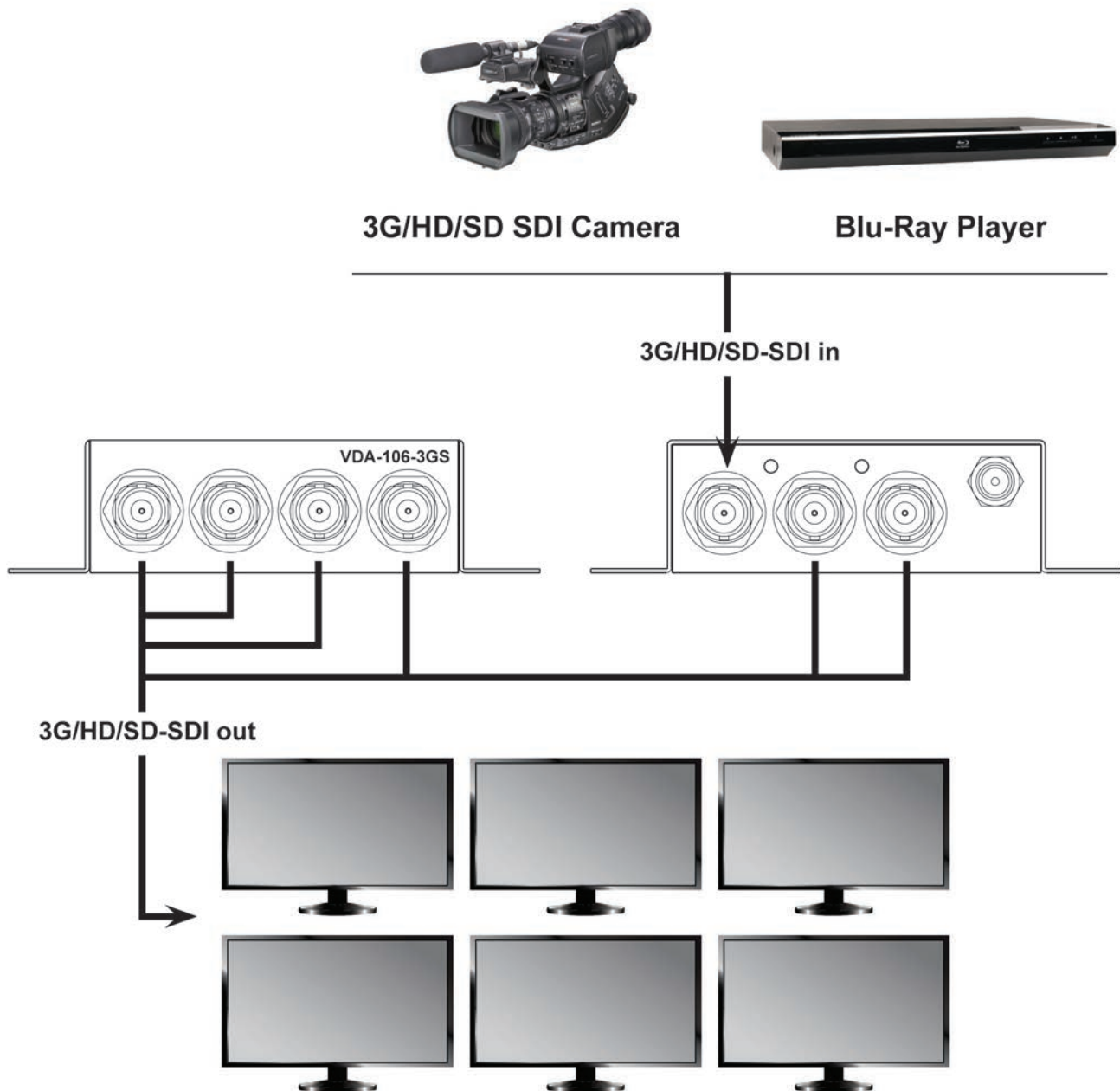

SIGNAL MEASUREMENT

Figure 1



Figure 2



Figures 1 and 2 show actual test results demonstrating extremely low jitter and proper performance with standard pathological test signals. All tests performed using Belden 1694A coaxial cable.

WARRANTY

Marshall Electronics warrants to the first consumer that this VDA-106-3GS, 1x6 3G/HD/SD-SDI Splitter will, under normal use, be free from defects in workmanship and materials, when received in its original container, for a period of one year from the purchase date. This warranty is extended to the first consumer only, and proof of purchase is necessary to honor the warranty. If there is no proof of purchase provided with a warranty claim, Marshall Electronics reserves the right not to honor the warranty set forth above. Therefore, labor and parts may be charged to the consumer.

This warranty does not apply to the product exterior or cosmetics. Misuse, abnormal handling, alterations or modifications in design or construction void this warranty.

No sales personnel of the seller or any other person is authorized to make any warranties other than those described above, or to extend the duration of any warranties on behalf of Marshall Electronics, beyond the time period described above.

Due to constant effort to improve products and product features, specifications may change without notice.

Marshall Electronics, Inc.

1910 East Maple Ave. El Segundo, CA 90245

Tel: (800) 800-6608 / (310) 333-0606 • Fax: 310-333-0688

www.LCDracks.com

support@marshall-usa.com