

TelePad™ iPhone mic stand adapter

USER GUIDE

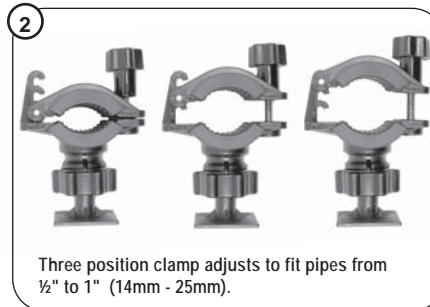
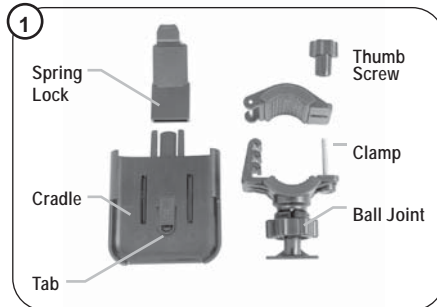

1588 Kebet Way, Port Coquitlam,
British Columbia, Canada V3C 5M5
Tel: 604-942-1001 • Fax: 604-942-1010
Email: info@primacoustic.com

Primacoustic is a division of Radial Engineering Ltd.
TelePad User Guide #R870 2061 00. Specifications and
appearance subject to change without notice.
Copyright 2010, all rights reserved.

www.primacoustic.com

LIMITED WARRANTY

LIMITED 30 DAY WARRANTY Primacoustic products are guaranteed to be free of manufacturing defects for a period of thirty (30) days after purchase. In the unlikely event that a defect is uncovered, please email info@primacoustic.com or call 604-942-1001 to obtain a return authorization number (RA#) from Primacoustic before the thirty (30) day warranty period expires. Once you have obtained an RA number return the product, freight prepaid, within fifteen (15) days after the date the RA number is issued. In the original packaging (or another, affording an equal degree of protection) with all of the following: (1) RA number clearly marked on the returned package; (2) a copy of the original bill of sale showing proof of purchase from an authorized retail seller; and (3) a written note describing the defect including your name, address, telephone number, email address and the applicable RA number. You are solely responsible for all shipping and insurance costs for returning the product to Primacoustic, and you will not be reimbursed or compensated for any loss or damage incurred. Primacoustic will at its discretion repair or replace the product. Should the product be no longer available, Primacoustic reserves the right to exchange this with a product of similar performance and value. Due to different dye lots, Primacoustic cannot guarantee exact color match. This Warranty shall solely extend to the original owner and is limited to manufacturing defects only and excludes damage due to improper installation, freight handling, wear and tear, abuse, misuse, misapplication, color fading or deterioration due to prolonged exposure to ultra violet light, smoke, humidity or other environmental factors. It is understood that the use and suitability of the product is entirely the responsibility of the buyer or specifying engineer and as such, these parties agree to hold Primacoustic, or its associated company, and/or officers, harmless from any responsibility whatsoever other than what is clearly outlined in this warranty. This warranty gives you specific legal rights, and you may also have other rights, which may vary depending on where you live and where the product was purchased.