

Model SS-1002

Single-Channel Intercom Speaker Station

Models SS-2002

Two-Channel Intercom Speaker Station

Model SS-2002 RM

Two-Channel Rack Mount Intercom Speaker Station

Technical Manual



PROPRIETARY NOTICE

The product information and design disclosed herein were originated by and are the property of Bosch Security Systems, Inc. Bosch reserves all patent, proprietary design, manufacturing, reproduction, use and sales rights thereto, and to any article disclosed therein, except to the extent rights are expressly granted to others.

COPYRIGHT NOTICE

Copyright 2010 by Bosch Security Systems, Inc. All rights reserved. Reproduction, in whole or in part, without prior written permission from Bosch is prohibited.

WARRANTY AND SERVICE INFORMATION

For warranty and service information, refer to the appropriate web site below:

RTSwww.rtsintercoms.com/warranty

RTSTWwww.rtstw.com/warranty

AudioComwww.telexaudiocom.com/warranty

RadioComwww.telexradiocom.com/warranty

Headsetswww.intercomheadsets.com/warranty

CUSTOMER SUPPORT

Technical questions should be directed to:

Customer Service Department
 Bosch Security Systems, Inc.
 12000 Portland Avenue South
 Burnsville, MN 55337 USA
 Telephone: 877-863-4169
 Fax: 800-323-0498
 Info@rtsintercoms.com

Technical Questions EMEA
 Bosch Security Systems Technical Support EMEA
 http://www.rtsintercoms.com/contact_main.php

FCC Statement

This equipment uses, and can radiate radio frequency energy that may cause interference to radio communications if not installed in accordance with this manual. The equipment has been tested found to comply with the limits of a Class A computing device pursuant to Subpart J Part 15 of FCC Rules which are designed to provide reasonable protection against such interference when operated in a commercial environment. Operation of this equipment in a residential area may cause interference which the user (at his own expense) will be required to correct.

This product meets Electromagnetic Compatibility Directive 89/336/EEC



This package should include the following:



QTY	DESCRIPTION	PART NO.
1	SS-1002, 1 channel front plate assembly OR	9010-7741-000
1	SS-2002, 2 channel front plate assembly	9010-7741-001
1	User Manual	9350-7741-000
4	Screw, Flat Head, 6-32 x 5/16"	51847-122

One of the following, depending on what was ordered:

1	P-box, 1-channel	9010-7627-007
1	S-box, w/handle, 1-channel	9010-7627-008
1	P-box, 2-channel	9010-7627-009
1	S-box, w/handle, 2-channel	9010-7627-010
1	U-box	9010-7627-004
1	S-box, w/out handle, 1-channel	9010-7627-011
1	S-box, w/out handle, 2-channel	9010-7627-012
1	Warranty Card	38110-390
2	End Caps	9310-7620-001
1	Statement of Conformity	38109-675

SS-2002RM

1	SS-2002RM Final Assembly	9010-7742-000
4	Foot, bumper, black	56471-001
1	User Instructions	9350-7741-000
1	Statement of Conformity	38109-675
1	Warranty	38110-390

 THE LIGHTNING FLASH AND ARROWHEAD WITHIN THE TRIANGLE IS A WARNING SIGN ALERTING YOU OF "DANGEROUS VOLTAGE" INSIDE THE PRODUCT.	 CAUTION RISK OF ELECTRIC SHOCK DO NOT OPEN CAUTION: TO REDUCE THE RISK OF ELECTRIC SHOCK, DO NOT REMOVE COVER. NO USER-SERVICABLE PARTS INSIDE. REFER SERVICING TO QUALIFIED SERVICE PERSONNEL.	 THE EXCLAMATION POINT WITHIN THE TRIANGLE IS A WARNING SIGN ALERTING YOU OF IMPORTANT INSTRUCTIONS ACCOMPANYING THE PRODUCT
SEE MARKING ON BOTTOM/BACK OF PRODUCT		

WARNING: APPARATUS SHALL NOT BE EXPOSED TO DRIPPING OR SPLASHING AND NO OBJECTS FILLED WITH LIQUIDS, SUCH AS VASES, SHALL BE PLACED ON THE APPARATUS.

WARNING: THE MAIN POWER PLUG MUST REMAIN READILY OPERABLE

CAUTION: TO REDUCE THE RISK OF ELECTRIC SHOCK, GROUNDING OF THE CENTER PIN OF THIS PLUG MUST BE MAINTAINED.

WARNING: TO REDUCE THE RISK OF FIRE OR ELECTRIC SHOCK, DO NOT EXPOSE THIS APPRATUS TO RAIN OR MOISTURE.

WARNING: TO PREVENT INJURY, THIS APPARATUS MUST BE SECURELY ATTACHED TO THE FLOOR/WALL/RACK IN ACCORDANCE WITH THE INSTALLATION INSTRUCTIONS.

	This product is AC only.
---	--------------------------

Important Safety Instructions

1. Read these instructions.
2. Keep these instructions.
3. Heed all warnings.
4. Follow all instructions.
5. Do not use this apparatus near water.
6. Clean only with dry cloth.
7. Do not block any ventilation openings. Install in accordance with the manufacturer's instructions.
8. Do not install near any heat sources such as radiators, heat registers, stoves, or other apparatus (including amplifiers) that produce heat.
9. Do not defeat the safety purpose of the polarized or grounding-type plug. A polarized plug has two blades with one wider than the other. A grounding type plug has two blades and a third grounding prong. The wide blade or the third prong are provided for your safety. If the provided plug does not fit into your outlet, consult an electrician for replacement of the obsolete outlet.
10. Protect the power cord from being walked on or pinched particularly at plugs, convenience receptacles, and the point where they exit from the apparatus.
11. Only use attachments/accessories specified by the manufacturer.
12. Use only with the cart, stand, tripod, bracket, or table specified by the manufacturer, or sold with the apparatus. When a cart is used, use caution when moving the cart/apparatus combination to avoid injury from tip-over.
13. Unplug this apparatus during lightning storms or when unused for long periods of time.
14. Refer all servicing to qualified service personnel. Servicing is required when the apparatus has been damaged in any way, such as power-supply cord or plug is damaged, liquid has been spilled or objects have fallen into the apparatus, the apparatus has been exposed to rain or moisture, does not operate normally, or has been dropped.

Table of Contents

INTRODUCTION	3
Introduction	3
Description	3
Features	4
INSTALLATION	7
Configuration Pre-check	7
DIP Switches	7
Mic Kill Receive	8
Call Signal Compatibility	8
Incoming Call Beep	8
Microphone Type	8
Speaker Beep for Incoming Call	9
Balanced/Unbalanced Switch	9
Sidetone Trimmers	9
Headset Connector Notes	9
Panel Mic Connector Notes	9
Intercom Channel Connections	10
Description of Phantom-Powered Connection	10
Description of Locally Powered Connection	11
All Locally Powered Intercom Stations (Dry Lines)	12
OPERATION AND SPECIFICATIONS	15
Power Up	15
Sidetone Adjustment	15
Channel Select (SS-2002 & SS-2002RM Only)	16
Headset/Headphone/Speaker/Microphone Selection	16
Receiving Calls	16
Calling an Intercom Channel	17
Specifications	18
Dimensions	19
SS1002/2002 SUPPLEMENTAL INFORMATION	21
Installing the Box to the Faceplate	21
GENERAL INSTRUCTIONS	21
Notes	23

Introduction

Thank you for purchasing the Audiocom SS-1002/2002/2002RM Intercom Speaker Station. We hope the many design features of this product satisfies your intercommunication requirements for many years to come. To get the most out of you new intercom stations, take a few moments to look through this manual before using the Intercom Speaker Stations for the first time.

Description

The Intercom Speaker Stations may be used with a headset, or with the built-in speaker and panel microphone or an optional gooseneck microphone. Another option is to use headphones and either the built-in panel microphone or an optional gooseneck microphone. As an alternative to a headset, a telephone-style handset may also be used.

The SS-1002 is a single-channel station; the SS-2002 & SS-2002RM provide switch selectable access to either of two (2) intercom channels. Both the SS-1002 and the SS-2002 come in three (3) versions to suit a variety of applications.

S Box - The S box is a portable version. It has a carrying handle and dual loop-through intercom connectors which permit stations to be quickly interconnected using pre-fabricated cables.

P Box - The P box is stationary version. It also has dual loop-through connectors for quick interconnection, but the case is designed for desktop or console-mount applications.

U Box - The U box is designed for permanent, in-the-wall mounting. It uses push-type wire terminals for connection to the intercom system.

NOTE: In addition, the SS-2002RM can be used on a desktop or mounted in a standard 19" equipment rack (using the optional RM-14 Rack Mount Kit).

Features

Use Figure 1 and Figure 2 to locate the features described below.

1. *Channel and Power Connections* - The U box uses quick release terminals to connect to audio and power wires. For the S box and P box versions, the terminal connections are connected to the dual, loop-through XLR connectors on the side of the box. These permit several stations to be connected in a string, or daisy-chain, using pre-fabricated intercom cables.
2. *Configuration DIP Switches* - Controls the following features:
 - Call Beep*- In addition to a flashing call key indication for incoming calls, an incoming call beep tone can also be used.
 - Headset Microphone Type Selection*- Either a balanced or unbalanced dynamic microphone can be selected.
 - DC call enable*- This may be turned on to use the intercom station with intercom systems that use DC call signaling.
3. *Panel Mic Key* - Selects the Panel Mic/Built-in Mic connector (11) in the on position, the headset connector (10) in the off position.
4. *Speaker Key* - Selects the built-in speaker in the on position, the headset connector (10) in the off position.
5. *Channel Select Key (SS-2002 & SS-2002RM only)* - Selects intercom channel 1 or 2. The key lights green for channel 1 and red for channel 2
6. *Volume Control* - Adjusts intercom listen volume to headphones or speaker.
7. *Intercom Listen Key* - Both momentary (*also known as push-to-listen*) and latching (*also known as hands-free-listen*) functions are possible.
8. *Call Key* - Use to send call signals on the intercom channel. Flashes for incoming calls.
9. *Intercom Talk Key* - Only the momentary (push-to-talk) function is possible. All models are equipped with a *mic kill receive* circuit, which allows an operator at a remote master station (such as the US-2000A) to turn off the talk key on all stations along the intercom line.
10. *Dynamic-Mic Headset Connector* - 4-pin male XLR connector accepts headsets with monaural headphones and either a balanced or unbalanced dynamic microphone. Also accepts a telephone style handset. It can be used with headphones when a panel mic is connected. A handheld microphone along with the internal speaker can also be used.
11. *Panel Mic Connector* - Accepts an electret gooseneck microphone such as the Telex MCP-90.
12. *Built-in Panel Microphone* - Active when the Panel Mic key is pressed and a gooseneck microphone is not inserted in the Panel Mic connector.

13. *Sidetone Trimmers* -

The sidetone trimmers adjust the level of the user's own voice in the headphones when using full-cushion headphones. When using the speaker or open-ear style headphones, the sidetone trimmers are adjusted to eliminate the user's voice from the headphones or speaker. This helps to prevent feedback.

14. *Balanced/Unbalanced Selector Switch* -

This switch sets the intercom station for compatibility with either Audiocom (balanced) or Clear-Com (unbalanced) intercom systems.

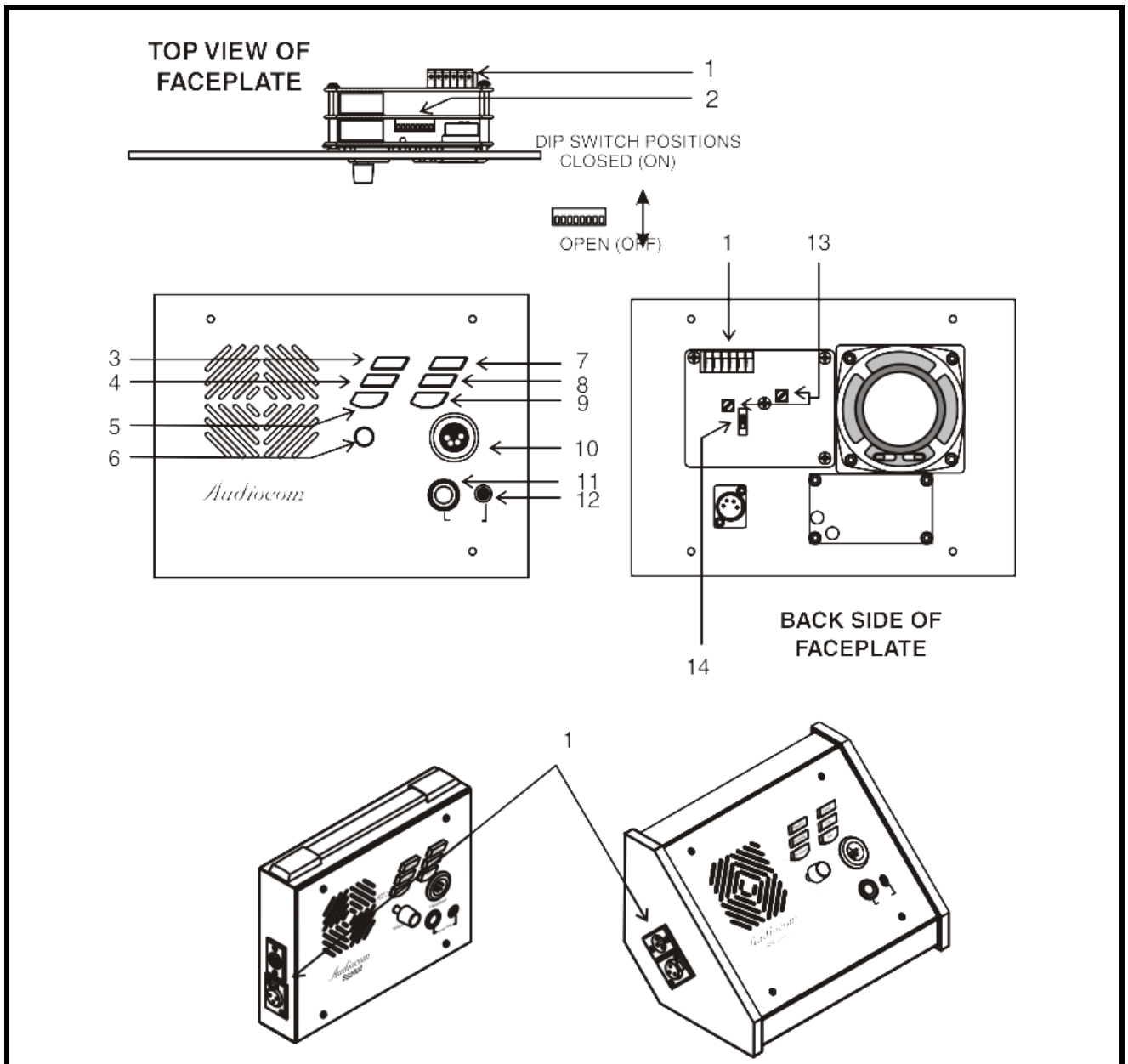

FIGURE 1. SS-1002/2002 Features

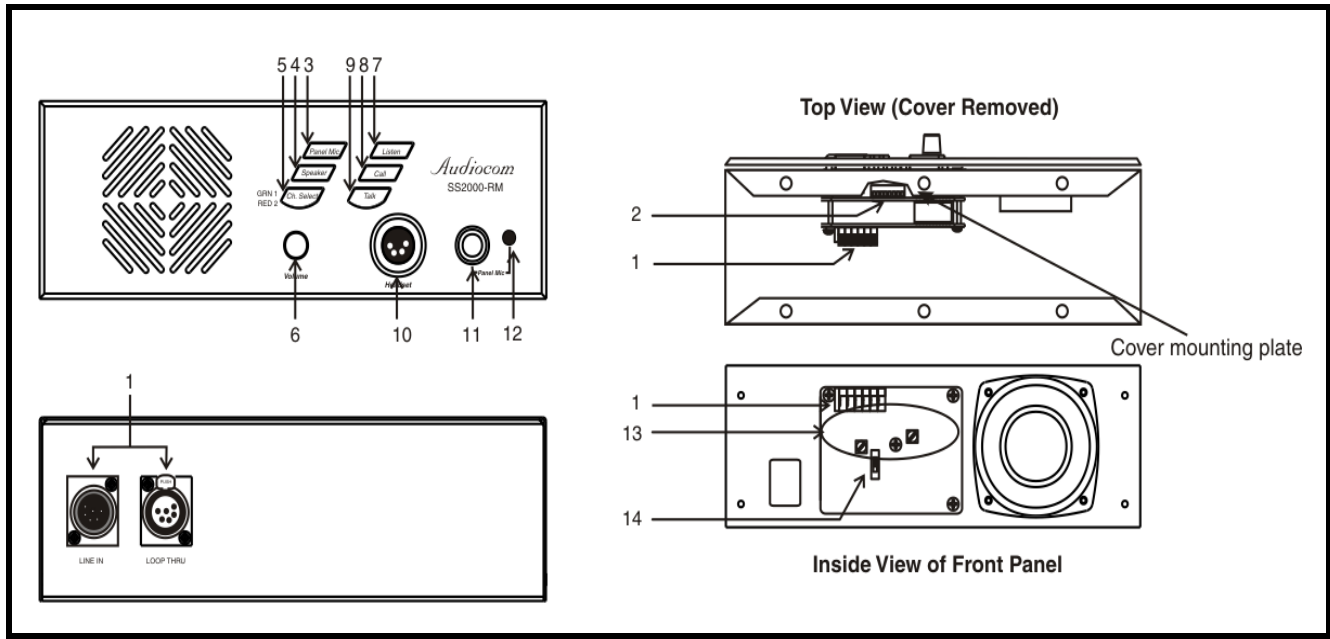

FIGURE 2. SS-2002RM Features

Configuration Pre-check

Before making connections, read the following configuration notes. Make sure all internal controls are properly set for your intended usage.

To **access the internal controls**, do the following:

1. Remove the **four (4) screws** on the front panel that secure the intercom station faceplate to the mounting box.
2. Pull the **faceplate** out for all versions (except the RM version).

To **access the internal controls for the RM version**, do the following:

1. Remove the **10 screws** securing the cover on the box.
2. Lift the **cover** off.

DIP Switches

TABLE 1. DIP Switch descriptions and factory default settings

Switch Number	Description	Settings Open = OFF; Closed = ON	Default Settings
1	Mic Kill Receive	Closed: Disabled, No Mic Kill Open: Enabled, Mic Kill Active	Open
2	Call Signal Method	Closed: DC (SW1 set to UNBAL) Open: Audiocom (SW1 set to BAL)	Open
3	Incoming Call Beep	Closed: Disabled Open: Enabled	Open
4	Microphone Type	Closed: Unbalanced Open: Balanced	Open
5	Speaker Beep for Incoming Call	Closed: Enabled (DIP switch 3 must be set to Open) Open: Disabled	Open
6	Not Used	Not Defined	Open
7	Not Used	Not Defined	Open
8	Not Used	Not Defined	Open

Mic Kill Receive

Audiocom intercom stations, such as the US2002A, can transmit an inaudible signal to turn off the microphones in all remote intercom stations on an intercom channel. This is useful when a remote intercom station has been left unattended with the microphone on. The procedure to send a mic kill signal from a master station is a two-step process, so it is very unlikely microphones are ever turned off by accident. However, you may wish to disable the Mic Kill Receive feature at the intercom unit. You might do this, for example, if communications are of a very critical nature, where it is absolutely essential the microphone never be remotely deactivated.

To **enable the mic kill function**, do the following:

- > Set **DIP switch 1** to the open position.

To **disable the mic kill function**, do the following:

- > Set **DIP switch 1** to the closed position.

Call Signal Compatibility

For **Audiocom setup**, do the following:

1. Verify **Dip Switch 2** is in the OPEN position.
2. Verify the **Balanced/Unbalanced switch** is in the Balanced position.

For **Clear-Com setup**, do the following:

1. Set **DIP switch 2** to the CLOSED position.
2. Set the **Balanced/Unbalanced switch** to the Unbalanced position.

Incoming Call Beep

Incoming calls are always indicated by a red flashing call key.

To **set the incoming call beep in the headphones**, do the following:

- > Set **DIP switch 3** to the OPEN position (default).
DIP switch 3 must also be in the OPEN position if you want to activate incoming call beep to the speaker using DIP switch 5.

Microphone Type

If you are using a headset, telephone handset, or dynamic handheld microphone:

If the **specifications indicate the microphone type is balanced**, do the following:

- > Set **DIP switch 4** in the open (default) position.

If the **specifications indicated an unbalanced microphone**, do the following:

- > Set this **switch** to the closed position.

NOTE: If you are not sure, leave the switch in the open position for now. Try both positions during operations. Use the position that produces the best audio quality at other stations.

Speaker Beep for Incoming Call

To **set the speaker beep for incoming calls**, do the following:

- > Set **DIP switch 5** to the closed position if you want to hear incoming call beep in the speaker.

NOTE: DIP switch 3 must be in the open position.

Balanced/Unbalanced Switch

This switch is set at the factory to the Balanced (BAL) position for use with Audiocom intercom systems. Set the switch to the Unbalanced, or UNBAL position for use with a Clear-Com intercom system.

Sidetone Trimmers

The **Sidetone Trimmers** are normally adjusted after all connections are completed. See “Sidetone Adjustment” on page 15.

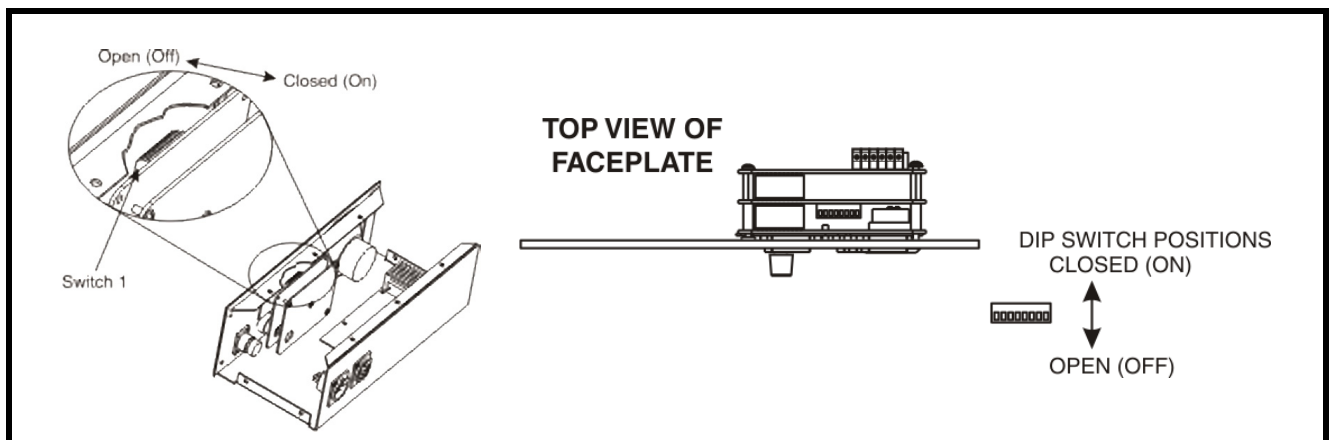

FIGURE 3. DIP Switch location RM version (left), SIP switch location S, U, and P Versions (right).

Headset Connector Notes

If you are using a monaural, dynamic-mic headset, or a monaural, telephone-style, dynamic-mic hands-free, or a handheld dynamic microphone, plug it into the headset connector. You can also use this connector with monaural headphones for listening when you are using either the built-in panel microphone or the optional gooseneck microphone for talk back.

Panel Mic Connector Notes

As an alternative to a headset or telephone style handset, you can use either the built-in panel microphone or an optional gooseneck microphone.

To **connect a Telex MCP-90 gooseneck microphone**, do the following:

1. Insert the **1/4" RTS connector** into the panel microphone connector.
2. Screw the **microphone** in.

When a gooseneck microphone is inserted in the panel microphone connector, the built-in panel microphone is automatically bypassed. Use either of these microphones for talk back, then use the internal speaker for listening, or connect a pair of headphones to the headset connector for private listening.

Intercom Channel Connections

The method of connection depends on the type of box. The S box, P box, and RM versions connect to the intercom system using pre-fabricated cables in a phantom powered configuration. The U box version is designed for permanent installation, and it can be either phantom powered or locally powered.

Description of Phantom-Powered Connection

In phantom-powered connections the operating power and intercom audio for the entire system are carried over the same wires. The advantage of this method is simplicity of connection. The system power supply (PS-2001L, SPS-2001A, etc.) automatically provides what is known as a terminating impedance for the intercom system. Without this terminating impedance, the sound quality becomes distorted, and the levels shift every time additional stations are connected. The disadvantage of the phantom power method is some operating power is lost over very long intercom cable runs, and performance at distant intercom station may be reduced. Generally, if intercom stations are within a few hundred feet from the system power supply, phantom power is sufficient. Also, increasing the number of stations reduces the overall operating distance. Phantom-power is generally the only method used to connect the S box, P box, and RM versions. Figure 4 illustrates a phantom-power intercom system.

NOTE: The distance over which power can be delivered is less than the distance over which audio can be delivered. Audio can be delivered for several miles to locally powered stations as described below.

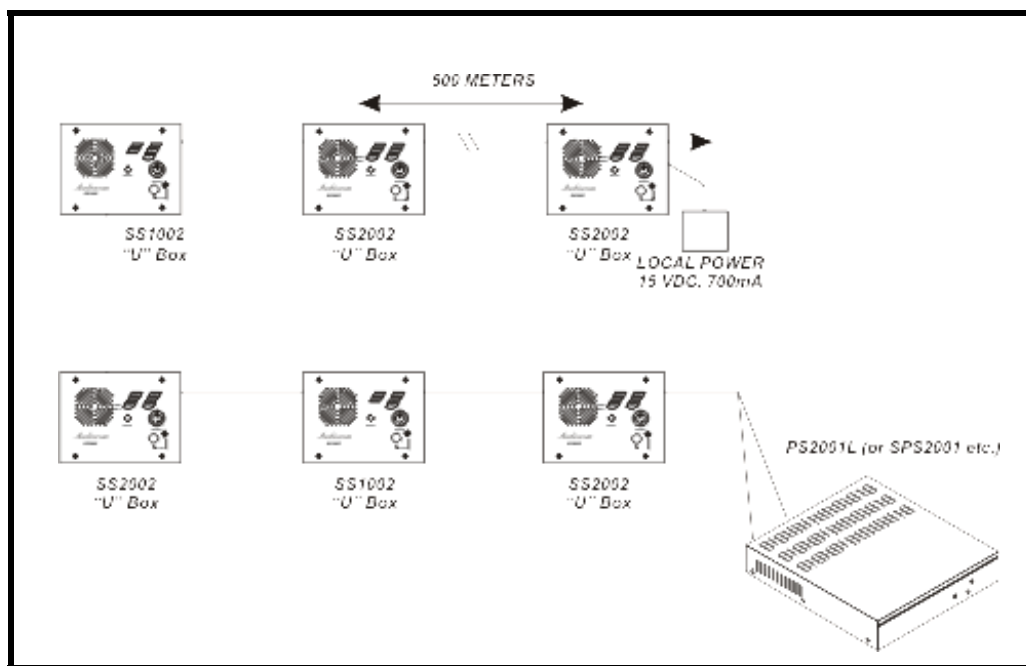

FIGURE 4. Phantom Powered Example

Example: Figure 4 is an example of a phantom-powered system. In this system, a PS-2001L power supply is set to isolate mode. Each channel is a separate party line and current per channel is limited to 1Amp. Both single and two-channel intercom stations may be connected by using Y cables (or JB2 Junction boxes). Pre-fabricated cables may be used, or cables may be constructed using the diagrams in Figure 10 on page 14.

Description of Locally Powered Connection

Using a Locally Powered Connection, an intercom station is connected to the intercom line just like any phantom powered intercom station, except a local power supply is also connected. The external local power supply is located near the intercom station and provides power for that station only.

Since power loss on the intercom lines is no longer an issue, the operating range is now limited only to the audio transmission range, which is several miles. Another advantage to this method is more stations can be connected to the intercom channels. When local power is supplied to an intercom station, the station detects it and automatically disconnects from the system's phantom-power supply.

Figure illustrates an intercom system with both phantom-powered and locally powered U boxes. As long as a system power supply (PS2001L, SPS-2001, etc.) is located somewhere in the intercom system, the proper terminating impedance is still be supplied for all stations. However, if all stations are locally powered, and there is not system power supply, a special line termination must be installed.

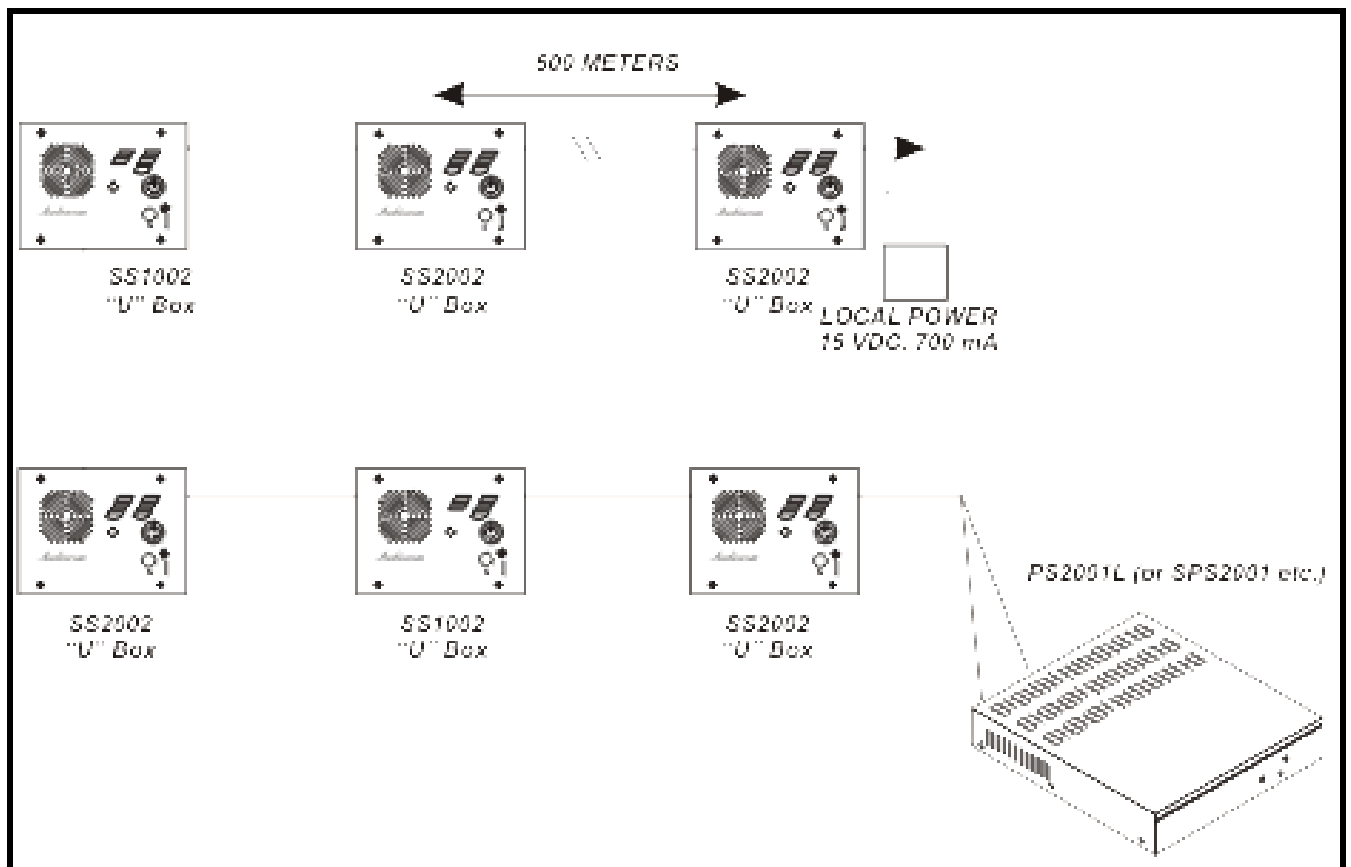

FIGURE 5. A 2-channel Audiocom intercom system using a PS2001L power supply.

A 2-channel Audiocom intercom system using a PS2001L power supply (as shown in Figure 5). The PS2001L is set to isolate mode. In isolate mode, each intercom channel is a separate party line, and total current for each channel is limited to 1 Amp. Both the SS-1002 and SS-2002 stations may be connected depending on each location's need to communicate with one or two channels. SS-1002 stations may be connected to either channel one or two. Also, note locally powered stations may be connected. This is recommended when stations are installed at remote locations. Since the PS2001L provides termination for the intercom channels, no user-installed termination is required.

All Locally Powered Intercom Stations (Dry Lines)

If intercom stations are widely distributed, you can dispense with a system power supply (PS2001L, SPS-2001, etc.) and use local power for each station. When no power is delivered on the intercom channels, this is known as dry-line operation. Since a system power supply is not used, a line termination must be inserted in each intercom channel for proper operation. Again, not that only the U box has provisions for local power, the 3-pin connectors on the S, P, and RM version do not permit this type of connection. Figure illustrates an intercom system using all locally powered U boxes.

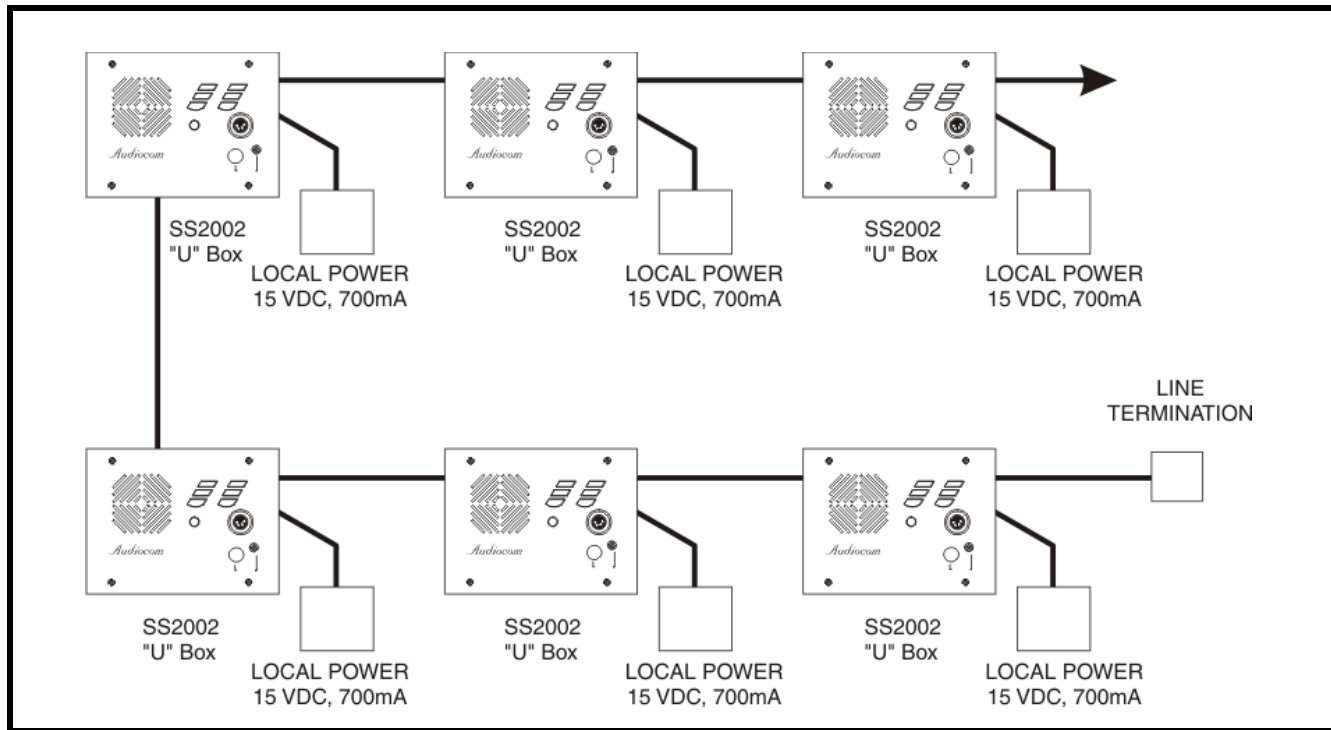

FIGURE 6. Intercom system using all locally powered U box stations.

An example (as shown in Figure 6) of an Audiocom intercom system using all locally powered U box stations, with no power being distributed on the intercom channels (dry lines). Since an Audiocom power supply is not used, the installer must connect a line termination somewhere in each channel for proper operation.

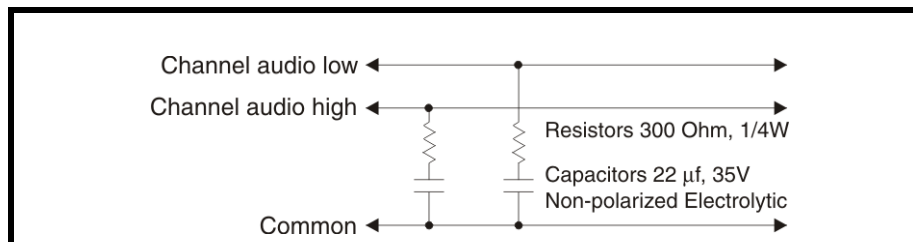

FIGURE 7. Audiocom mode line termination for dry-line operation. (One required for each channel). The termination is available via P/N 9020-7550-000.

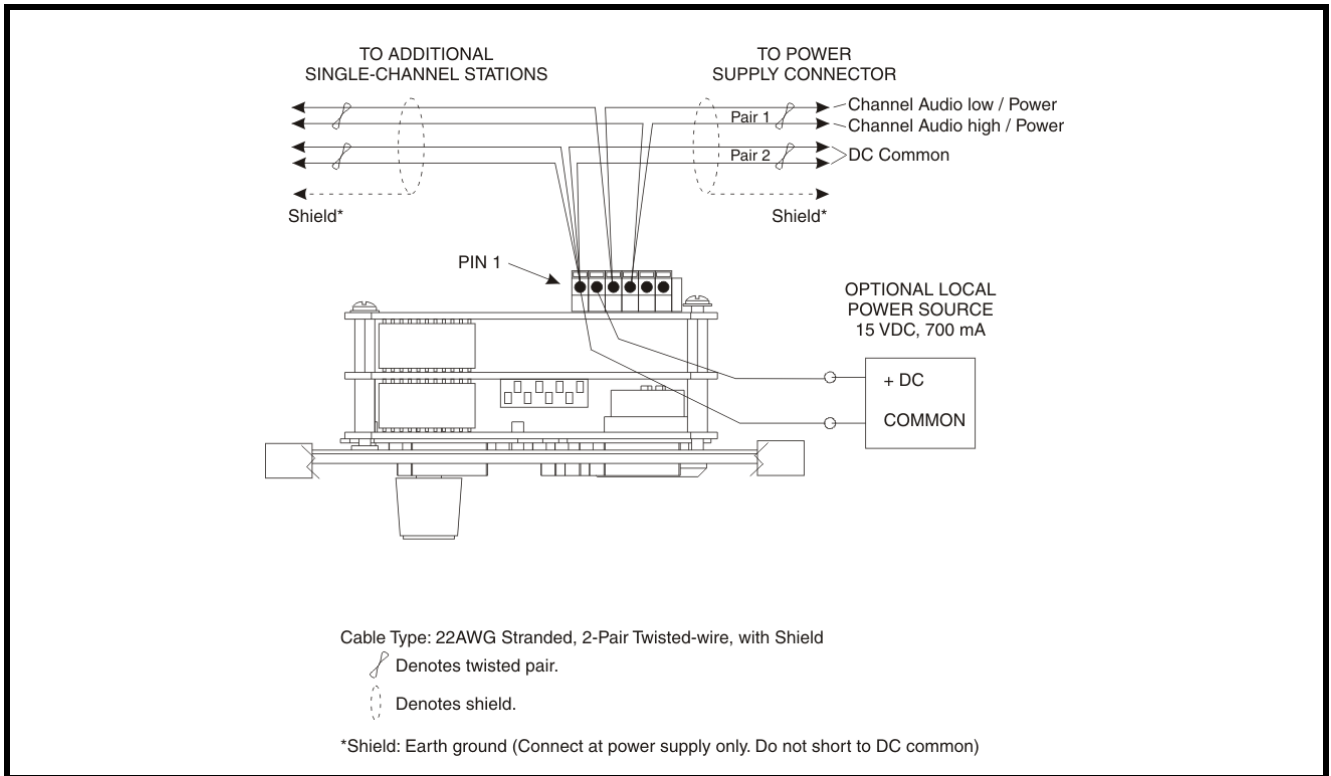

FIGURE 8. Audiocom mode connections for an SS-1002 Intercom Station in a U box. For Clear-Com connection, use the *Unbalanced Mode Intercom Channel* pin out information listed in “Specifications” on page 18.

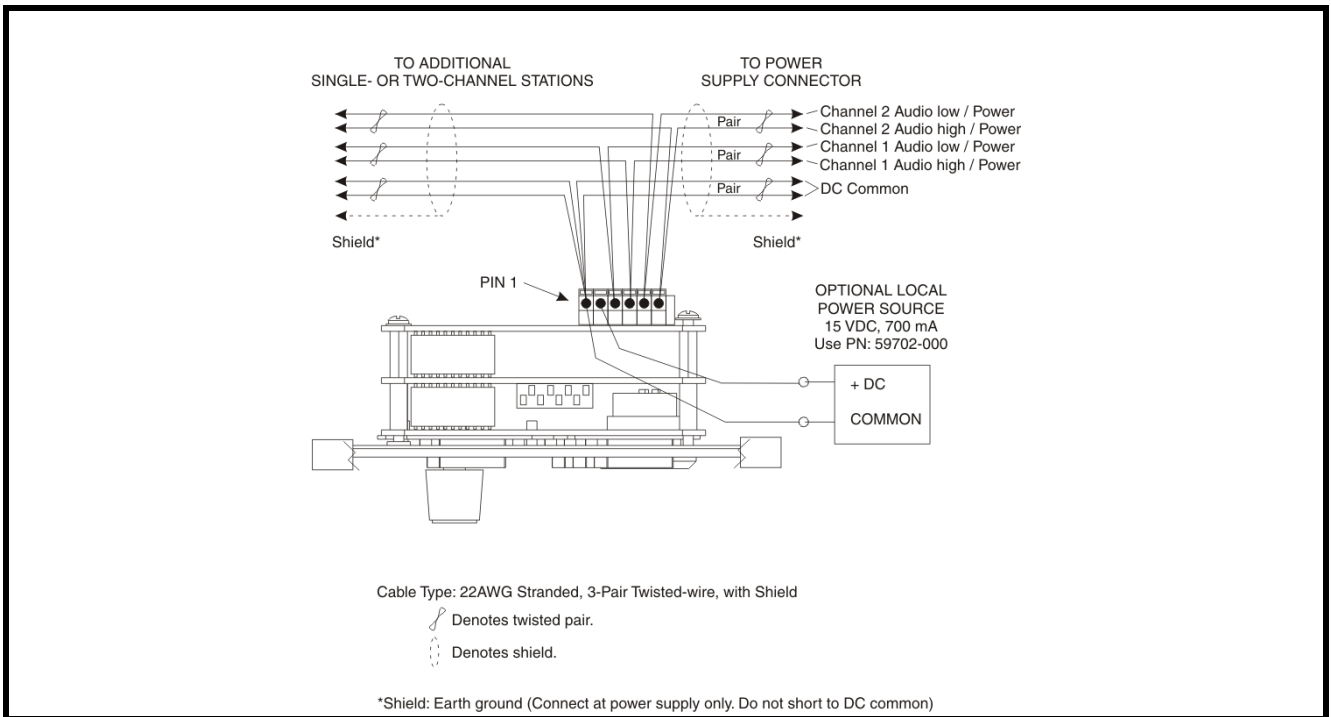
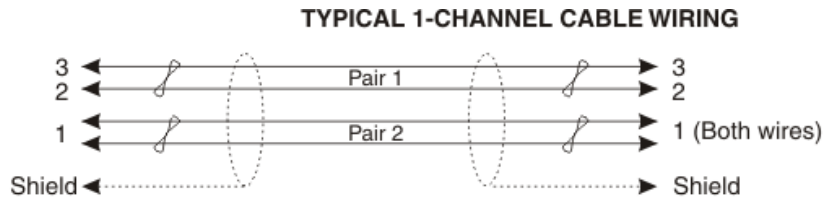

FIGURE 9. Audiocom mode connections for an SS-2002 Intercom Station in a U box. For Clear-Com connection, use the *Unbalanced Mode Intercom Channel* pin out information listed in “Specifications” on page 18.



Cable Type: 22AWG Stranded, 2-Pair Twisted-wire, with Shield

Connector Type: 3-Pin XLR Audio (Neutrik or Switchcraft)*

Pin 1: Common

Pin 2: Channel Audio / Power

Pin 3: Channel Audio / Power

Shield: Earth ground

Denotes twisted pair.

Denotes shield.

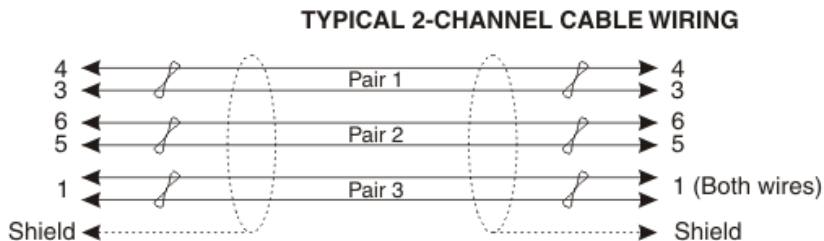

Cable Type: 22AWG Stranded, 3-Pair Twisted-wire, with Shield

Connector Type: 6-Pin XLR Audio (Neutrik only, not compatible with 6-pin Switchcraft)*

Pin 1: Channel 1 & 2 Common

Pin 2: No connection

Pin 3: Channel 1 Audio / Power

Pin 4: Channel 1 Audio / Power

Pin 5: Channel 2 Audio / Power

Pin 6: Channel 2 Audio / Power

Shield: Earth ground

Denotes twisted pair.

Denotes shield.

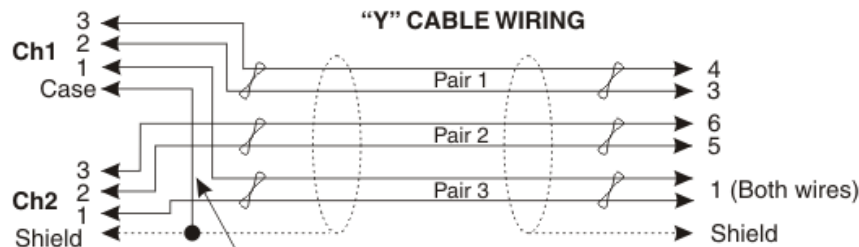

Use second drain wire if available, or add an extra section of wire.

* Standard cables are generally constructed using a male connector at one end and a female connector at the other end. This allows several cables to be interconnected to create longer cable runs. Audiocom master stations, speaker stations and belt packs also typically provide both a male and female Neutrik connector for each intercom channel. This permits loop-through connection of several intercom stations using the standard cables. Audiocom power supplies use a 3-pin male Neutrik connector for each channel. Audiocom wallplates use male Neutrik connectors.

FIGURE 10. Audiocom cable wiring diagrams

Operation and Specifications

Power Up

To **power up the SS1002/2002**, do the following:

1. Verify the local power supplies are **plugged in**.
2. Turn **on** the power switches of any phantom power supplies (PS-2001L, SPS-2001, etc.).

Sidetone Adjustment

The SS-1002/2002 and the SS-2002RM use full-duplex audio in which the talk and listen audio are sent and received on the same wires when using a headset. The SS1002/2002 and the SS-2002RM use half-duplex audio when the speaker is used. A certain amount of your own voice level is desirable (called sidetone) to overcome the muffled sensation when talking. The sidetone adjustment is different for these operating conditions:

To **adjust sidetone using an open-ear style headset or headphones**, do the following

SS-2002 & SS-2002RM only:

1. Activate **channel 1** as described in “Channel Select (SS-2002 & SS-2002RM Only)” on page 16.
2. Activate **talk and listen** as described in the operating instructions.
3. Slowly increase the **volume to maximum** while talking into the microphone.
4. Using a small, flat-head screwdriver, adjust the **channel 1 sidetone trimmer** to minimize your voice level in the headphones.
5. Activate **channel 2**.
6. Repeat the **steps 1 through 5** to adjust the channel 2 sidetone.
7. Install the **intercom station mounting screws** after completing the adjustments.
The stations is now ready for use.

To **adjust sidetone on SS-2002 and SS-2002RM headphones**, do the following:

1. Activate **channel 1**.
2. Activate **talk and listen**.
3. Set the volume control to the **normal listening level** for intercom audio.
4. While talking into the microphone, use a small, flat-head screwdriver to adjust the **channel 1 sidetone trimmer** so you can hear your own voice in the headphones at an acceptable level.
5. Activate **channel 2**.
6. Repeat the **steps 1 - 5** to adjust the channel 2 sidetone.

Channel Select (SS-2002 & SS-2002RM Only)

To **select a channel on the SS-2002 and SS2002RM**, do the following:

- > Tap the **Ch Select** key to select channel 1 or 2.
The key is green when channel 1 is selected and red when channel 2 is selected.

Headset/Headphone/Speaker/Microphone Selection

- To **use a headset or telephone style handset**:
set the Speaker and Panel Mic keys to **off**.
- To **use headphones with the built-in panel microphone**:
set the speaker key to **off**.
set the panel mic key to **on**.
make sure a **gooseneck microphone is not inserted in the panel microphone connector**.
- To **use headphones with a gooseneck microphone**,
set the speaker key to **off**.
set the panel mic key to **on**.
make sure a **gooseneck microphone is inserted in the panel microphone connector**.
- To **use the speaker with a handheld dynamic microphone**:
set the speaker key to **on**.
set the panel mic key to **off**.
- To **use the speaker with the built-in panel microphone**:
set the speaker and panel mic keys to **on**.
make sure a gooseneck microphone is **not inserted in the panel microphone connector**.
- To **use the speaker with a gooseneck microphone**:
set the speaker and panel mic keys to **on**.
make sure a **gooseneck microphone is inserted in the panel microphone connector**.

Receiving Calls

When there is an incoming call signal, the call key flashes red. There is a beep tone in the headphones or speaker if the beep feature is activated.

NOTE: The incoming call indication is provided only for the currently selected intercom channel in the case of SS-2002 & SS-2002RM models.

To **receive calls**, do the following:

-
1. Turn **ON** the listen keys and begin your conversation.
 2. Turn the keys **OFF** when finished.

NOTE: You can turn the listen key on in either momentary or latched mode. For momentary operations, press and hold the key. For latched operation, tap the key to turn it on. Then tap it again to turn it off when finished. You can turn the talk key on in momentary mode only.

Calling an Intercom Channel

To **call an intercom channel from the SS-2002 or SS-2002RM**, do the following:

1. Select the **desired intercom channel**.
2. Press and hold the **Call** key.
An inaudible call signal is sent, and the Listen key automatically turns ON.
3. When you hear a response, release the **Call** key and activate the **Talk** key.
4. Turn **OFF** the Listen key to end the conversation.

Specifications

General

Power Requirements

Phantom Power: +24VDC nominal, 75mA without speaker; 700mA with Speaker

Local Power: +15VDC, 75mA without speaker; 700mA with Speaker

Dimensions

See Dimensions Drawings (Figure 11 on page 19)

Environmental Requirements

Storage:

-20° C to 80° C; 0% to 95% RH, non-condensing

Operating:

0° C to 50° C; 0% to 95% RH, non-condensing

Dynamic-mic Headset/Handset

Microphones

50 to 200 Ohms, dynamic (balanced or unbalanced)

Headphones

150 to 600 Ohm, monaural

Connector Type: XLR-4M

Pin 1 - Microphone Low

Pin 2 - Microphone High

Pin 3 - Headphone High

Pin 4 - Headphone Low

Panel Microphone

Built-in Microphone

2.2k Ohms, electret (44mV nominal),
Omnidirectional

Gooseneck Microphone

Connector Type: 1/4" Threaded TRS, 5k Ohms,
electret (44mV nominal)

Tip Microphone High (+12VDC)

Ring Common

Sleeve Common

Compatible with MCP-90 Series Microphones

Intercom Channels, Balanced Mode (SW1 set to BAL position)

Output Level

1VRMS nominal

Input Impedance

300 Ohms

Bridging Impedance

greater than 5k Ohms

Sidetone

20dB adjustable range

Call Signaling

Send

20kHz \pm 100Hz, 0.5VRMS \pm 10%

Receive

20kHz \pm 800Hz, 100mVRMS

Mic Kill Detect Frequency

24kHz \pm 800Hz, 100mVRMS

Noise Contribution

less than -70dB

Common Mode Rejection Ratio

greater than 50dB

Connector Type:

Six-position push type terminal block

Pin 1 - Audio and DC Common

Pin 2 - Local power (+12 to +15VDC), if needed

Pin 3 - Intercom CH1 audio low and +24VDC power

Pin 4 - Intercom CH1 audio high and +24VDC power

Pin 5 - Intercom CH2 audio low and +24VDC power

Pin 6 - Intercom CH2 audio high and +24VDC power

Intercom Channels, Unbalanced Mode (SW1 set to UNBAL position)

Output Level

0.775VRMS \pm 10%

Input Impedance

200 Ohms

Bridging Impedance

greater than 5k Ohms

Sidetone

-40dB, 20dB adjustable range

Connector Type:

Six-position push type terminal block

Pin 1 - Ground

Pin 2 - +30VDC

Pin 3 - CH B Intercom

Pin 4 - CH A Intercom

Pin 5 - NC

Pin 6 - NC

Speaker Output Power

4W max @ 8 Ohms

Dimensions

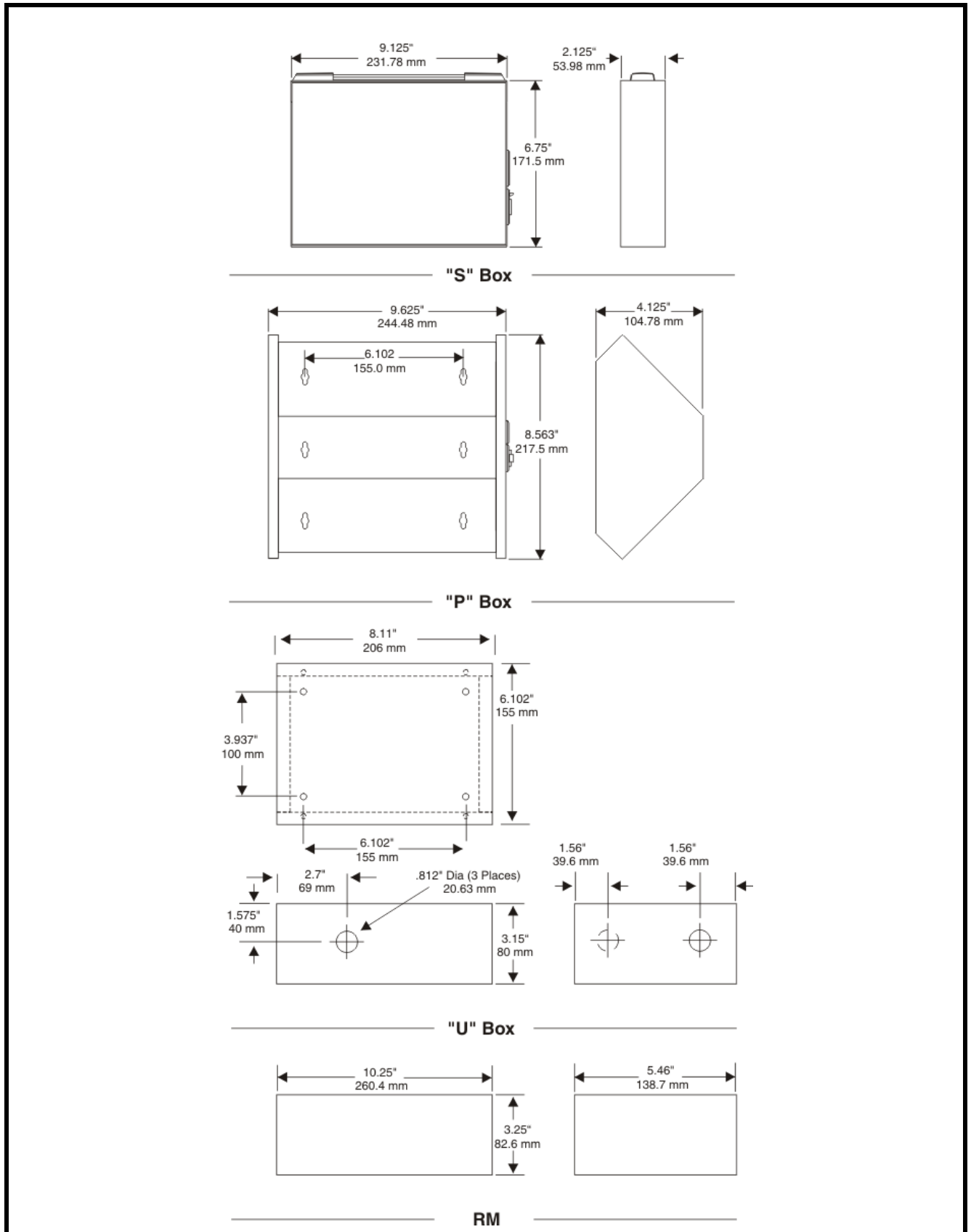

FIGURE 11. Dimensions

SS1002/2002 Supplemental Information

Installing the Box to the Faceplate

General Instructions

If you ordered SS1002/2002 boxes and faceplates separately, use these instructions to assemble the speaker stations. Once you have assembled the stations, refer to the User Manual for all installation and operation information.

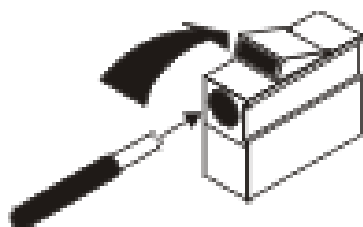

Step 1. Connecting the Wires from the Box to the Faceplate

Use the appropriate pin connections, see Table X, to connect the wires from the XLR audio connector on the box to the terminal strip on the circuit board. (Or, in the case of the U box, connect wires from the intercom system to the terminal strip.) To insert a wire into the terminal strip, push back the green lever on the top of the terminal, as shown, then insert the wire and release the lever.

TABLE 2. SS1002 wire connections for use in Audiocom System

XLR Connector on Box	Terminal Strip on Circuit Board	Description
Pin 1	TB1-1	DC Common
Pin 2	TB1-3	Audiocom Channel audio low and +24VDC phantom power
Pin 3	TB1-4	Audiocom Channel audio high and +24VDC phantom power

TABLE 3. SS1002 wire connections for use in Clear-com System

XLR Connector on Box	Terminal Strip on Circuit Board	Description
Pin 1	TB1-1	Common
Pin 2	TB1-3	Clear-com power input
Pin 3	TB1-4	Clear-com audio / call signal

TABLE 4. SS2002 Wire Connection for use in Audiocom System

XLR Connector on Box	Terminal Strip on Circuit Board	Description
Pin 1	TB1-1	Common
Pin 2	No connection	
Pin 3	TB1-3	Audiocom Channel 1 audio low and +24VDC phantom power
Pin 4	TB1-4	Audiocom Channel 1 audio high and +24VDC phantom power
Pin 5	TB1-5	Audiocom Channel 2 audio low and +24VDC phantom power
Pin 6	TB1-6	Audiocom Channel 2 audio high and +24VDC phantom power

TABLE 5. SS2002 Wire Connections for use in Clear-com System

XLR Connector on Box	Terminal Strip on Circuit Board	Description
Pin 1	TB1-1	Common
Pin 2	TB1-3	Clear-com power input
Pin 3	TB1-6	Clear-com Line B ¹
Pin 4	TB1-4	Clear-com Line A ¹
Pin 5	No Connection	
Pin 6	No Connection	

1. When connected as shown, Clear-com Line A corresponds to SS2002 Ch 1 and Clear-com Line B corresponds to SS2002 Ch 2.

Step 2. Assemble the Faceplate to the Box

Use the four (4) screws supplied with the faceplate.

Step 3. Install the Intercom Station

Refer to the User Instructions for further information.

