

Warranty Registration:
register online today for
a chance to win a FREE Tripp Lite
product—www.tripplite.com/warranty



Owner's Manual

Power Distribution Center

Model: SUDC208V42P

Note: This product requires Output Breakers and Cord Sets, sold separately. See Section 5.1 for ordering information.



1 – Introduction	2
2 – Important Safety Instructions	2
3 – Features	4
4 – Cabinet Installation	5
4.1 Preparation	5
4.2 Unpacking	5
4.3 Placement	6
4.4 Leveling	6
4.5 Ground Connection	7
5 – Wiring Installation	7
5.1 Preparation	7
5.2 Installing Breakers	9
5.3 Installing Cord Sets	9
5.4 Wiring Breakers	10
5.5 Wiring Input Power	11
5.6 Powering Up	11
5.7 Powering Down	11
6 – Storage & Service	12
7 – Warranty and Warranty Registration	12



1111 W. 35th Street, Chicago, IL 60609 USA
www.tripplite.com/support

Copyright © 2010 Tripp Lite. All rights reserved.

1 – Introduction

Tripp Lite's SUDC208V42P Power Distribution Center accepts 3-phase input power from 120/208V, 20-60kVA UPS systems and distributes single-phase and 3-phase output power to your data center's equipment racks. Power distribution through individual breakers and corresponding cord sets maximizes flexibility, balances critical loads and provides branch circuit over-current protection.

2 – Important Safety Instructions



SAVE THESE INSTRUCTIONS

All sections of this manual contain instructions and warnings that must be followed during the installation and operation of the product described in this manual. Read ALL instructions before attempting to move, install or wire this product. Failure to comply may invalidate the warranty and cause serious property damage and/or personal injury.

Location Warnings

- Install the Distribution Center in a controlled indoor environment, away from moisture, temperature extremes, flammable liquids and gasses, conductive contaminants, dust and direct sunlight.
- Operate the Distribution Center at indoor temperatures between 32° F and 104° F (0° C and 40° C) only.
- Allow adequate clearance around the Distribution Center for ventilation, maintenance and easy access to internal devices. Do not block, cover or insert objects into the external ventilation openings.
- Do not place any object on the Distribution Center, especially containers of liquid.
- Do not attempt to stack the Distribution Center. Attempting to stack the Distribution Center may cause permanent damage and create a potential for serious personal injury.
- For emergency use, install a fire extinguisher rated for energized electrical equipment fires (Class C rating or exact equivalent, with a non-conductive extinguishing agent) near the Distribution Center.

Installation Warnings

- The Distribution Center is designed to hold its pre-installed breaker box only. Do NOT attempt to install rack equipment inside the Distribution Center.
- The Distribution Center is extremely heavy. Use caution when handling the Distribution Center. Do not attempt to unpack, move or install it unassisted. Use a mechanical device such as a forklift or pallet jack to move the Distribution Center in the shipping container.
- Inspect the shipping container and the Distribution Center for shipping damage. If you determine that the Distribution Center has been damaged during shipping, or if anything appears to be missing, contact Tripp Lite for assistance. Do not use the Distribution Center if it is damaged.
- Leave the Distribution Center in the shipping container until it has been moved as close to the final installation location as possible. The casters are designed for minor position adjustments within the final installation area only. The casters are not designed for moving over longer distances.
- The casters are not designed to provide long-term support for the Distribution Center after final installation. Use the levelers to provide long-term support.
- Install the Distribution Center in a structurally sound area with a level floor that is able to bear the weight of the Distribution Center and any other equipment that will be installed nearby.
- Do not push the Distribution Center from the side panels to move it. Pushing from the side panels will cause a tipping hazard.
- When rolling the Distribution Center on its casters, always push it from behind, never pull it toward you.
- A rolling Distribution Center can cause personal injury and property damage if not properly supervised. If rolling the Distribution Center down a ramp is required, use extreme caution. Do not attempt to use ramps that have a slope steeper than 1:12.
- Do not tilt the Distribution Center or lay it on its side.
- Use caution when cutting packing materials. The Distribution Center could be scratched, causing damage not covered by the warranty.
- Save all packing materials for later use. Repacking and shipping the Distribution Center without the original packing materials may cause product damage not covered by the warranty.
- Do not attempt to unpack or move the Distribution Center without assistance. Use appropriate handling equipment rated to bear the weight and bulk of the Distribution Center, such as freight elevators, pallet jacks and forklifts. (Fully extend forks under load. Spread forks to maximum possible width under load. Lift cabinet from bottom only. Wear safety shoes.) Confirm that load limits for freight elevators, handling equipment and floors along the transport route will not be exceeded by the combined weight of the packaged Distribution Center, handling equipment and personnel. Confirm that the Distribution Center will pass through any doorways along the intended route.
- The Distribution Center is secured with stretch wrap to protect it during shipping and movement within a facility. Remove the stretch wrap from the Distribution Center when the Distribution Center is in the final installation location—not before.
- If the Distribution Center will be anchored to the floor, install appropriate anchor bolts in the mounting holes at the bottom of the cabinet. Use washers to create a level surface between the mounting areas around the anchor bolts.
- Use extreme caution when removing the bolts securing the Distribution Center to the shipping pallet.
- Use of this equipment in life support applications where failure of this equipment can reasonably be expected to cause the failure of the life support equipment or to significantly affect its safety or effectiveness is not recommended. Do not use this equipment in the presence of a flammable anesthetic mixture with air, oxygen or nitrous oxide.



DANGER! LETHAL HIGH VOLTAGE HAZARD!

All wiring must be performed by a qualified electrician, in accordance with the warnings in this manual and all applicable electrical and safety codes. Incorrect wiring may cause serious personal injury and property damage.

Wiring Warnings

- All wiring must be performed by a qualified, certified electrician. Know the procedure for disconnecting electricity in case of an emergency. Do not work alone. Use appropriate protective clothing and tools. Follow all applicable electrical wiring and safety regulations.
- The Distribution Center contains hazardous high voltages that have the potential to cause personal injury or death from electric shock.
- The Distribution Center must be suitably grounded according to all applicable electrical wiring regulations.
- De-energize all power sources before installing cables or making electrical connections.
- Use flexible cable of sufficient length to permit Distribution Center servicing.
- Confirm that all cables are marked correctly according to their purpose, polarity and diameter.

3 – Features

- A 42-Pole Circuit Breaker Panel:** Output branch circuit breakers (sold separately) snap into this panel. The output cord sets (sold separately) will be wired here. **Warning: Use Tripp Lite breakers and cord sets only.**
- B Main Circuit Breaker:** The 3-phase power source will be wired to this breaker.
- C Ground Bar:** Ground connections will be wired to this bar.
- D Neutral Bar:** Neutral connections will be wired to this bar.
- E Wiring Knockouts:** There are (24) 3/4-inch knockouts and (29) 1/2-inch knockouts distributed throughout the breaker box. (Not all knockouts are shown in the diagram. The top and bottom panels of the breaker box also contain knockouts.)
- F Removable Side Panel:** If the Distribution Center is installed on a concrete floor, the wiring from the 3-phase power source can be routed through the appropriate knockout in the removable side panel. You can install the side panel in the lower position on either side of the Distribution Center to accommodate the placement of the 3-phase power source.

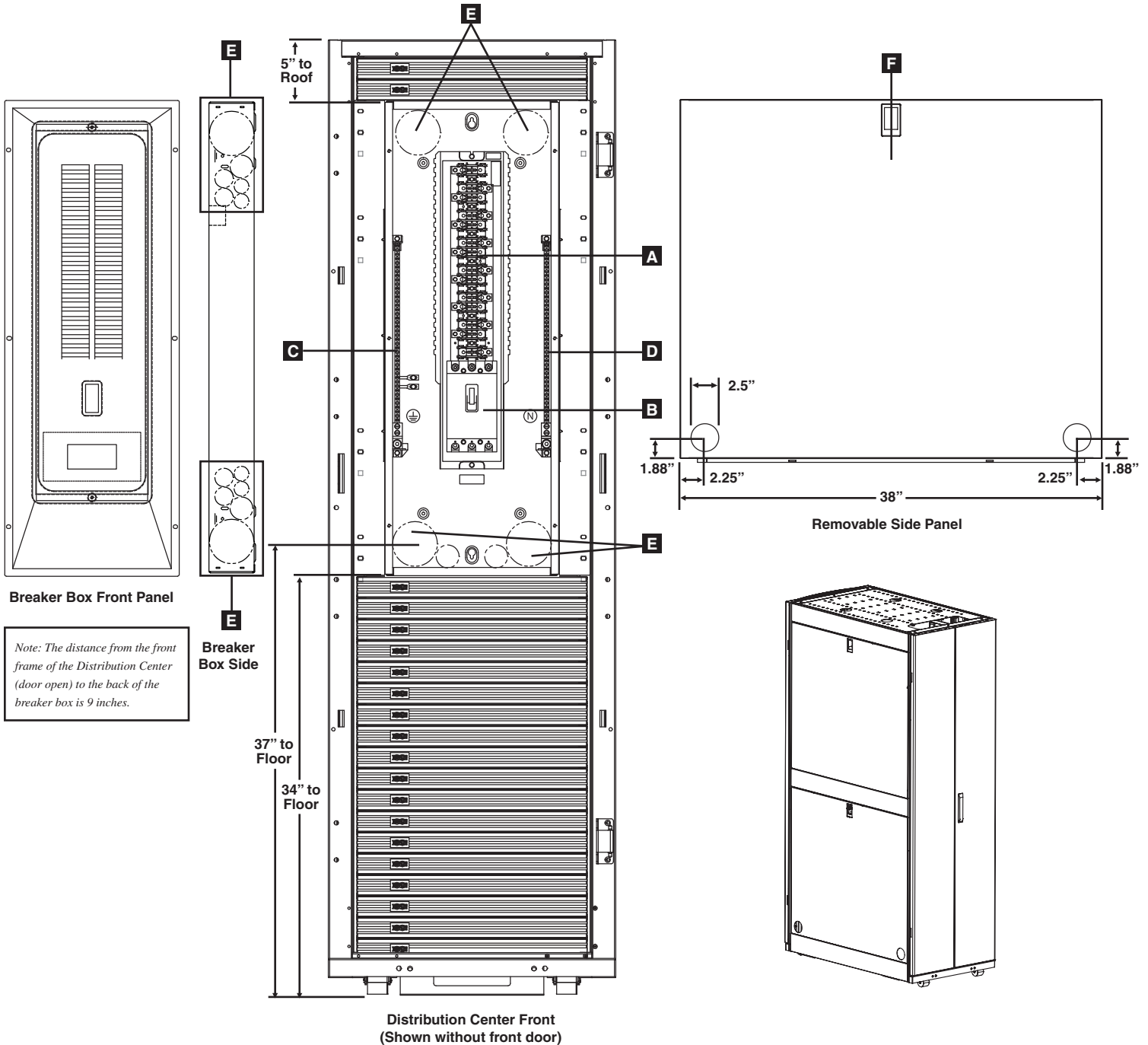

4 – Cabinet Installation



CAUTION! READ ALL INSTRUCTIONS AND WARNINGS BEFORE INSTALLATION!

WARNING: The Distribution Center is extremely heavy. Do not attempt to unpack, move or install the Distribution Center without assistance. Until it has been properly installed and stabilized, the Distribution Center is prone to tipping and could cause property damage and/or personal injury. Use extreme caution when handling the Distribution Center and be sure to follow all handling and installation instructions. Do not attempt to install wiring without first stabilizing the Distribution Center.

4.1 Preparation

The Distribution Center must be installed in a structurally sound area with a level floor that is able to bear the weight of the Distribution Center, all the wiring that will be installed in the Distribution Center and any enclosures and/or equipment that will be installed nearby. Before unpacking the Distribution Center, you should transport the shipping container closer to the final installation location to minimize the distance you will need to move the Distribution Center after the protective packaging has been removed. If you plan to store the Distribution Center for an extended period before installation, follow the instructions in the Storage & Service section.

You will need several tools (user-supplied):

- 13 mm Open-end Wrench
- 18 mm Open-end Wrench
- Utility Blade
- Carpenter's Level
- Phillips-head Screwdriver
- Flat-head Screwdriver

4.2 Unpacking

- 1** Confirm that the shipping container is upright and stable, then use a utility blade to cut the shrink-wrap securing the corner protectors. Apply the utility blade directly over the corner protectors to prevent the utility blade from scratching the Distribution Center or cutting the heavy protective plastic bag beneath the shrink-wrap. **WARNING: Do not scratch the Distribution Center or cut the heavy plastic bag beneath the shrink-wrap. Do not push or pull the Distribution Center while unpacking.**

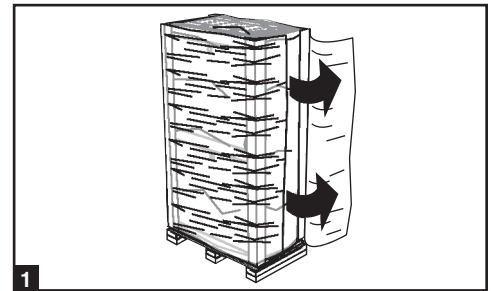

- 2** Remove the corner protectors. Save all packing materials (including the pallet) for later use unless you are certain they will not be required. The packing materials are recyclable.

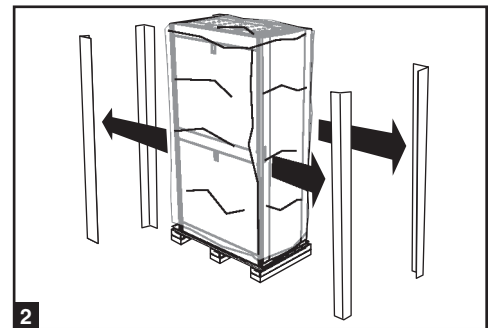

- 3** Remove the heavy plastic bag surrounding the Distribution Center. Examine the Distribution Center for any damage or loose parts. Confirm that all parts are present. If anything is missing or damaged, contact Tripp Lite for assistance. Do not attempt to use the Distribution Center if it has been damaged.

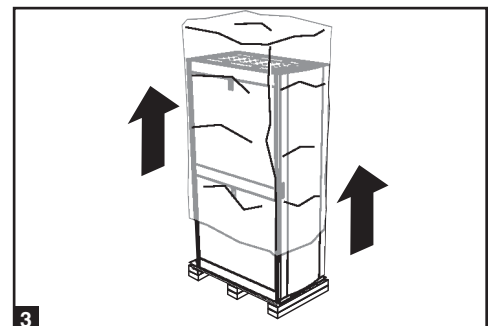

4 – Cabinet Installation continued

- 4 Use a 13 mm open-end wrench to remove the shipping brackets at the front and rear of the Distribution Center. Be extremely careful, as the Distribution Center could shift unexpectedly after bracket removal. Save the brackets and bracket hardware for later use. Position at least one person at the front of the Distribution Center and one person at the rear of the Distribution Center. Slowly push the Distribution Center toward the back of the shipping pallet until all four casters go over the edge of the pallet and touch the floor. **WARNING: Use at least one assistant when removing the Distribution Center from the pallet. Be extremely careful when moving the Distribution Center.**

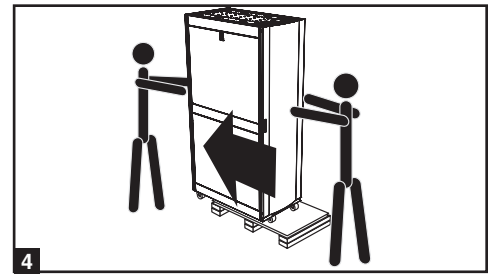

4.3 Placement

- 1 Use the casters to move the Distribution Center for a short distance over a level, smooth, stable surface by pushing it from the front or rear (not the side panels). Do not attempt to roll the Distribution Center over long distances. The Distribution Center should be moved close to its installation location inside its shipping container before it is unpacked. (Use a forklift or pallet jack to move the shipping container.) **WARNING: Do not push or pull the Distribution Center at the side panels or pull the enclosure toward you.**

If required, the Distribution Center can be lifted by attaching 4 user-supplied M8 diameter eye bolts to the threaded holes near the upper corners of the Distribution Center frame. Use steel bolts with an ISO strength rating of 8.8 or higher. **WARNING: Only experienced equipment operators should attempt to lift the Distribution Center. Use appropriate equipment and follow all applicable safety procedures and regulations.**

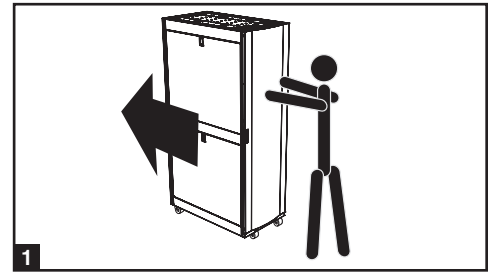

4.4 Leveling



WARNING!

Level the Distribution Center before attempting to install wiring. The casters are not designed to provide long-term support for the Distribution Center. Use the levelers to provide long-term support.

- 1 After the Distribution Center has been moved to the installation location, use a carpenter's level to check the slope of the floor. If the floor slopes more than 1%, choose an alternate installation site.

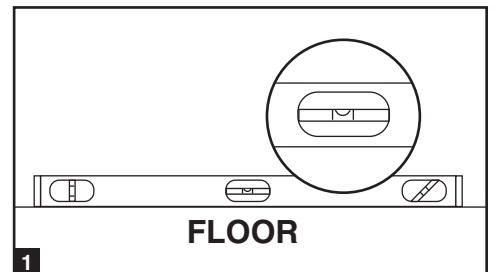

- 2 Use an 18 mm open-end wrench to lower each leveler **A** until it reaches the floor. (There are 4 levelers, 2 at the front and 2 at the rear.) Make sure each leveler contacts the floor solidly. *Note: Lower a leveler by turning it clockwise; raise a leveler by turning it counter-clockwise.*

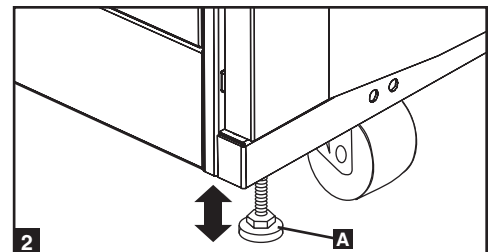

- 3 After lowering each leveler, use the carpenter's level to confirm that the Distribution Center is level in all directions. Adjust the levelers as required until the Distribution Center is level.

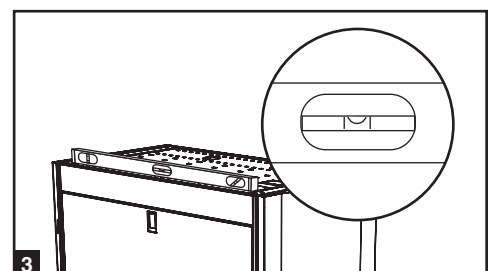

4 – Cabinet Installation continued

- 4** (Optional) If you wish to provide an additional measure of stability, you can attach the 2 shipping brackets, using the hardware that attached the Distribution Center to the shipping pallet. Use a 13 mm open-end wrench to connect the brackets to the outer **A** or inner **B** bracket mounting points of the Distribution Center. Attach the brackets to secure mounting points in the floor using user-supplied hardware or Tripp Lite's Bolt-Down Kit (Part # SRBOLTDOWN).

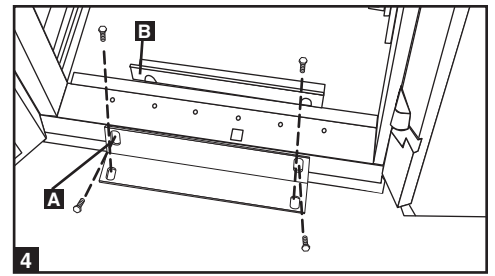

4.5 Ground Connection

All the parts of the Distribution Center are grounded to the frame of the enclosure. Use the Distribution Center's front or rear threaded grounding point **A** and an M6 screw (included) to connect the frame of the Distribution Center directly to your facility's earth ground connection with an 8 AWG wire. Route the ground wire under the Distribution Center's frame to ensure unhindered door operation. **WARNING: Attach the Distribution Center to earth ground separately—not daisy-chained with other equipment. Do not use the Distribution Center without an earth ground connection.**

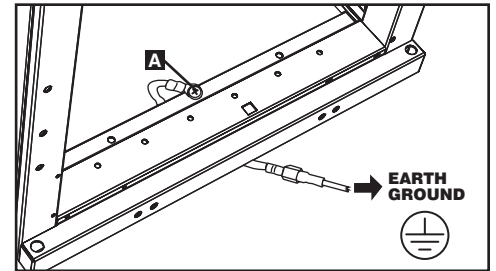

5 – Wiring Installation

5.1 Preparation

Warning: All wiring must be performed by a qualified, certified electrician.

- Review the entire manual before wiring the Distribution Center, including all warnings.
- Consider how you will route power into the unit, wire all internal connections and route power out of the unit, making careful measurements.
- Input wiring measurements will differ for concrete floor and raised floor installations. See Section 5.5 for more information.
- The cabling to wire the 3-phase power source to the Distribution Center is not included with the Distribution Center. Make sure the electrician supplies the appropriate cabling, in accordance with NEC and all other applicable local or national electrical regulations.
- Routing output cord sets from the top of the Distribution Center to your racks and PDUs should be managed systematically, with proper data and power cable segregation. Tripp Lite offers a full line of external cable management accessories (sold separately), including SRCABLELADDER, SRCABLETRAY and SRCABLETRAYEXP.

Ordering Required Breakers and Cord Sets

- Decide how many and what type of output breakers and cord sets you need (see below).
- Contact your distributor or go to www.tripplite.com to order.

Warning: Use Tripp Lite breakers and cord sets only.

Note: When ordering cord sets, order longer cords than the minimum required. The electrician can trim the ROJ section for a custom fit.

Available Output Branch Circuit Breakers

Tripp Lite #	Description
SUBB120	Single-Pole, 20A Breaker
SUBB230	2-Pole, 30A Breaker
SUBB320	3-Pole, 20A Breaker
SUBB330	3-Pole, 30A Breaker

5 – Installation continued

Available Cord Sets

120V, Single-Phase with L5-20R Connector. Use with compatible PDUs, including these Tripp Lite models: PDU1220T, PDU1420T, PDUNV, PDU40TDUAL, PDUMV20, PDUMV40, PDUMH20, PDUMNH20, PDUMNV20, PDUMV20NET, PDUMH20AT and PDUMH20ATNET.

Tripp Lite #	Total Length	ROJ Length	Wire	Connector	Compatible Breaker
SUWL520C-5	8 ft.	3 ft.	12 AWG Strand Wire	L5-20R	SUBB120
SUWL520C-10	13 ft.	3 ft.	12 AWG Strand Wire	L5-20R	SUBB120
SUWL520C-15	18 ft.	3 ft.	12 AWG Strand Wire	L5-20R	SUBB120
SUWL520C-20	23 ft.	3 ft.	12 AWG Strand Wire	L5-20R	SUBB120
SUWL520C-25	28 ft.	3 ft.	12 AWG Strand Wire	L5-20R	SUBB120
SUWL520C-30	33 ft.	3 ft.	12 AWG Strand Wire	L5-20R	SUBB120
SUWL520C-35	38 ft.	3 ft.	12 AWG Strand Wire	L5-20R	SUBB120
SUWL520C-40	43 ft.	3 ft.	12 AWG Strand Wire	L5-20R	SUBB120

Extensions

Tripp Lite #	Total Length	Wire	Connector & Plug	Compatible Breaker
SUWEL520C-3	3 ft.	12 AWG Strand Wire	L5-20R & L5-20P	SUBB120
SUWEL520C-20	20 ft.	12 AWG Strand Wire	L5-20R & L5-20P	SUBB120

208/240V, Single-Phase with L6-30R Connector. Use with compatible PDUs, including these Tripp Lite models: PDU1230, PDUV30HV, PDUMV30HV, PDUMNV30HV, PDUMV30NET, PDUMV30HVNET and PDUMH30HVNET.

Tripp Lite #	Total Length	ROJ Length	Wire	Connector	Compatible Breaker
SUWL630C-5	8 ft.	3 ft.	10 AWG Strand Wire	L6-30R	SUBB230
SUWL630C-10	13 ft.	3 ft.	10 AWG Strand Wire	L6-30R	SUBB230
SUWL630C-15	18 ft.	3 ft.	10 AWG Strand Wire	L6-30R	SUBB230
SUWL630C-20	23 ft.	3 ft.	10 AWG Strand Wire	L6-30R	SUBB230
SUWL630C-25	28 ft.	3 ft.	10 AWG Strand Wire	L6-30R	SUBB230
SUWL630C-30	33 ft.	3 ft.	10 AWG Strand Wire	L6-30R	SUBB230
SUWL630C-35	38 ft.	3 ft.	10 AWG Strand Wire	L6-30R	SUBB230
SUWL630C-40	44 ft.	3 ft.	10 AWG Strand Wire	L6-30R	SUBB230

Extensions

Tripp Lite #	Total Length	Wire	Connector & Plug	Compatible Breaker
SUWEL630C-3	3 ft.	10 AWG Strand Wire	L6-30R & L6-30P	SUBB230
SUWEL630C-20	20 ft.	10 AWG Strand Wire	L6-30R & L6-30P	SUBB230

208V, 3-Phase with L21-20R Connector.

Tripp Lite #	Total Length	ROJ Length	Wire	Connector	Compatible Breaker
SUWL2120C-5	8 ft.	3 ft.	12 AWG Strand Wire	L21-20R	SUBB320
SUWL2120C-10	13 ft.	3 ft.	12 AWG Strand Wire	L21-20R	SUBB320
SUWL2120C-15	18 ft.	3 ft.	12 AWG Strand Wire	L21-20R	SUBB320
SUWL2120C-20	23 ft.	3 ft.	12 AWG Strand Wire	L21-20R	SUBB320
SUWL2120C-25	28 ft.	3 ft.	12 AWG Strand Wire	L21-20R	SUBB320
SUWL2120C-30	33 ft.	3 ft.	12 AWG Strand Wire	L21-20R	SUBB320
SUWL2120C-35	38 ft.	3 ft.	12 AWG Strand Wire	L21-20R	SUBB320
SUWL2120C-40	43 ft.	3 ft.	12 AWG Strand Wire	L21-20R	SUBB320

Extensions

Tripp Lite #	Total Length	Wire	Connector & Plug	Compatible Breaker
SUWEL2120C-3	3 ft.	12 AWG Strand Wire	L21-20R & L21-20P	SUBB320
SUWEL2120C-20	20 ft.	12 AWG Strand Wire	L21-20R & L21-20P	SUBB320



WARNING!

Before wiring make sure that all breakers (including the Distribution Center's Main Breaker) are in the OFF position and that the 3-phase power source is de-energized!

5.2 Installing Breakers

- 1 Open the Distribution Center's front door to access the breaker box.
- 2 Remove 6 screws **A** from the breaker box front panel, then remove the panel and set it aside.
- 3 Decide which pole position to use for each of your required breakers and snap each breaker into place.
- 4 Remove the corresponding panel knockouts from the breaker box front panel.

Note: Properly label your breakers in the spaces provided to better manage your electrical system (labels not included). You may also want to differentiate labeling between different racks and cord sets.

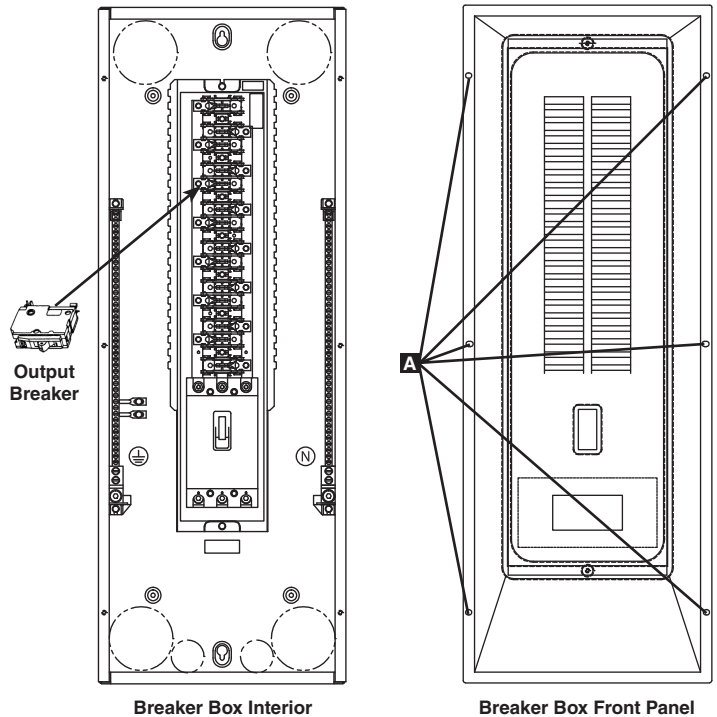

5.3 Installing Cord Sets

- 1 Pass the cord set through one of the cable access channels in the roof of the Distribution Center, ROJ section first. The channel you choose depends on your cord set configuration.
- 2 Select a knockout in the breaker box and remove the insert for that knockout. The knockout you choose depends on your cord set configuration. *Note: There are (24) 3/4-inch knockouts and (29) 1/2-inch knockouts distributed throughout the breaker box.*
- 3 Remove the coupling nut of the strain relief connector from the cord set.
- 4 Insert the ROJ section of the cord set through the knockout and into the breaker box. (Pull the ROJ section through the knockout until the threaded end of the strain relief connector is inside the breaker box.)
- 5 Insert the ROJ section of the cord set through the coupling nut of the strain relief connector.
- 6 Attach the coupling nut to the strain relief connector and tighten, securing the cord set to the breaker box.

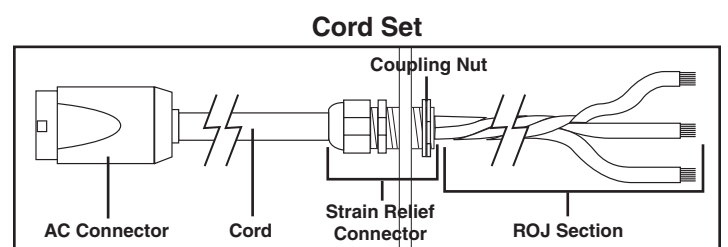
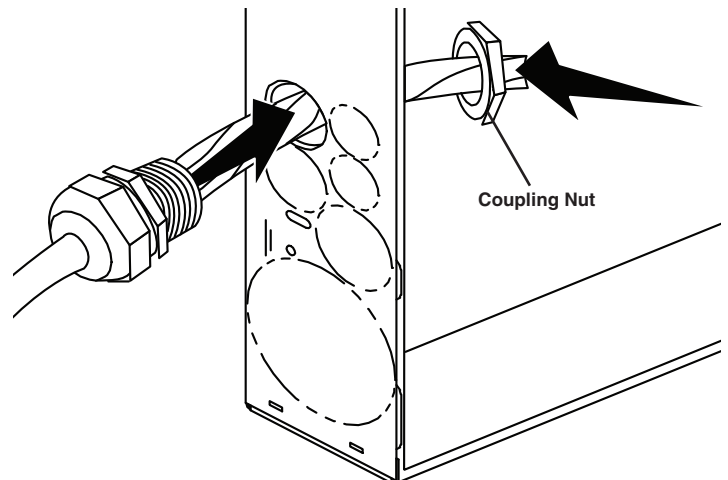

5 – Installation *continued*

- 7** After attaching your cord sets, route and attach these power cables to your equipment racks.
- Install the optional SRCABLELADDER, SRCABLETRAY and SRCABLETRAYEXP onto your racks for easier cable routing and management.
 - Starting with the cord sets for the racks farthest away from the Distribution Center, run each cable to your racks utilizing your configuration's cable management system.
 - Connect the appropriate cord set to the appropriate PDU, either inside your rack (through one of the cable access holes in the roof) or on top of your rack's roof inside the cable management tray.

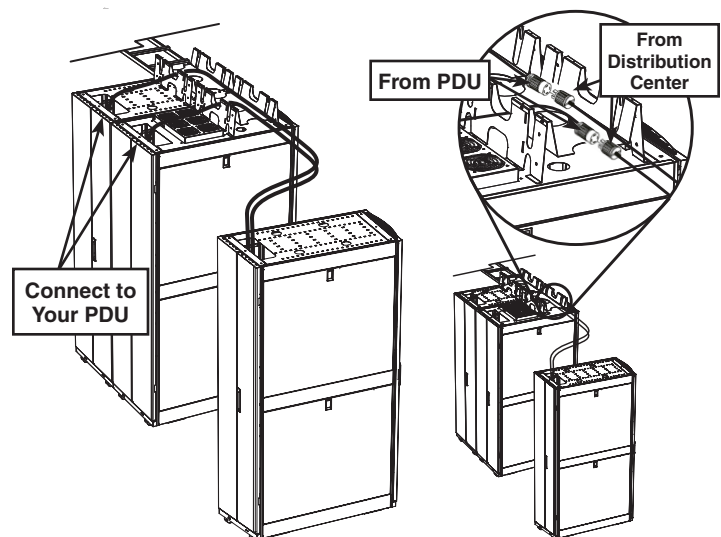

5.4 Wiring the Breakers



DANGER! LETHAL HIGH VOLTAGE HAZARD!

All wiring must be performed by a qualified, certified electrician in accordance with the warnings in this manual and all applicable electrical and safety codes. Incorrect wiring may cause serious personal injury and property damage.



Confirm that the main breaker is OFF before connecting any wiring.

- 1** Connect the ROJ section of each cord set to the appropriate breaker, neutral and ground, as appropriate. Leave circuit breakers in the OFF position until all wiring to load circuits is complete.
- 2** **Cord Sets Connected to 120V Circuits (L5-20R Connectors):**
- Connect green wire to the ground bar.
 - Connect white wire to the neutral bar.
 - Connect black wire to the 1-pole circuit breaker for that circuit (make sure the cord connector and 1-pole circuit breaker are labelled accordingly).
- 3** **Cord Sets Connected to 208V Circuits (L6-30R Connectors):**
- Connect green wire to the ground bar.
 - Connect black wire to 1 pole of the 2-pole circuit breaker for that circuit.
 - Connect white wire to the 2nd pole of the 2-pole circuit breaker for that circuit.

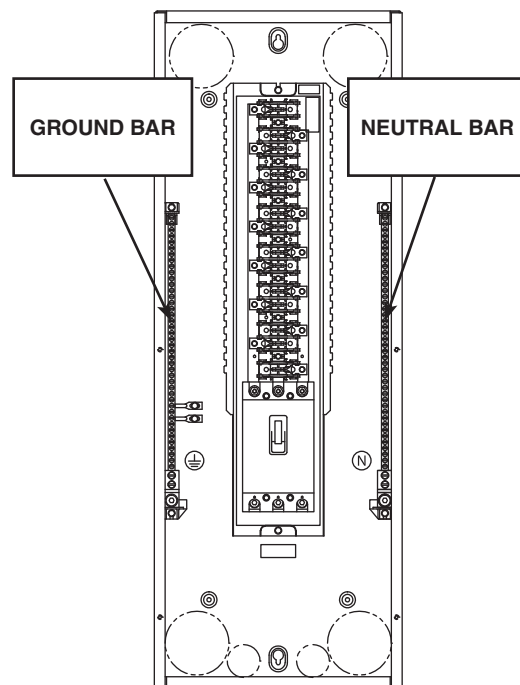

5.5 Wiring Input Power

Warning: Before wiring the 3-phase UPS to the Distribution Center’s main breaker, turn the UPS OFF and de-energize it completely.

The main breaker accepts wiring up to 300 MCM. Recommended minimum wiring sizes are shown below, but the electrician must make the final wiring determination for your configuration in compliance with NEC and all other applicable electrical and safety regulations. The electrician may wish to refer to Tripp Lite’s *3-Phase Domestic Site Planning Data Sheet*, downloadable at www.tripplite.com.

Input power to the Distribution Center’s main input must be 3-phase, 4 wire + ground from a 120/208V 3-phase source. The use of ferrules on stranded wire is recommended.

3-Phase UPS Capacity	Recommended Minimum Wire Size*
20kVA	6 AWG
30kVA	3 AWG
40kVA	1 AWG
60kVA	000 AWG
>60kVA	Not Supported - Do Not Connect

*Conductors Rated 90°C

Raised Floor

- Run the wiring from the 3-phase power source, under the raised floor and up through the open base of the Distribution Center.
- Use the center-bottom conduit knockout of the breaker box below the main circuit breaker to attach the input flexible conduit.
- Wire the 3-phase power source to the bottom of the main input breaker, neutral and ground.

Concrete Floor

- Run the wiring from the 3-phase power source through the bottom side panel of the Distribution Center. The side panel has two knockouts to accommodate the wiring—choose the most convenient knockout. *Note: You can install the side panel in the lower position on either side of the Distribution Center to accommodate the placement of the 3-phase power source.*
- Use the center-bottom conduit knockout of the breaker box below the main circuit breaker to attach the input flexible conduit.
- Wire the 3-phase power source to the bottom of the main input breaker, neutral and ground.

Note: To maintain same-phase rotation within the panel board as output from the AC source, connect the R, S and T phases (also known as A, B and C phases) to the main circuit breaker lugs from left to right.

5.6 Powering Up

- Turn the AC source (UPS system) ON, following all normal start-up procedures for the AC source.
- Turn the Distribution Center’s MAIN breaker ON. **Warning! After you turn the main breaker ON, the breaker box will be energized.**
- Verify that voltages from phase-phase are 208V (NOM), phase-neutral are 120V (NOM) and neutral-ground is 0V.
- Reattach the breaker box front panel.
- Close the Distribution Center’s front door.
- Plug PDUs into the cord sets as required to power your equipment.
- Turn the output branch circuit breakers ON. **Warning! After you turn the output branch circuit breakers ON, the cord sets and anything plugged into the cord sets will be energized.**

5.7 Powering Down

- To power down the entire Distribution Center, turn OFF the main breaker. **Warning! The UPS system wiring will remain energized until you turn the UPS system OFF.**
- To power down an output branch circuit, turn OFF the corresponding output branch circuit breaker. **Warning! The breaker box will remain energized until you turn the main breaker OFF.**

6 – Storage & Service

Storage

The Distribution Center must be stored in a clean, secure environment with a temperature less than 40° C (104° F) and a relative humidity less than 95% (non-condensing). Store the Distribution Center in its original shipping container if possible.

Service

Your Tripp Lite product is covered by the warranty described in this manual. A variety of Extended Warranty and On-Site Service Programs are also available from Tripp Lite. For more information on service, visit www.tripplite.com/support. Before returning your product for service, follow these steps:

1. Review the installation and operation procedures in this manual to insure that the service problem does not originate from a misreading of the instructions.
2. If the problem continues, do not contact or return the product to the dealer. Instead, visit www.tripplite.com/support.
3. If the problem requires service, visit www.tripplite.com/support and click the Product Returns link. From here you can request a Returned Material Authorization (RMA) number, which is required for service. This simple on-line form will ask for your unit's model and serial numbers, along with other general purchaser information. The RMA number, along with shipping instructions will be e-mailed to you. Any damages (direct, indirect, special or consequential) to the product incurred during shipment to Tripp Lite or an authorized Tripp Lite service center is not covered under warranty. Products shipped to Tripp Lite or an authorized Tripp Lite service center must have transportation charges prepaid. Mark the RMA number on the outside of the package. If the product is within its warranty period, enclose a copy of your sales receipt. Return the product for service using an insured carrier to the address given to you when you request the RMA.

7 – Warranty & Warranty Registration

Limited Warranty

Seller warrants this product, if used in accordance with all applicable instructions, to be free from original defects in material and workmanship for a period of 1 year from the date of initial purchase. If the product should prove defective in material or workmanship within that period, Seller will repair or replace the product, in its sole discretion. Service under this Warranty includes parts and Tripp Lite service center labor. On-site service plans are available from Tripp Lite through authorized service partners (in most areas). Visit www.tripplite.com/support for details. International customers should contact Tripp Lite support at intlservice@tripplite.com.

THIS WARRANTY DOES NOT APPLY TO NORMAL WEAR OR TO DAMAGE RESULTING FROM ACCIDENT, MISUSE, ABUSE OR NEGLIGENCE. SELLER MAKES NO EXPRESS WARRANTIES OTHER THAN THE WARRANTY EXPRESSLY SET FORTH HEREIN. EXCEPT TO THE EXTENT PROHIBITED BY APPLICABLE LAW, ALL IMPLIED WARRANTIES,

INCLUDING ALL WARRANTIES OF MERCHANTABILITY OR FITNESS, ARE LIMITED IN DURATION TO THE WARRANTY PERIOD SET FORTH ABOVE; AND THIS WARRANTY EXPRESSLY EXCLUDES ALL INCIDENTAL AND CONSEQUENTIAL DAMAGES. (Some states do not allow limitations on how long an implied warranty lasts, and some states do not allow the exclusion or limitation of incidental or consequential damages, so the above limitations or exclusions may not apply to you. This Warranty gives you specific legal rights, and you may have other rights which vary from jurisdiction to jurisdiction.)

Tripp Lite; 1111 W. 35th Street; Chicago IL 60609; USA

WARNING: The individual user should take care to determine prior to use whether this device is suitable, adequate or safe for the use intended. Since individual applications are subject to great variation, the manufacturer makes no representation or warranty as to the suitability or fitness of these devices for any specific application.

WARRANTY REGISTRATION

Visit www.tripplite.com/warranty today to register the warranty for your new Tripp Lite product. You'll be automatically entered into a drawing for a chance to win a FREE Tripp Lite product!*

* No purchase necessary. Void where prohibited. Some restrictions apply. See website for details.

Tripp Lite has a policy of continuous improvement. Specifications are subject to change without notice.



1111 W. 35th Street, Chicago, IL 60609 USA
www.tripplite.com/support