

Quick Start Guide

ELITE Remote



www.eliteprompter.com

Quick Start Guide

Thank you for purchasing ELITE Remote – Bluetooth iPad teleprompter remote. Please follow these simple instructions to get started.

Downloading ELITE Prompter – Professional iPad Teleprompter App

1. Go to the App Store on your iPad



2. Locate the search bar at the top right corner and key in "ELITE Prompter"
3. Select the app and install it



Paid Version

or



Free Version

Inserting battery into ELITE Remote

1. Remove the battery tray at the back of the remote
2. Insert 2 AAA batteries into the battery bay
3. Close the battery bay

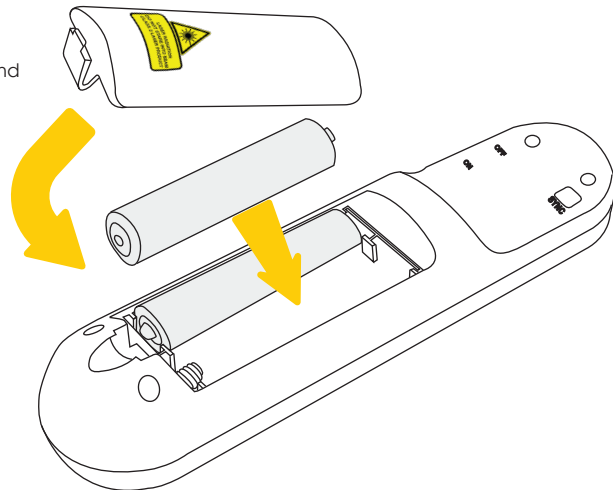

Troubleshooting

If you have any issues with ELITE Remote or ELITE Prompter App, please call us at 1.713.272.8822 Monday through Friday 9:00am to 6:00pm CST. Or you can email us at software@ikancorp.com.

ikan

Syncing ELITE Remote to your iPad

1. Go to the "Settings" app on your iPad 
2. Select the "General" tab on the left side, then select "Bluetooth" tab on the right side
3. Turn on Bluetooth if it's not already on. DO NOT close this screen on your iPad

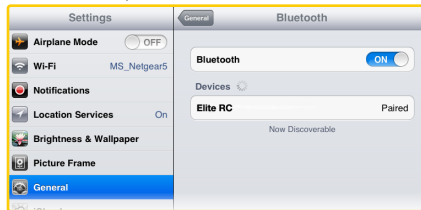

4. Turn on the remote with the ON/OFF Switch located at left side of the remote. A red light should blink momentarily on the front side of the remote
5. Press the sync button at the back of the remote. A blue light should blink momentarily on the front side of the remote
6. The words "Elite RC" should appear on your iPad. Select it.
7. Once connection between the iPad and the remote has been established, the status message next to "Elite RC" should change to "Paired"

Re-establishing connection with your iPad

Once you sync your iPad and ELITE remote, your iPad will always remember ELITE Remote. To re-establish connection, simply turn on the remote, press any button, and wait a few seconds. The remote will automatically re-establish connection with your iPad.

Controlling your iPad with ELITE Remote

