

**MOVING APPLICATIONS: Avoid strain from motion on the fiber connection**

- 1) **BEST OPTION:** To avoid strain and motion on fiber connector, use coax cable to connect to the media converter in the:  
(A) Equipment Room or  
(B) Field VMCP-4 Quad box.

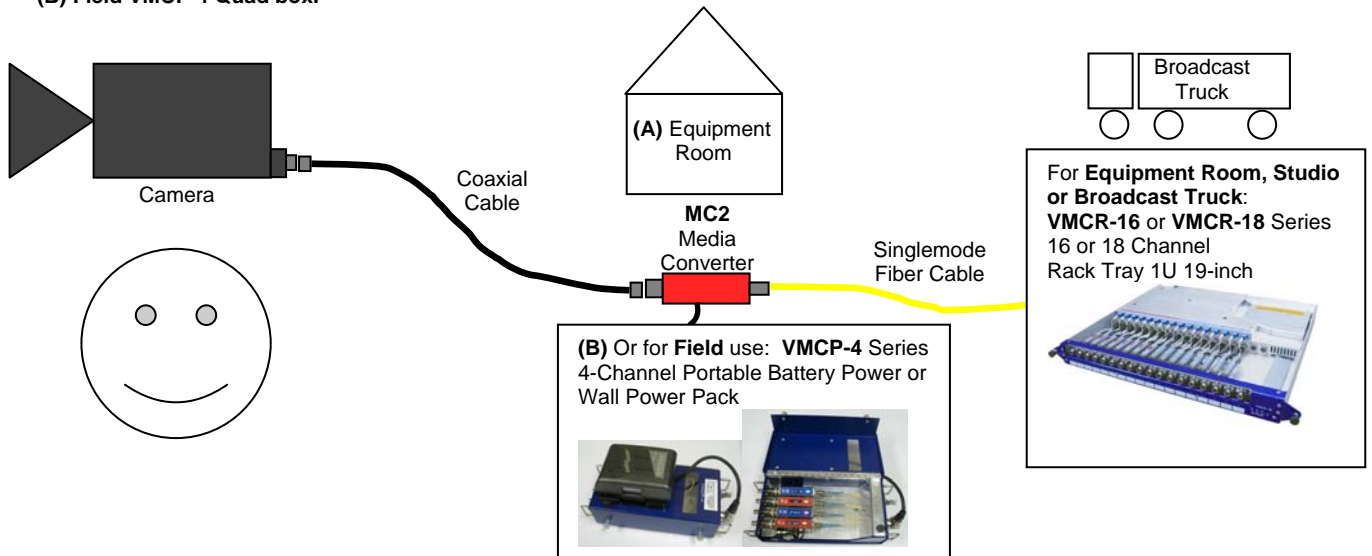

- 2) If must mount to a camera, **USE FIBER LOOP** to avoid strain and motion on fiber connector. Use proper strain relief and attach the fiber loop to a fixed object that moves with the camera.

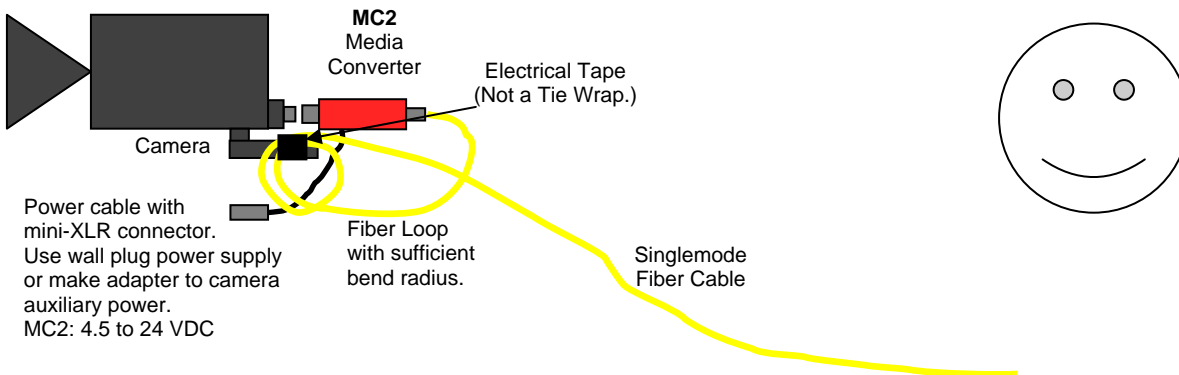

- 3) **DO NOT USE.** Avoid strain and motion on fiber connector.

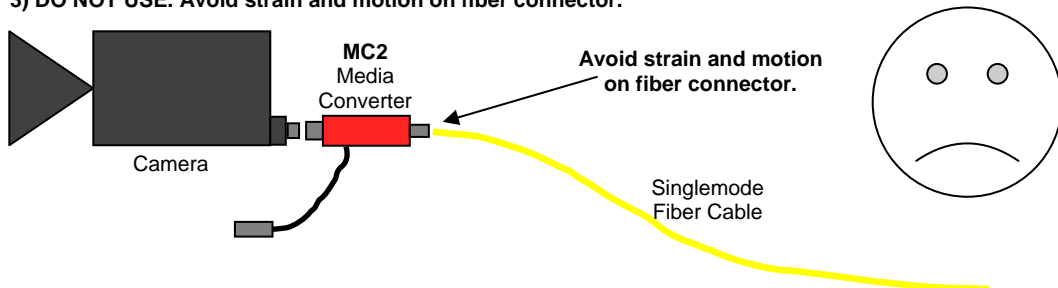

**NOTE:** Always use good fiber cable management, follow fiber bend radius recommendations and use appropriate strain relief techniques.