

ASP-HTV

HDMI/DVI to VGA Converter

User Manual



Manual Number: 100902

Full HD
1080
WUXGA
1920
x
1200

HDMI[™]
HIGH-DEFINITION MULTIMEDIA INTERFACE

dvi
digital
visual interface



Aurora
Multimedia



Safety and Notice

The ASP-HTV has been tested for conformity to safety regulations and requirements, and has been certified for international use. However, like all electronic equipments, the ASP-HTV should be used with care. Please read and follow the safety instructions to protect yourself from possible injury and to minimize the risk of damage to the unit.

- Follow all instructions and warnings marked on this unit.
- Do not attempt to service this unit yourself, except where explained in this manual.
- Provide proper ventilation and air circulation and do not use near water.
- Keep objects that might damage the device and assure that the placement of this unit is on a stable surface.
- Use only the power adapter and power cords and connection cables designed for this unit.
- Do not use liquid or aerosol cleaners to clean this unit. Always unplug the power to the device before cleaning.



Warning!

***This device is served purely for conversion between video formats.
This device CANNOT convert the input/output video resolutions.***

This ASP-HTV HDMI/DVI to VGA/Component & Audio Converter offers an easy and instant approach for converting digital HDMI to analog PC video (VGA) and component video (YPbPr) with digital audio (S/PDIF) and analog stereo audio. With this module, YPbPr/VGA based receivers such as LCD monitors or plasma TV can be readily connected to HDMI sources such as DVD players or PS3. In addition, the embedded HDMI / DVI selector facilitates the switch between the HDMI and DVI input sources. This cost effective solution let you keep using your non-HDMI/DVI display to access HDMI or DVI source, and enjoy high definition digital video and audio.

Features

- HDMI 1.2a & DVI 1.1 compliant
- HDMI video supports up to 1080p
- Support HD (1080i / 720p) component video output
- Support up to UXGA (1600x1200@60) & WUXGA (1920x1200@60) PC graphics output
- Coaxial S/PDIF audio output
- Stereo analog audio output
- Front panel LED indicators and push button
- EDID learning ability

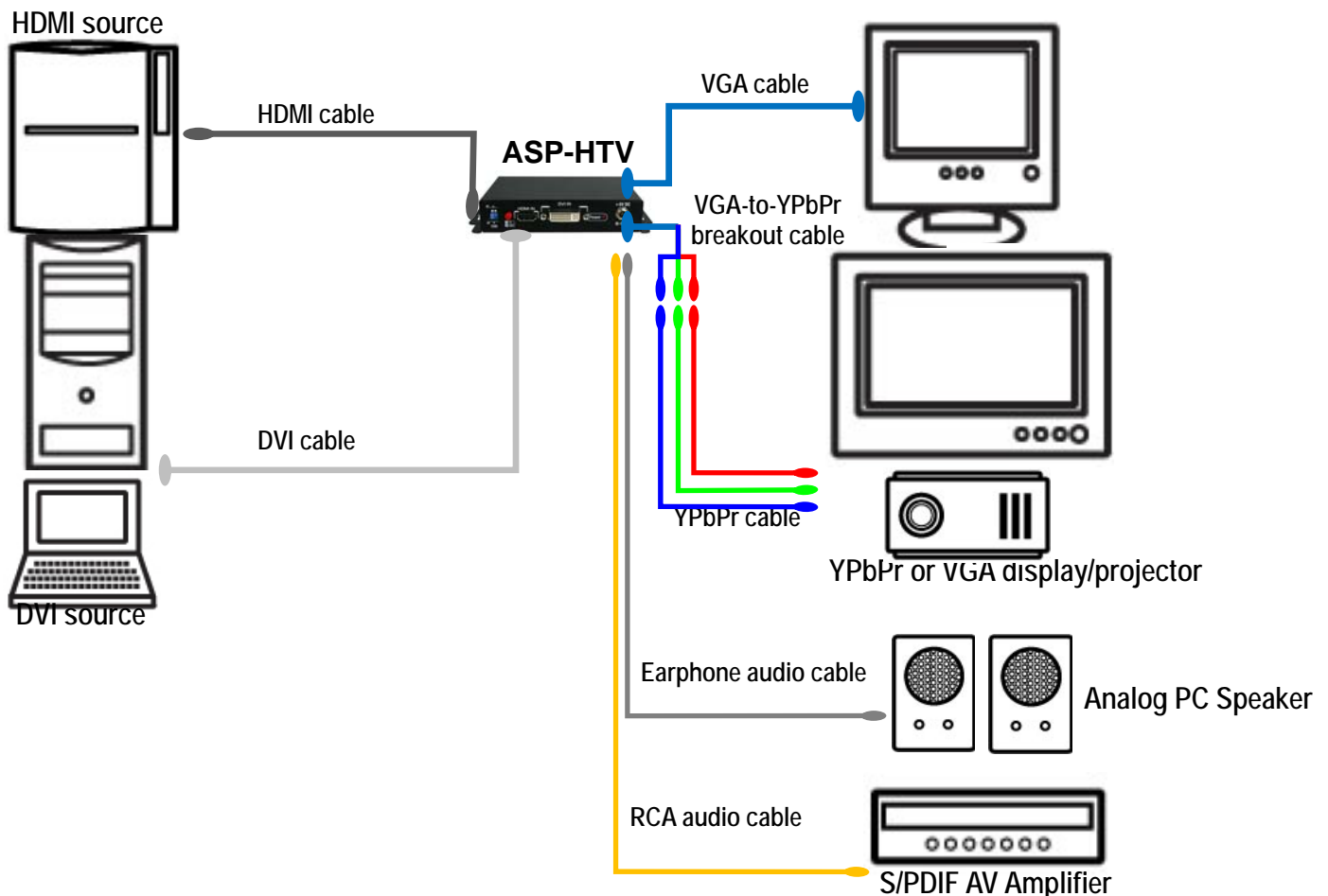

Specifications & Package Contents

Model Name		ASP-HTV
Technical		
Role of usage		D/A converter
HDMI compliance		HDMI 1.2a
DVI compliance		DVI 1.1
Video bandwidth		Single-link 165MHz [4.95Gbps]
Video support		Up to 1080p60, WUXGA [1920x1200@60] & UXGA [1600x1200@60]
Audio support		Stereo audio
Input TMDS signal		1.2 Volts [peak-to-peak]
Input DDC signal		5 Volts [peak-to-peak, TTL]
Input		1x HDMI 1x DVI
Output		1x VGA/Component (through VGA-component breakout cable) 1x RCA digital audio 1x 3.5mm analog audio
HDMI connector		Type A [19-pin female]
DVI connector		DVI-I [29-pin female digital only]
VGA connector		HD-15 [15-pin D-sub female]
RCA connector		Coaxial socket for S/PDIF digital stereo audio [PCM 48kHz]
3.5mm connector		Earphone socket for analog stereo audio
Push-in button		[1] HDMI/DVI input switch / [2] VGA/component output switch
DIP switch		2-pin for EDID learning
Mechanical		
Housing		Metal enclosure
Dimensions [L x W x H]	Model	128 x 100 x 28mm [5.0"x3.9"x1.1"]
	Package	270 x 175 x 80mm [10.6"x6.9"x3.1"]
	Carton	450 x 370 x 300mm [1'6"x1'3"x1']
Weight	Model	420g [15oz]
	Package	795g [1.8 lbs]
Fixedness		Wall-mounting case with screws
Power supply		5V 2A DC
Power consumption		6 Watts [max]
Operation temperature		0~40°C [32~104°F]
Storage temperature		-20~60°C [-4~140°F]
Relative humidity		20~90% RH [no condensation]
Package Contents		1x HTV 1x VGA-component breakout cable 1x 5V power adapter 1x User Manual

Resolution Support

PC Graphics [DVI or VGA]

VESA 640x400 @85Hz	VESA 1024x768 @60Hz	VESA 1280x960 @85Hz	1152x864@60Hz
VESA 720x400 @85Hz	VESA 1024x768 @75Hz	VESA 1280x1024 @60Hz	Mac 480-66A
VESA 640x480 @72Hz	VESA 1024x768 @85Hz	VESA 1280x1024 @85Hz	Mac 480-66B
VESA 640x480 @75Hz	VESA 1152x864 @60Hz	VESA 1360x768 @60Hz	Mac 600-66
VESA 640x480 @85Hz	VESA 1152x864 @75Hz	VESA 1440x900 @60Hz	Mac 768-60
VESA 800x600 @60Hz	VESA 1280x768 @60Hz	VESA 1400x1050 @60Hz	Mac 870-75
VESA 800x600 @72Hz	VESA 1280x768 @75Hz	VESA 1400x1050 @75Hz	IBM 6000
VESA 800x600 @75Hz	VESA 1280x768 @85Hz	VESA 1920x1200 @60Hz	NEC 1024-70
VESA 800x600 @85Hz	VESA 1280x960 @60Hz	VESA 1600x1200 @60Hz	SUN 1024-76

Video [HDMI or component (YPbPr)]

EIA 720x480p @59.94(60)Hz
EIA 720x576p @50Hz
EIA 1280x720p @59.94(60)Hz
EIA 1920x1080i @59.94(60)Hz
EIA 1920x1080p @59.94(60)Hz
712x484 (NTSC)
702x574 (PAL)

Front Panel

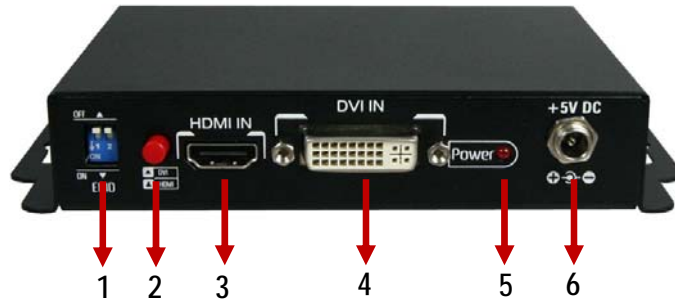

- 1. DIP Switch for EDID
- 2. HDMI or DVI source switch button
- 3. HDMI input
- 4. DVI input
- 5. Power on/off indicator
- 6. +5V DC interlocked power jack

EDID DIP Switch

1	Mode
On ↓	Learn EDID from VGA socket and save EDID to HDMI socket
Off ↑	Write back the default EDID to HDMI socket
2	
On ↓	Learn EDID from VGA socket and save EDID to DVI socket
Off ↑	Write back the default EDID to DVI socket

Rear Panel



- 7. S/PDIF audio output
- 8. Stereo audio output
- 9. VGA output or component output via connecting a breakout cable
- 10. VGA or component output switch button

Hardware Installation

1. Connect HDMI or DVI source to the video input.
2. Connect S/PDIF or stereo audio source to RCA jack or 3.5mm jack.
3. For connecting to VGA display/projector, link VGA cable to the VGA output connector. For connecting to component (YPbPr) video display/projector, link VGA-component breakout cable first to the VGA output connector then link a component cable to the component (YPbPr) display/projector.
4. Power up the ASP-HTV.

EDID Learning

1. Power up the ASP-HTV. Connect display to **VGA/YPbPr Output**.
2. To learn EDID for HDMI source, please power up ASP-HTV first. Secondly pull down the **DIP switch 1 to ON**, and the red light will be dark and bright to indicate the EDID learning process is complete. Finally, please remember to reboot ASP-HTV for updating. You **DON'T NEED** to pull up the DIP switch again unless you want to learn another EDID by pulling DIP switch 1 up and down.
3. To learn EDID for DVI source, please power up ASP-HTV first. Secondly pull down the **DIP switch 2 to ON**, and the red light will be dark and bright to indicate the EDID learning process is complete. Finally, please remember to reboot ASP-HTV for updating. You **DON'T NEED** to pull up the DIP switch again unless you want to learn another EDID by pulling DIP switch 2 up and down.

Notice

1. Only HDMI enabled TV sets with **underscan/overscan*** support, the full active video can be accurately displayed. Some HDMI equipped TV sets may not support this feature. If **underscan/overscan*** is NOT supported, the top, bottom, left and right border of the active video may be screened, and the S/PDIF audio may not sound right.
2. Analog stereo audio can merely support 2-channel audio. This version does NOT support 8-channel analog audio applications.
3. S/PDIF audio input supports the main 2-channel audio input
4. S/PDIF supports only 48kHz audio sample rate. Other than this rate, the input digital audio should be adjusted to 48kHz in order to get audio signal correctly sent.

The **underscan mode displays the full video frame, which reveals content on the edge that is recorded. In **overscan**, the field monitor zooms in to the area that would be visible on most televisions. Set the field monitor to underscan if your video will be viewed on a computer monitor or shown with a projector and also to look for light stands, microphones, and other unwanted objects on the edges of your shot. Set it to overscan to see how the video will look on a television.*

Limited 3 Year Warranty

Aurora Multimedia Corp. ("Manufacturer") warrants that this product is free of defects in both materials and workmanship for a period of 3 years as defined herein for parts and labor from date of purchase. Motorized mechanical parts (Hard Drives, DVD, etc), mechanical parts (buttons, doors, etc), remotes and cables are covered for a period of 1 year. Batteries are not covered by this warranty. During the warranty period, and upon proof of purchase, the product will be repaired or replaced (with same or similar model) at our option without charge for parts or labor for the specified product warranty period.

This warranty shall not apply if any of the following:

- A) The product has been damaged by negligence, accident, lightning, water, act-of-God or mishandling; or,
- B) The product has not been operated in accordance with procedures specified in operating instructions; or,
- C) The product has been repaired and or altered by other than manufacturer or authorized service center; or,
- D) The product's original serial number has been modified or removed; or,
- E) External equipment other than supplied by manufacturer, in determination of manufacturer, shall have affected the performance, safety or reliability of the product.
- F) Part(s) are no longer available for product.

In the event that the product needs repair or replacement during the specified warranty period, product should be shipped back to Manufacturer at Purchaser's expense. Repaired or replaced product shall be returned to Purchaser by standard shipping methods at Manufacturer's discretion. Express shipping will be at the expense of the Purchaser. If Purchaser resides outside the contiguous US, return shipping shall be at Purchaser's expense.

No other warranty, express or implied other than Manufacturer's shall apply.

Manufacturer does not assume any responsibility for consequential damages, expenses or loss of revenue or property, inconvenience or interruption in operation experienced by the customer due to a malfunction of the purchased equipment. No warranty service performed on any product shall extend the applicable warranty period.

This warranty does not cover damage to the equipment during shipping and Manufacturer assumes no responsibility for such damage.

This product warranty extends to the original purchaser only and will be null and void upon any assignment or transfer.

Aurora Multimedia Corp.
205 Commercial Court, Morganville, NJ 07751
Phone: (732) 591-5800 Fax: (732) 591-5801
www.auroramultimedia.com