



HB-702

The HB-702 is a two-channel-selectable, full-duplex headset station, able to be mounted into a wall or other surface. The HB-704 is identical, but can access four channels of intercom. These headset stations are ideal for installation in theatrical, performance, broadcast, and industrial facilities - wherever a multi-channel, full-duplex headset communications panel is desired.

Both units mount in a standard U.S. two-gang outlet box. The stations offer excellent speech intelligibility even in high noise environments. Microprocessor-controlled logic plus a set of internal and external controls allow the features of these stations to be tailored to the needs of the user. Electronic switching for the talk button, blue-color LED (on) or amber-color (off), permits momentary or latching operation. A Remote Mic Kill (RMK) signal on the intercom line will turn off the talk function if it is accidentally left on.

A red-color LED tracks the incoming call signal, so it can be used for visual cueing. An associated call button allows the user to place a call signal on the selected intercom line. The standard 4-pin XLR headset jack accommodates Clear-Com and compatible dynamic headsets. A sidetone level control adjusts the amount of the user's voice heard in the headset. An automatic limiter circuit adjusts and limits the microphone output to the intercom line. A two-position switch on the HB-702, and a four-position switch on the HB-704, allow the user to select from the attached intercom channels. Connections to the intercom lines are made via a screw-terminal block, using standard two-wire shielded mic cable.



HB-704

Either of the stations may be used with the optional TW (two channels on a single mic cable) daughter board. With the TW board, the stations become plug-in compatible with a Clear-Com TW system. The HB-702 may be used with the optional 4-wire board, which creates separate send and receive circuits so that the station may be attached to fiber-optic lines or other audio routing systems with 4-wire connections. The HB-702 and HB-704 are housed in a durable package with a steel front panel.

Features:

- Selectable two- or four-channel, full-duplex communication
- Microprocessor controlled logic and switching
- Momentary/latching talk switch with LED
- Visual call signaling with bright LED indicator
- Headset connector with volume control and sidetone adjust
- Use with optional TW or 4-wire circuit boards
- Easy installation and connection

Technical Specifications:

dBu is an absolute measurement. 0 dBu is referenced to 0.775 volts RMS

Headset Microphone Input

Input Type : Dynamic
 Input Impedance: $\geq 1\text{K}\Omega$
 Mic Limiter Threshold: $-2\text{dBu} \pm 3\text{dB}$
 Mic Limiter Range: $\geq 15\text{dB}$

Program Line Input

Input Impedance: $\geq 5\text{K}\Omega$

Headset Output

Load Impedance: $\geq 8\Omega$
 Output Impedance: $\leq 25\Omega$
 Output Limiter Threshold: $+5\text{dBu} \pm 3\text{dB}$
 Maximum Output Level before Distortion: $\geq 17\text{dBu}$

Party Line Output

Off Noise: $< -74\text{dBu}$
 Output Impedance: $> 10\text{K}\Omega$

Party Line Input

Crosstalk: $< -60\text{dB}$
 Max level before Clipping: $\geq 12\text{dBu}$

Frequency Response

Headset Mic - Party Line: $300 - 15\text{KHz} \pm 3\text{dB}$
 Party Line - Headset Out: $300 - 15\text{KHz} \pm 3\text{dB}$

Max Distortion

Headset Mic - Party Line: $\leq 0.5\%$
 Party Line - Headset Out: $\leq 0.2\%$

Noise

Headset Mic - Party Line: $< -70\text{dBu}$

Max Gain

Headset Mic - Party Line: $41\text{dB} \pm 2\text{dB}$
 Party Line - Headset Out: $\geq 34\text{dB}$

Power

Input Voltage Range: $20-30\text{VDC}$
 Input Current (Idle): $\leq 50\text{mA}$
 Input Current (Max): $\leq 100\text{mA}$

Internal Adjustments and Connections

Intercom Line (HB-702/HB-704): Seven terminal connector
 Two DIP switches
 Option Switches: Two sets of options
 Option Board Jumper: Two sets of options jumpers

Front Panel Connectors

Headset: (1) XLR-4M

Front Panel Controls & Indicators

- (1) Sidetone control
- (1) Talk button
- (1) Call button
- (1) Channel select switch
- (1) Volume control

Environmental

$32 - 122^\circ\text{F} (0 - 50^\circ\text{C})$

Dimensions (HB-702/HB-704)

4.625 in. W x 4.5 in. H x 1.75 in. D
 (117 mm x 114 mm x 44 mm)

Weight

0.46 lbs. (0.21 Kg)

Notice About Specifications

While Clear-Com makes every attempt to maintain the accuracy of the information contained in its product manuals, that information is subject to change without notice. Performance specifications included in this manual are design-center specifications and are included for customer guidance and to facilitate system installation. Actual operating performance may vary.

Dimensional Drawings

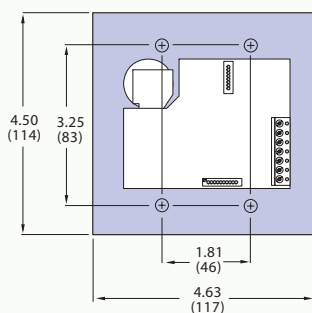

HB-702 FRONT VIEW

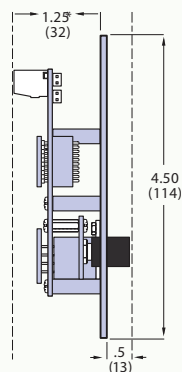

HB-702 SIDE VIEW

* 1.75" with option modules