

# V2-28

TWO-WAY, FULL-RANGE  
COMPACT LOUDSPEAKER SYSTEM,  
FREQUENCY SHADED LF



## SPECIFICATIONS

<b>Loudspeaker Type:</b>	Compact two-way, full-range, trapezoidal, vented bass, frequency shaded LF, user rotatable horn
<b>Operating Range:</b>	60 Hz to 18 kHz (-10 dB)
<b>Frequency Response:</b>	90 Hz to 16 kHz ( $\pm 3$ dB)
<b>Max Input Ratings:</b>	300W continuous, 750W program 34.6 volts RMS, 69.2 volts momentary peak
<b>Sensitivity (1W/1m):</b>	94 dB (100 Hz to 12.5 kHz) free space
<b>Maximum Output:</b>	119 dB SPL / 125 dB SPL (peak)
<b>Nominal Impedance:</b>	4 ohms
<b>Minimum Impedance:</b>	3.4 ohms @ 200 Hz
<b>Nominal -6dB Beamwidth:</b>	90° H x 70° V (in vertical position)
<b>Crossover Frequency:</b>	1.3 kHz
<b>Recommended Signal Processing:</b>	70 Hz, 24 dB/octave Butterworth high pass filter
<b>Drivers:</b>	LF 2 x 8-inch cone HF 1 x 1-inch
<b>Driver Protection:</b>	DYNA-TECH protection circuitry
<b>Input Connection:</b>	NL4-compatible locking connector with terminal strip in parallel
<b>Controls:</b>	None
<b>Enclosure:</b>	Trapezoidal (22.5° included angle) 18mm, 11-ply cross-laminated birch
<b>Mounting/Rigging Provisions:</b>	9 x M6 threaded rigging fittings 4 x M6 threaded fittings for V-HSS 4 x M8 for third-party suspension products
<b>Finish:</b>	Catalyzed polyester two-part paint, black or white
<b>Grille:</b>	Powder coated steel, black or white finish
<b>Required Accessories:</b>	None
<b>Supplied Accessories:</b>	Yoke-style mounting bracket with optional 10° and 20° standoffs that allow a 10° or 20° downward or upward vertical tilt
<b>Optional Accessories:</b>	CMKIT ceiling mount kit V-HSS handle and stand socket VB-TILT tilting bracket VB-VY28 vertical yoke bracket M6EYBLTKIT 6mm eyebolt kit
<b>Dimensions—Height:</b>	25.5 inches (649 mm)
<b>Width:</b>	11.3 inches (287 mm)
<b>Depth:</b>	11.7 inches (298 mm)
<b>Weight (incl. bracket):</b>	36.7 lbs (16.7 kg) 38.7 lbs (17.7 kg) with autoformer
<b>Model Options:</b>	V2-28B (low impedance, black finish) V2-28W (low impedance, white finish) V2-28BT (built-in autoformer for 70V/100V applications, black finish) V2-28WT (built-in autoformer for 70V/100V applications, white finish)

### NOTES:

- Sensitivity: Free field pink noise measurement at 6ft (1.8m) at 10% power; extrapolated to 1 meter and an input of 2.83 volts RMS.
- Watts: All wattage figures are calculated using the rated nominal impedance.



## APPLICATIONS

- Houses of worship
- Restaurants, pubs, cafés
- Shopping malls, retail environments
- Airports
- Delay fill

## FEATURES

- DYNA-TECH™ driver protection circuitry
- Ferrofluid-treated HF driver for improved heat dissipation
- Carbon Ring Cone Technology provides 30% more piston area with increased excursion capability
- Constant-directivity rotatable square horn
- Frequency shaded woofers for smooth vertical pattern control
- Terminal strip and NL4-compatible connectors
- Available in standard black or white finishes
- Mounting yoke included with 10° and 20° vertical standoffs
- Optional V2-28T autoformer model for 70V/100V applications

## DESCRIPTION

The V2-28 is a two-way, full-range loudspeaker system suitable for use in a wide variety of fixed installations. This versatile unit is ideal for distributed systems such as those found in cafés, restaurants, shopping centers and airports. With its powerful dual cone drivers, the V2-28 provides additional low frequency and midrange output over that of its sister product, the V2-8. When paired with a subwoofer such as the V2-210S, a V2-28 system will produce high-fidelity, broad spectrum sound that belies its modest size. In addition to distributed systems, the V2-28 is an excellent choice for ancillary delay applications. When used to augment a front-of-house system in venues such as auditoria, theaters and houses of worship, delay loudspeakers can significantly even out the difference in sound pressure level from the front of the room to the rear of the room. Units may be positioned for underbalcony fill, overbalcony fill, or simply placed towards the rear of the seating areas. By deploying V2-28 loudspeakers in such a manner, the system designer will have far greater control over relative levels and relative tonal response when commissioning and equalizing the installation. The V2-28 may be mounted to a wall or ceiling surface using its included yoke bracket, suspended from its M6 threaded rigging points, or installed using a third-party mounting device. It includes a rotatable horn design that allows optimal dispersion in either vertical or horizontal mounting positions.

An optional model with a built-in 200W autoformer with taps at 200W, 100W, 50W and 25W (model V2-28T) is also available from the factory.

# V2-28

TWO-WAY, FULL-RANGE  
COMPACT LOUDSPEAKER SYSTEM,  
FREQUENCY SHADED LF



## FREQUENCY RESPONSE

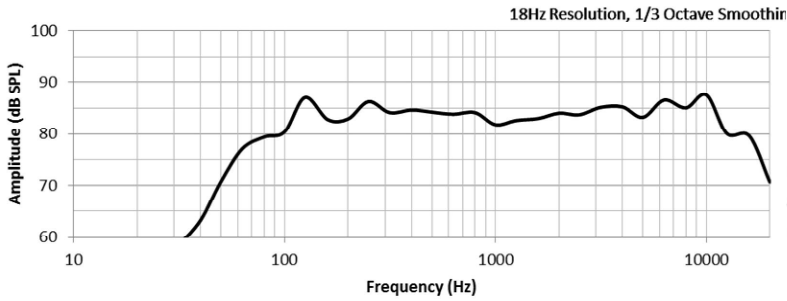

## IMPEDANCE

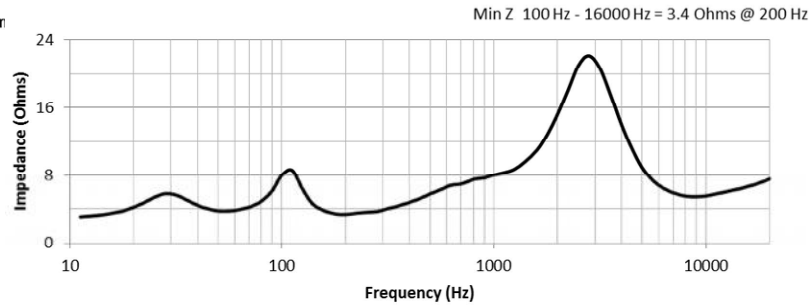

## BEAMWIDTH

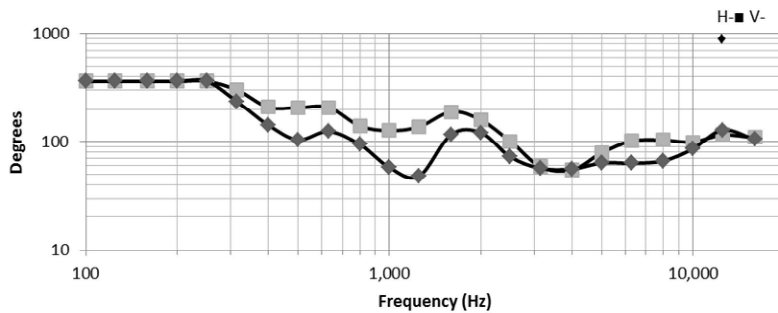

## AXIAL Q

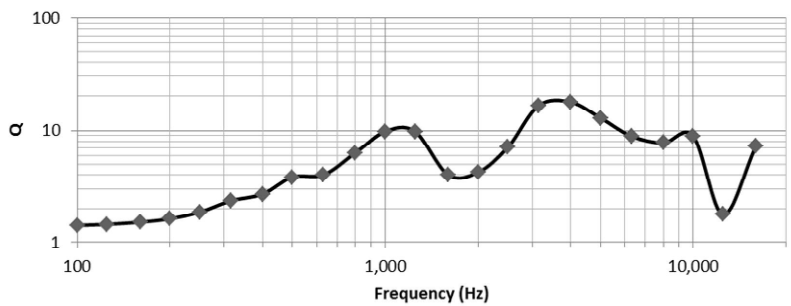

## DIMENSIONS

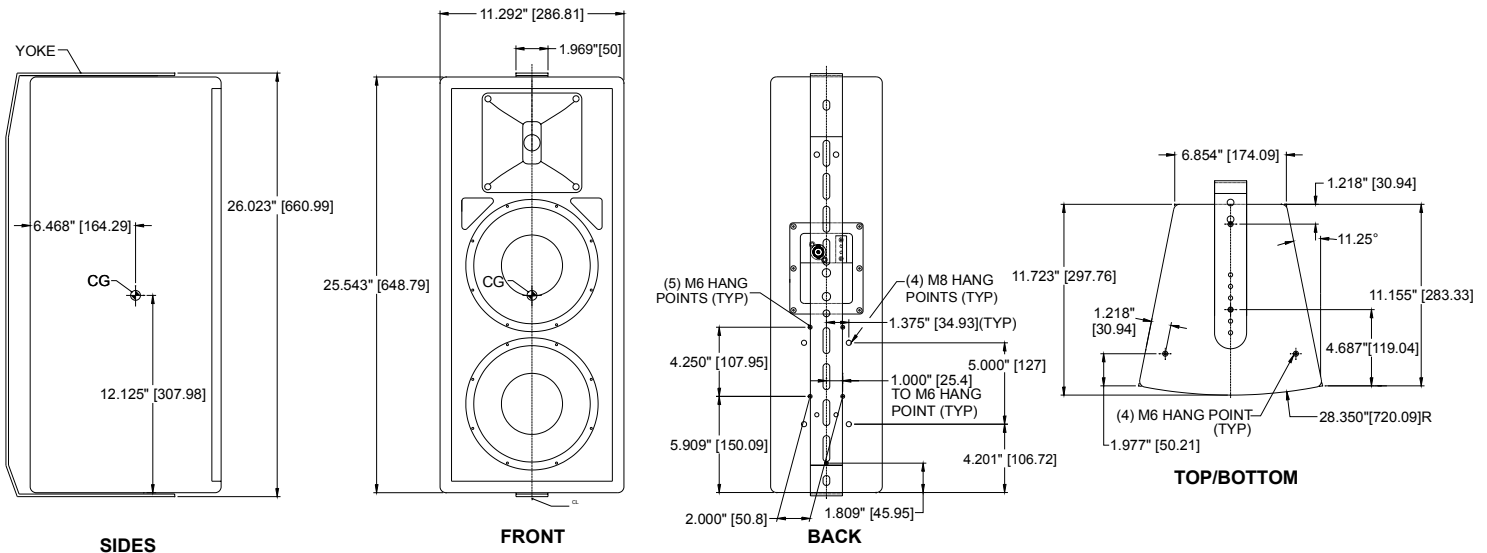

## ARCHITECTURAL SPECIFICATIONS

The loudspeaker system shall be a compact two-way, full-range, trapezoidal vented bass design with two 8-inch low frequency cone drivers and one 1-inch HF driver mounted to a rotatable 90° H x 70° V square horn. There shall be an NL4-compatible locking connector with terminal strip in parallel. The loudspeaker enclosure shall be constructed of 18mm, 11-ply cross laminated birch with a perforated steel grille and shall be fitted with thirteen M6 flying/rigging inserts. A steel mounting yoke with 10° and 20° vertical standoffs shall be included. The system shall have an amplitude response of 60 Hz to 18 kHz (-10 dB) and input capability of 34.6V RMS. The sensitivity at 1W/1m shall be 94 dB (100 Hz to 12.5 kHz). The nominal dispersion shall be 90° H x 70° V in vertical orientation. The loudspeaker dimensions shall be 25.5 in. (649 mm) H x 11.3 in. (287 mm) W (front) x 6.9 in. (174 mm) W (rear) X 11.7 in. (298 mm) D. The loudspeaker system and included mounting yoke assembly combined shall weigh 36.7 lbs (16.7 kg).

Community strives to improve its products on a continual basis. Specifications are therefore subject to change without notice.