



SPECIFICATIONS

Loudspeaker Type:	Compact two-way, full-range, trapezoidal, vented bass, user rotatable horn
Operating Range:	70 Hz to 18 kHz (-10 dB)
Frequency Response:	100 Hz to 16 kHz (± 3 dB)
Max Input Ratings:	150W continuous, 375W program 34.6 volts RMS, 69.2 volts momentary peak
Sensitivity (1W/1m):	92 dB (100 Hz to 12.5 kHz) free space
Maximum Output:	114 dB SPL / 120 dB SPL (peak)
Nominal Impedance:	8 ohms
Minimum Impedance:	6.1 ohms @ 180 Hz
Nominal -6dB Beamwidth:	90° H x 70° V (in vertical position)
Crossover Frequency:	1.3 kHz
Recommended Signal Processing:	90 Hz, 24 dB/octave Butterworth high pass filter
Drivers:	LF 1 x 8-inch cone HF 1 x 1-inch
Driver Protection:	DYNA-TECH protection circuitry
Input Connection:	NL4-compatible locking connector with terminal strip in parallel
Controls:	None
Enclosure:	Trapezoidal (22.5° included angle) 18mm, 11-ply cross-laminated birch
Mounting/Rigging Provisions:	9 x M6 threaded rigging fittings 4 x M6 threaded fittings for V-HSS and third-party suspension products
Finish:	Catalyzed polyester two-part paint, black or white
Grille:	Powder coated steel, black or white finish
Required Accessories:	None
Supplied Accessories:	Yoke-style mounting bracket with optional 10° and 20° standoffs that allow a 10° or 20° downward or upward vertical tilt
Optional Accessories:	CMKIT ceiling mount kit V-HSS handle and stand socket VB-TILT tilting bracket VB-VY8 vertical yoke bracket M6EYBLTKIT 6mm eyebolt kit
Dimensions—Height:	17 inches (433 mm)
Width:	11.3 inches (287 mm)
Depth:	11.7 inches (298 mm)
Weight (incl. bracket):	25.3 lbs (11.5 kg) 27.3 lbs (12.5 kg) with autoformer
Model Options:	V2-8B (low impedance, black finish) V2-8W (low impedance, white finish) V2-8BT (built-in autoformer for 70V/100V applications, black finish) V2-8WT (built-in autoformer for 70V/100V applications, white finish)

NOTES:

- Sensitivity: Free field pink noise measurement at 6ft (1.8m) at 10% power; extrapolated to 1 meter and an input of 2.83 volts RMS.
- Watts: All wattage figures are calculated using the rated nominal impedance.



APPLICATIONS

- Restaurants, pubs, cafés
- Houses of worship
- Shopping malls, retail environments
- Airports
- Delay fill

FEATURES

- DYNA-TECH™ driver protection circuitry
- Ferrofluid-treated HF driver for improved heat dissipation
- Carbon Ring Cone Technology provides 30% more piston area with increased excursion capability
- Constant-directivity rotatable square horn
- Terminal strip and NL4-compatible connectors
- Available in standard black or white finishes
- Mounting yoke included with 10° and 20° vertical standoffs
- Optional V2-8T autoformer model for 70V/100V applications

DESCRIPTION

The V2-8 is a two-way, full-range loudspeaker system suitable for use in a wide variety of fixed installations. Compact but powerful, it is ideal for distributed systems such as those found in cafés, restaurants, shopping centers and airports. When paired with a subwoofer such as the V2-210S, a V2-8 system will produce high-fidelity, broad spectrum sound that belies its modest size. The V2-8 is also an excellent choice for ancillary delay applications. When used to augment a front-of-house system in such venues as auditoria, theaters and houses of worship, delay loudspeakers can significantly even out the difference in sound pressure level from the front of the room to the rear of the room. Units may be positioned for underbalcony fill, overbalcony fill, or simply placed towards the rear of the seating areas. By deploying V2-8 loudspeakers in such a manner, the system designer will have far greater control over relative levels and relative tonal response when commissioning and equalizing the installation. The V2-8 may be mounted to a wall or ceiling surface using its included yoke bracket, suspended from its M6 threaded rigging points, or installed using a third-party mounting device. It includes a rotatable horn design that allows optimal dispersion in either vertical or horizontal mounting positions.

An optional model with a built-in 100W autoformer with taps at 100W, 50W, 25W and 12.5W (model V2-8T) is also available from the factory.

V2-8 TWO-WAY, FULL-RANGE COMPACT LOUDSPEAKER SYSTEM



FREQUENCY RESPONSE

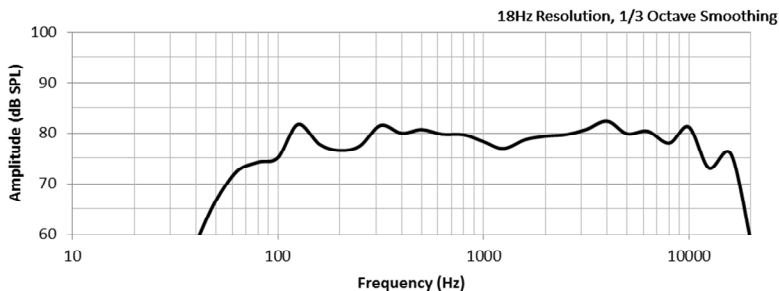

IMPEDANCE

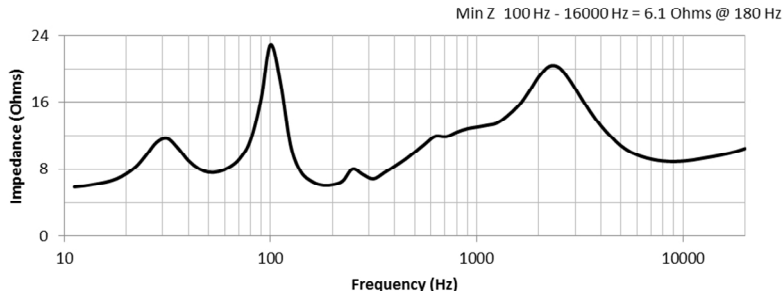

BEAMWIDTH

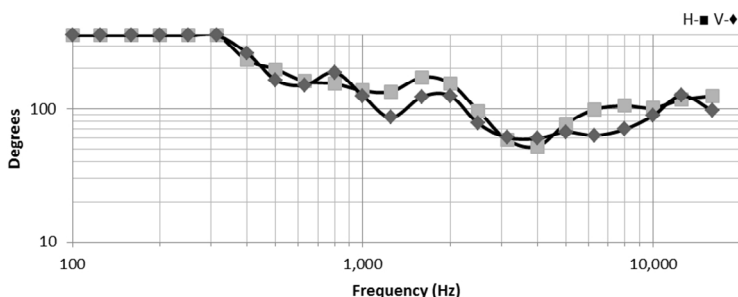

AXIAL Q

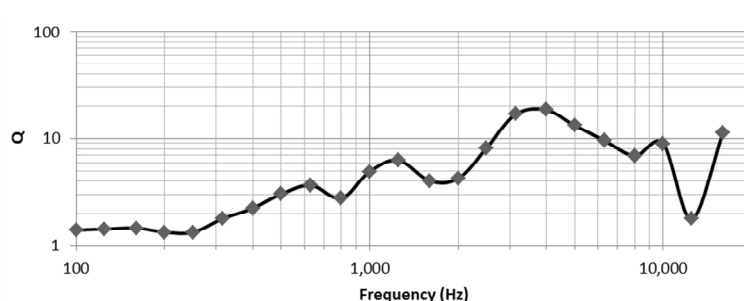

DIMENSIONS

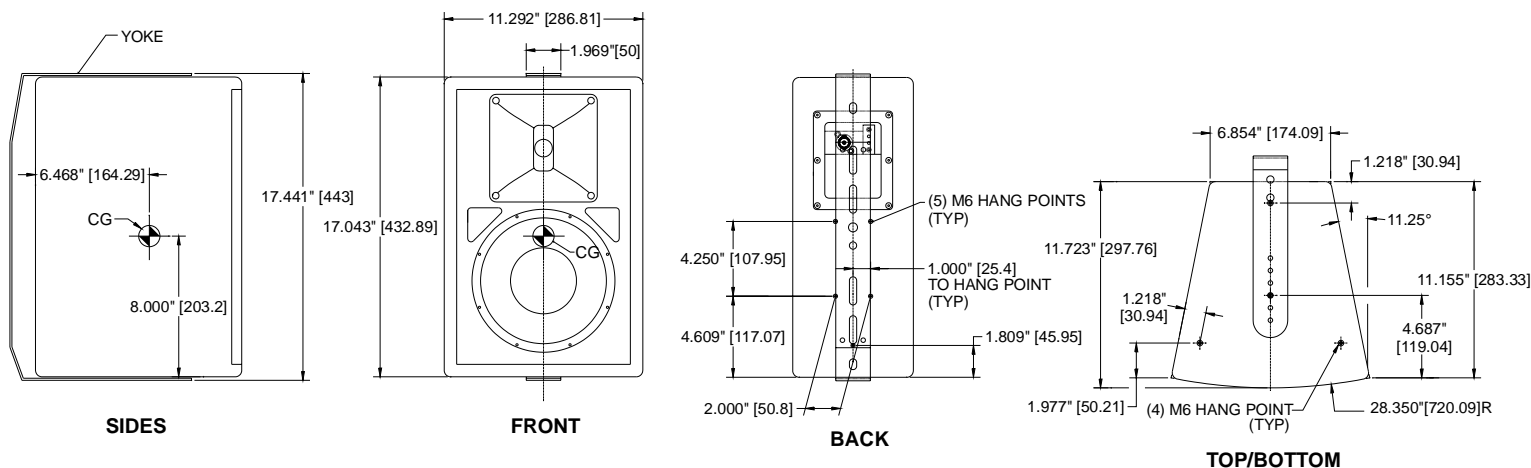

ARCHITECTURAL SPECIFICATIONS

The loudspeaker system shall be a compact two-way, full-range, trapezoidal vented bass design with one 8-inch low frequency cone driver and one 1-inch HF driver mounted to a rotatable 90° H x 70° V square horn. There shall be an NL4-compatible locking connector with terminal strip in parallel. The loudspeaker enclosure shall be constructed of 18mm, 11-ply cross laminated birch with a perforated steel grille and shall be fitted with thirteen M6 flying/rigging inserts. A steel mounting yoke with 10° and 20° vertical standoffs shall be included. The system shall have an amplitude response of 70 Hz to 18 kHz (-10 dB) and input capability of 34.6V RMS. The sensitivity at 1W/1m shall be 92 dB (100 Hz to 12.5 kHz). The nominal dispersion shall be 90° H x 70° V in vertical orientation. The loudspeaker dimensions shall be 17 in. (433 mm) H x 11.3 in. (287 mm) W (front) x 6.9 in. (174 mm) W (rear) X 17 in. (433 mm) D. The loudspeaker system and included mounting yoke assembly combined shall weigh 25.3 lbs (11.5 kg).

Community strives to improve its products on a continual basis. Specifications are therefore subject to change without notice.