

SD SWITCHER



Use the 600-Series to switch up to 8 SD source.

SE-600 Switcher - **\$2,000** MSRP

SE-600 Studio Kit - **\$6,650** MSRP

HS-600 Mobile Studio - **\$5,200** MSRP

*MSRP prices subject to change.

EFFECTS

TRANSITION

SETTING

ENTER

←

↓

→

MOSAIC

PAINT

BDR
CLR

600-Series

SD VIDEO SWITCHER + AUDIO MIXER

| SD |

Switch 8 Inputs

2

3

4

5

SUB

MAIN

USER

PIP

FZ

FTB

What Makes it Special

Purpose built, current technology design for SD switching and audio mixing. The 600-Series accepts six Composite Video and two DVI inputs. It may be upgraded to also include two SD-SDI outputs and two DV I/O ports.

Feature List

- Multi-View Output
- Integrated Audio Mixer
- Dual Picture-in-Picture
- Lumakey
- Upgradable to include 2x SD-SDI outputs and two DV I/O ports
- Compatible with TB-5 Tally Box
- Built-in Audio Delay

SD SWITCHER

SE-600 SD Switcher

The foundation of the 600-Series is the Datavideo SE-600 state of the art SD switcher. The SE-600 is designed to meet and exceed your expectations whether you're working in worship, education, or producing a live broadcast.

Thanks to the built-in time base correctors and frame syncs, the SE-600 enables you to switch seamlessly between inputs and blend high-quality content on the fly. And, with the optional DV board, users can have two extra DV and two extra SD-SDI outputs.

SE-600 SD Studio Kit

The SE-600 is available in a studio kit that comes with a few extra goodies to help you get up and running in no time! Included with the SE-600 is the DN-700 Hard Drive Recorder, the ITC-100 Intercom & Tally System with 4x Headsets, Belt Packs, and Tally Lights, and the TLM-170H



SE-600 Switcher »

17" Desktop Monitor with the CB-20 DVI-D-to-HDMI Cable (for connecting the monitor to the switcher). The hardware is mounted securely and neatly using the included RKM-2000 Desktop Holder.

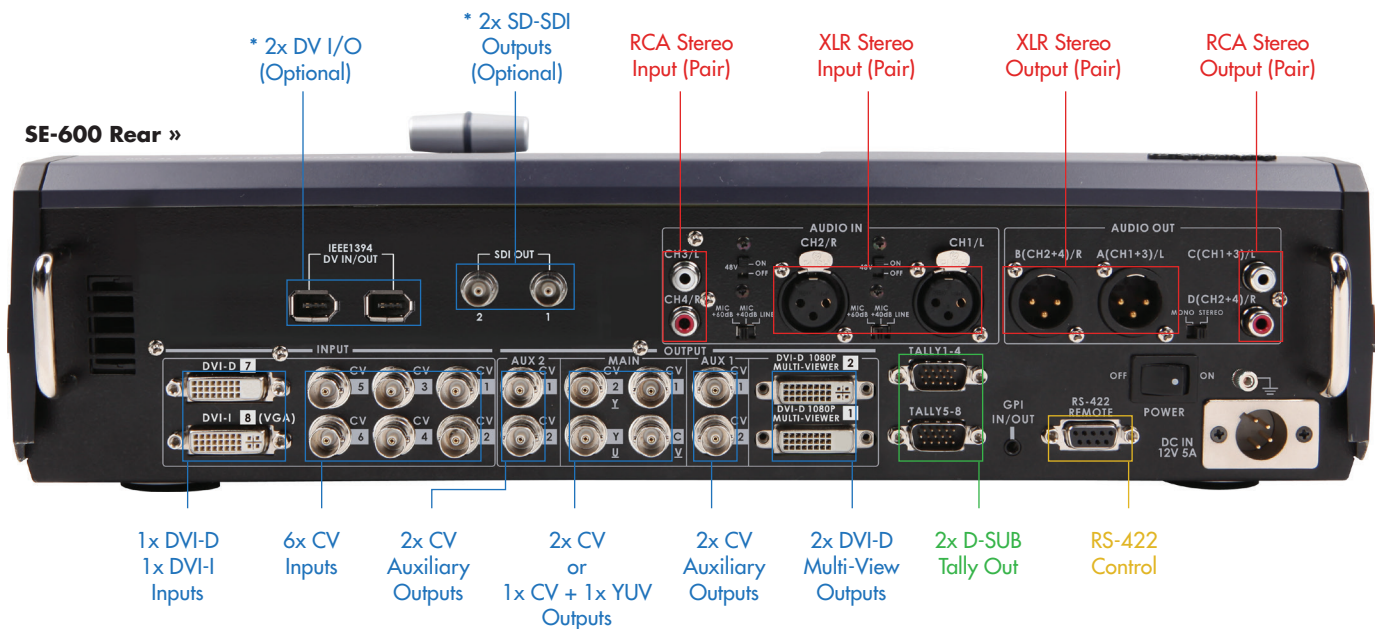

■ Video ■ Audio ■ Control ■ Tally * DV & SDI Ports available with optional DV board

HS-600 SD Mobile Studio

The SE-600 Switcher is available as a Mobile Studio – a plug-and-play set inside a tidy case that can be carried by hand. It is small enough to be carried onto most airplanes. The lightweight HS-600 Mobile Studio includes the features of the SE-600 Switcher, an eight-channel wired intercom and tally system, and a multi-view 17" high quality screen.

Integrated Audio Mixer

The 600-Series' switchers include a built-in three input with master gain audio mixer.

Dual Picture-in-Picture

The 600-Series allows for dual PiP images, displayed over the main program output. With this feature, you can have one large video with two smaller ones on top. Any one or two of the images could be from a computer.

Lumakey

Both the SE-600 and the HS-600 offer a switcher with Lumakey capabilities, which allows CG elements to be displayed above the main footage. For instance, graphics from a PowerPoint presentation can be sent by a computer to the switcher's DVI port and used to display captions in the program output.

Of course with the Datavideo CG's you can also insert text, etc through the DSK (Down Stream Keyer).

The 600-Series is made with powerful features, such as an integrated audio mixer, dual PiP, Lumakey, and assignable auxiliary outputs.



« HS-600
Mobile Studio

The Ins & Outs

The video inputs on the 600-Series include six Composite Video ports, one DVI-D port, and one DVI-I port. As for the main video outputs, there are two CV ports and one YUV set. The YUV set, if used, will consume one CV port, providing a total of one YUV set and one available CV port. If the YUV set is not used, there will be two available CV ports for program output. There are also four assignable CV auxiliary outputs. As an optional bonus, the 600-Series may be upgraded with the Datavideo DV Board, which adds two SD-SDI output ports and two DV in-and-out ports. Lastly, the SE-600 and HS-600 include two DVI-D outputs to display a multi-view preview screen on one or two monitors.

For audio, the 600-Series is made with two XLR inputs, functioning as a stereo pair. There are also two RCA inputs, serving as the auxiliary pair. The audio outputs also include two XLR ports and two RCA outputs, both serving as stereo pairs.

Expanding the System



DAC-50 – Adding this into your production system will allow the use of HD/SD-SDI devices with the 600-Series. It will accept a single SDI input and convert it to YUV, which can then be sent to the switcher. The DAC-50's built-in scaler allows conversion from HD-SDI in 1080i & 720p and SD-SDI in 1080i, 720p, 480i, and 576i.



CG-100 – A computer equipped with the CG-100 software may be used to embed text and graphics into the video.



TP-100 or TP-300 can provide a teleprompting solution for hosts, interviewers, and other talent. The TP-100 integrates with the iPhone® or Android® Phone, while the TP-300 functions using the iPad® or Android® Tablet.



CASDI-50, 100, and 150 are **BNC cables** that come in lengths of 50, 100, and 150-feet, respectively.



The **DN-200 Recorder** may be used to save your footage. It plugs directly into the SE-600's CV output to save video, and it saves audio via Stereo RCA connection.



ITC-100 -- Integrate the system with the SE-600 to give your crew tally lights and communication. The ITC-100 plugs into the back of the SE-600 for easy tally setup, and it includes four belt-packs, tally lights, and headsets.



TB-5 – Need a tally light solution without the intercom system? Two TB-5s plug directly into the switcher's tally-out ports for a quick and easy setup. 8x tally lights (included) plug into each TB-5 using 3.5mm cables. The system is fully synched with the switcher's Program and Preview selections. Tally lights will illuminate amber for "up next" and red for "live."

Connecting the SE-600

The diagram on the next page shows one of the many possible production configurations using the SE-600 Switcher. The difference between this diagram and one made with the HS-600 Mobile Studio is that the latter package includes a built-in monitor and intercom/tally system, whereas the SE-600 is a switcher only.

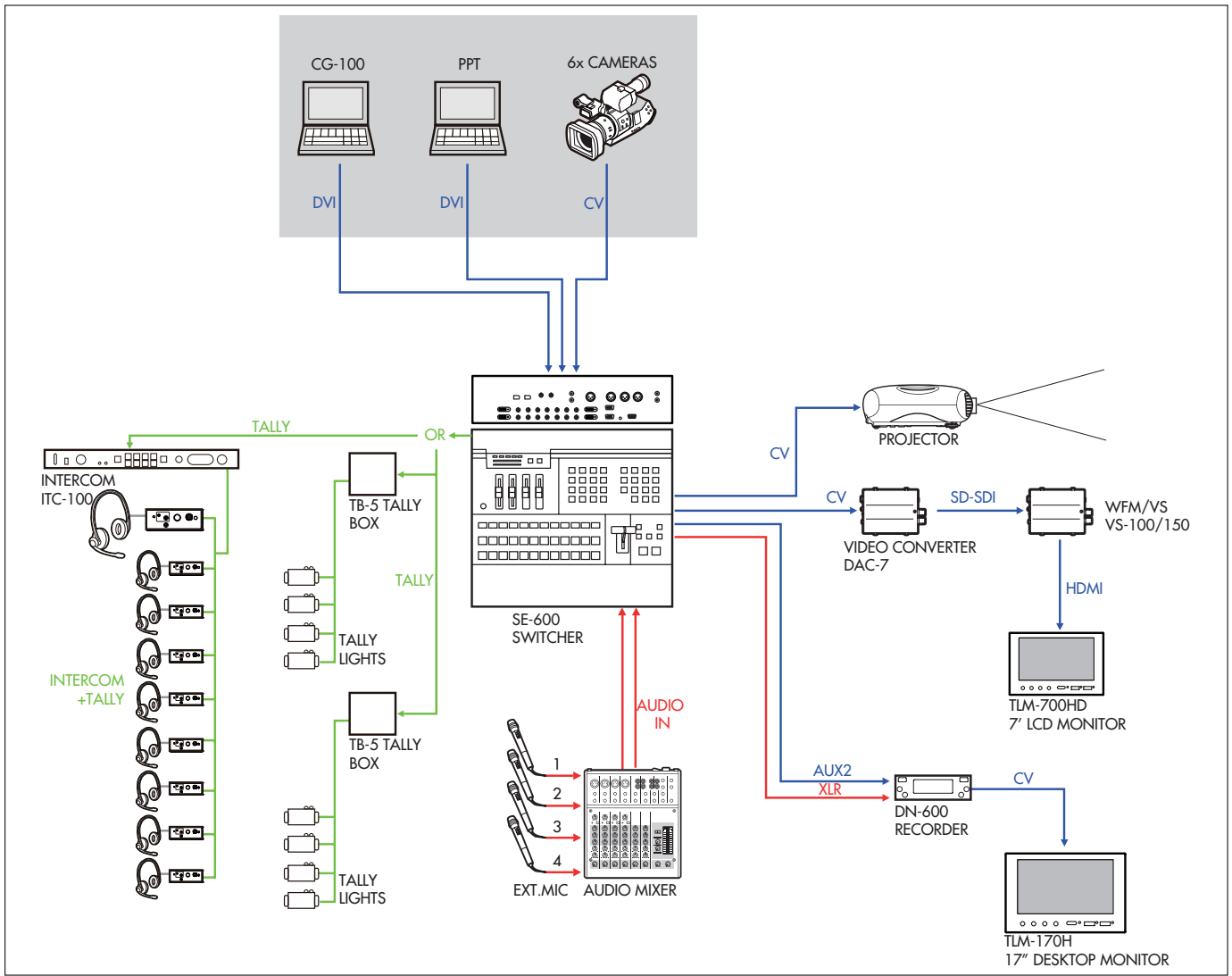

600-Series Specifications

	SE-600 Switcher	SE-600 Switcher Kit	HS-600 Mobile Studio
Video Inputs*	6x Composite Video / 1x DVI-D / 1x DVI-I		
Video Outputs	[2x Composite Video... OR... 1x Composite Video + 1x YUV] / 4x Composite Video (Auxiliary) / 2x DVI-D to Multi-View (PVW)		
Audio Inputs	2x XLR (One Stereo Pair)	2x XLR (One Stereo Pair)	2x XLR (One Stereo Pair)
Audio Outputs	2x RCA (One Stereo Pair)	2x RCA (One Stereo Pair)	2x RCA (One Stereo Pair)
Tally	2x D-SUB Output	ITC-100 Intercom/Tally System with 4x Tally Lights, Headsets, and Belt Packs	2x D-SUB Output
Intercom	n/a	ITC-100 Intercom/Tally System with 4x Tally Lights, Headsets, and Belt Packs	n/a
Control	RS-422, GPI	RS-422, GPI	RS-422, GPI
Monitor	n/a	TLM-170H 17" Desktop Monitor	Integrated 17" Monitor
Recorder	n/a	DN-700 Hard Drive Recorder	n/a
Cables	n/a	CB-20 DVI-D to HDMI Cable	n/a
Casing	n/a	RKM-2000 Desktop Holder	Metal
Special Notes*	*The 600-Series may be upgraded, adding 2x SD-SDI outputs and 2x DV I/O ports.		