

# PA820, PA778x Series

# RG59 Splitter and Panels

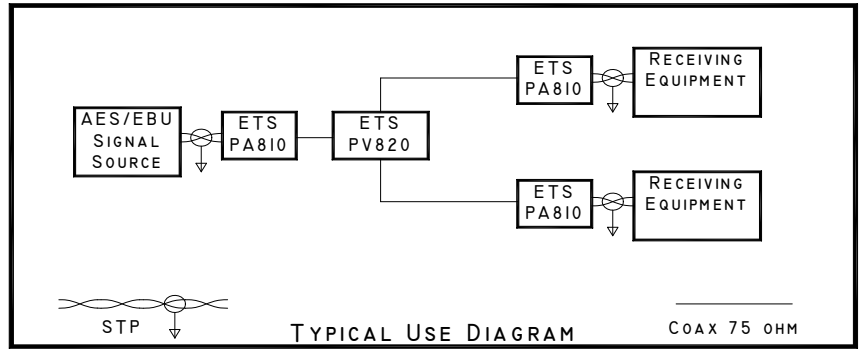

| Features/Advantages   | Description   | Applications  |
|---|---|---|
| <ul style="list-style-type: none"> <li>Enables two outputs from a single source without interference or impedance-mismatching</li> <li>Individual splitters or rack-mountable panel versions</li> <li>Panel mount models available from 2 to 12 channels</li> <li>Can be cascaded non-symmetrically for multiple outputs</li> <li>Metal case and chassis</li> <li>Made in USA</li> <li>100% tested</li> </ul> | <p>The <b>ETS PA820 RG59 Splitter</b> and the <b>PA778x Series of AES/EBU Splitter Panels</b> are carefully designed to divide the energy from a single source into equal parts, maintaining precise impedance-matching. Return signals are routed back to the source with minimal crosstalk to the other port.</p> <p>These devices are expressly crafted for AES/EBU standard for digital audio. They minimize losses while preserving signal integrity. As an added benefit, ETS precision impedance-matching technology enables units to be non-symmetrically applied when being cascaded. Note that each cascade stage reduces the signal level by 3 dB.</p> | <ul style="list-style-type: none"> <li>Broadcast Control Rooms</li> <li>Recording Studios</li> <li>Post Production Facilities</li> <li>Satellite TV Facilities</li> </ul> |

| Specifications |  | Product Ordering Information |  |
|----------------|--|------------------------------|--|
| Bandwidth      | 10 kHz to 50 MHz                                       | PA820                        | RG59 Splitter, (1) FBNC in, (2) FBNC out |
| Connectors     | (3) BNC female 75Ω (per chan. on panels)               | PA778-4                      | RG59 Splitter Panel, 4 channels          |
| Impedance      | 75Ω +/- 2% 50 kHz to 30 MHz                            | PA778-8                      | RG59 Splitter Panel, 8 channels          |
| Insertion Loss | 0.25 dB 10 kHz to 50 MHz                               | PA778-12                     | RG59 Splitter Panel, 12 channels         |
| Note:          | Splitting reduces signal level by 3 dB                 |                              |  |
| Crosstalk      | 35 dB down 50 kHz to 30 MHz                            |                              |  |
| Dimensions     | Panels: 1 RU x 80mm deep<br>Baluns: 69mm x 69mm x 33mm |                              |  |
| Net Weight     | Panels: 0.64 to 1.04 kg; Splitter: 0.1 kg              | X = number of channels       |  |

© Copyright 2001-2011 Energy Transformation Systems, Inc.  
 FatCat5 System panels and information outlets protected under US Patent Number 6,123,577. FatCat5™, FatCat5 System™, Chameleon Color Coding System™, Balanced Star™, Balanced Line™, Monoline™ and Precision Wave™, InstaSnake™, CineSnake™ are trademarks of Energy Transformation Systems. All other brand or product names are or may be trademarks of, and are used to identify the products or services of their respective owners.  
 Revised 10/13/2011



**Energy Transformation Systems, Inc.**  
 43353 B Osgood Road, Fremont, CA 94539  
 www.etslan.com  
 800-752-8208 510-656-2012 Fax 510-656-2026

