

Professional Series

## Key Features:

- ▶ 50 Hz to 20 kHz Frequency Range
- ▶ High Sensitivity, 91 dB SPL, 1 W, 1 m (3.3 ft)
- ▶ High Power Handling Capability: 150 watts continuous pink noise
- ▶ Internal Thermomaster® technology allows for unprecedented high frequency power in a compact molded enclosure.
- ▶ Convenient mounting design uses JBL QuickMount™, Omnimount® or APC Multimount brackets
- ▶ Special cabinet shape incorporates 20° angled front baffle
- ▶ SMPTE/ISO2969 Curve X high frequency de-emphasis
- ▶ Lightweight, rigid molded enclosure
- ▶ Input terminals located on top of cabinet for quick access
- ▶ Uniform horizontal and vertical coverage
- ▶ THX® Approved

The 8320 Cinema Surround Speaker offers high power handling, high sensitivity, and extended bass response in a very compact enclosure. The two-way 8320's reliability and performance features position it as the ideal low cost, compact surround for the extended dynamic range required by digital sound formats.

The 8320 features a high power, long-throw 200 mm (8 in) low frequency driver for smooth, extended bass response. The high frequency section combines a 25 mm (1 in) diameter soft dome driver with a constant coverage horn for very high output capability and wide, even high frequency coverage. The 150 watt continuous power rating (600 watt peak) provides extended dynamic range required for digital soundtracks with absolute reliability.

Its modern, molded black textured enclosure with black grille enhances any decor.

JBL's QuickMount bracket allows one person to quickly and simply mount the very lightweight enclosure on a previously installed bracket half.

Built to traditional JBL quality standards, the 8320 will stand up to long-term use under adverse conditions while delivering excellent performance.

Omnimount is a registered trademark of Omnimount Systems.

THX is a trademark of THX Ltd. which may be registered in some jurisdictions. All rights reserved.



## Specifications:

System:

Frequency Range (-10 dB):	50 Hz - 20 kHz
Frequency Response (±3 dB):	65 Hz - 18 kHz
Power Rating <sup>1</sup> :	150 watts continuous pink noise, 600 watts peak
Sensitivity (1W/1m) <sup>2</sup> :	94 dB-SPL half-space / wall-mounted 91 dB-SPL free-field
Maximum Peak SPL <sup>3</sup> :	122 dB/1m
Nominal Impedance:	8 ohms
Hor. Coverage Angle (-6 dB):	100° averaged 400 Hz to 12 kHz
Vert. Coverage Angle (-6 dB):	90° averaged 400 Hz to 12 kHz
Directivity Factor (Q):	7 averaged 400 Hz to 12 kHz
Directivity Index (DI):	8.4 dB averaged 400 Hz to 12 kHz
Crossover Frequency:	3 kHz
High Frequency Contour:	ISO2969 Curve X surround contour
Polarity:	EIA (Positive voltage to RED terminal gives forward cone motion)

Low Frequency Transducer:

Nominal Diameter:	200 mm (8 in) 38 mm (1.5 in) voice coil
-------------------	--

High Frequency Transducer:

Nominal Diameter:	25 mm (1 in) 25 mm (1 in) voice coil
-------------------	---

Physical:

Downward Firing Angle:	Nominal 20° when mounted flush on back panel
Enclosure Material:	Textured Black H.I.P.S. Plastic
Grille Color:	Black
Input Connectors:	5-way binding posts
Dimensions (H x W x D):	406 mm x 343 mm x 224 mm 16 in x 13.5 in x 8.8 in
Net Weight:	5.0 kg (11 lb)

<sup>1</sup>Rating based on test signal of IEC filtered random noise with a peak-to-average ratio of 6 dB, two hours duration.

<sup>2</sup>Average measured free-field and half-space sensitivity at 2.83V/1m from 200 Hz to 3 kHz.

<sup>3</sup>Calculated maximum SPL based on rated power handling and half-space sensitivity.

JBL continually engages in research related to product improvement. Some materials, production methods and design refinements are introduced into existing products without notice as a routine expression of that philosophy. For this reason, any current JBL product may differ in some respect from its published description, but will always equal or exceed the original design specifications unless otherwise stated.

# ► 8320 Compact Cinema Surround Speaker for Digital Applications

Frequency Response in half-space ( $2\pi$ , solid line) and free-field ( $4\pi$ , dotted line), and Input Impedance

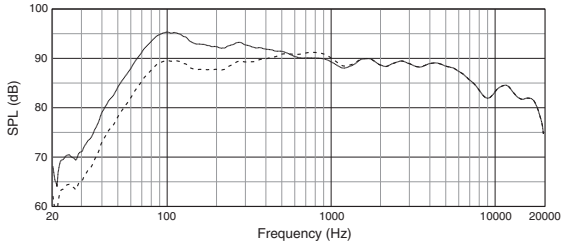

Beamwidth vs. Frequency

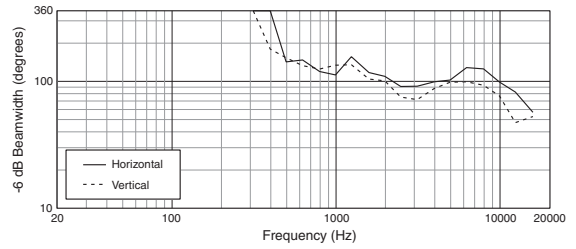

Horizontal Off-Axis Frequency Response

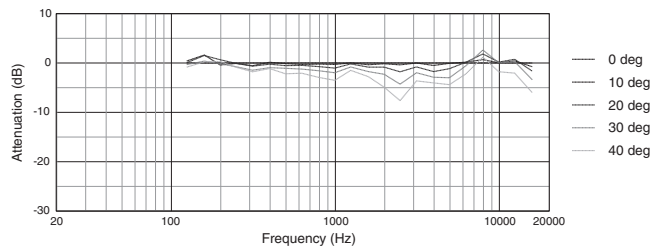

Vertical Off-Axis Frequency Response (down)

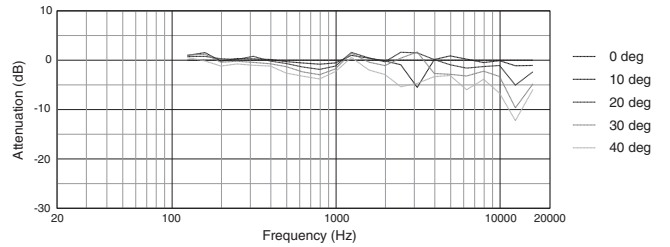

Impedance

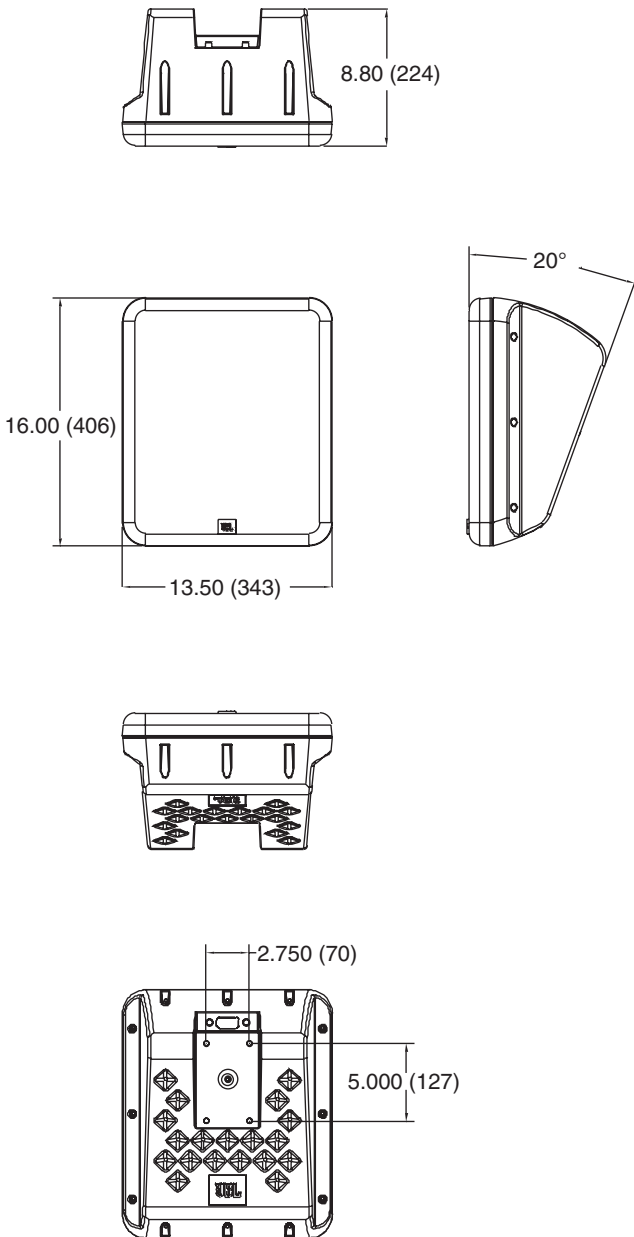
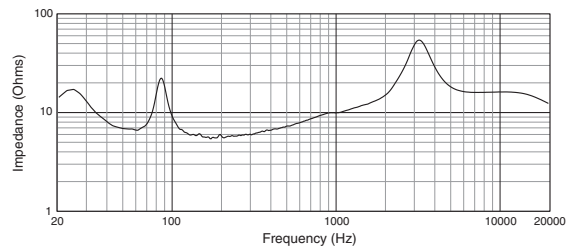

JBL Professional  
8500 Balboa Boulevard, P.O. Box 2200  
Northridge, California 91329 U.S.A.

■ A Harman International Company  
© Copyright 2008 JBL Professional

SS 8320  
CRP 5M  
08/08