

# RemoteMix 2™

## Broadcast Field Mixer



### FEATURES

	<b>2</b>	<b>3.5</b>	<b>4</b>
» XLR Mic Jacks	2	3	4
» Switchable 48 Volt Phantom Power for each Mic Input			•
» Mic/Line Pad: On Channel	2	3	3,4
» ¼" Headphone Jacks with Individual Level Controls	2	3	4
» 3.5 mm Send and Receive Jacks	•	•	•
» LED VU Meter	•	•	•
» Phone Line Hybrid with DTMF Keypad with Redial	•	•	•
» Universal PBX Handset Interface		•	•
» Wired Phone Headset Interface (2.5mm & 3.5mm Interfaces)	•	•	•
» Bluetooth Wireless Technology		•	•
» Bass Boost			•
» Dual 9 Volt Batteries	•	•	•
» 100-240 VAC External AC Power Supply	•	•	•

**The Handy, Compact Mixer.** RemoteMix 2 is a two-channel field mixer / headphone amplifier that's a little more hands-on in the remote broadcast environment. We've tightened the belt on this one. It may be smaller but we didn't skimp out on the good stuff. RemoteMix 2 provides a communications interface for remote broadcast, IFB, or a backup audio path. The integrated headphone amplifier provides sidetone to monitor all inputs as well as an external feed. RemoteMix 2 features a phone line hybrid with keypad along with a wired notebook/cell phone headset interface. These parts were designed to work together, saving setup time and wiring in the field.

**TV- Use a Phone Line for Real Time Production Monitoring.** RemoteMix 2 Combines a small front-end mixer with two powerful ¼" headphone outputs. Send and receive interview audio while pulling IFB off the phone line, cell phone or notebook.

**Radio- Perfect for Live Remotes.** Use it as a front-end mixer for your POTS, ISDN, IP or Smart Phone Codec. Or, use it as a phone line hybrid, calling in to your studio talk show hybrid.

Remote Mix 3.5 and RemoteMix 4 shown for comparison  
**2** =RemoteMix 2, **3.5** =RemoteMix 3.5, **4** =RemoteMix 4



# RemoteMix 2™

## Broadcast Field Mixer



### REAR VIEW

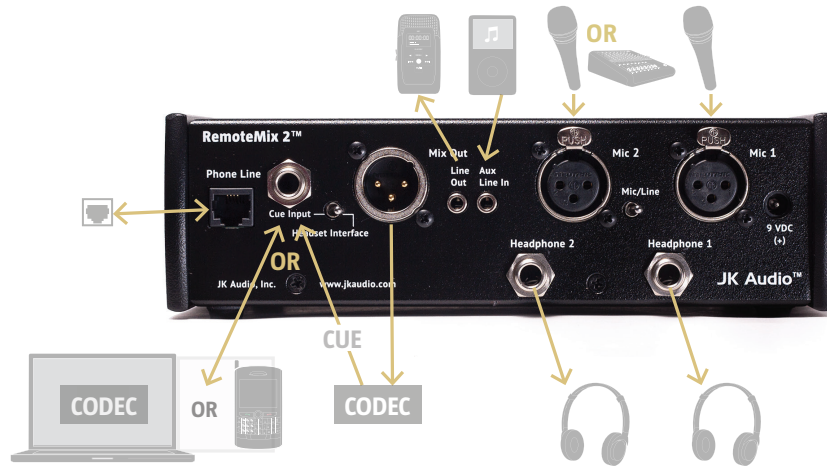

### BLOCK DIAGRAM

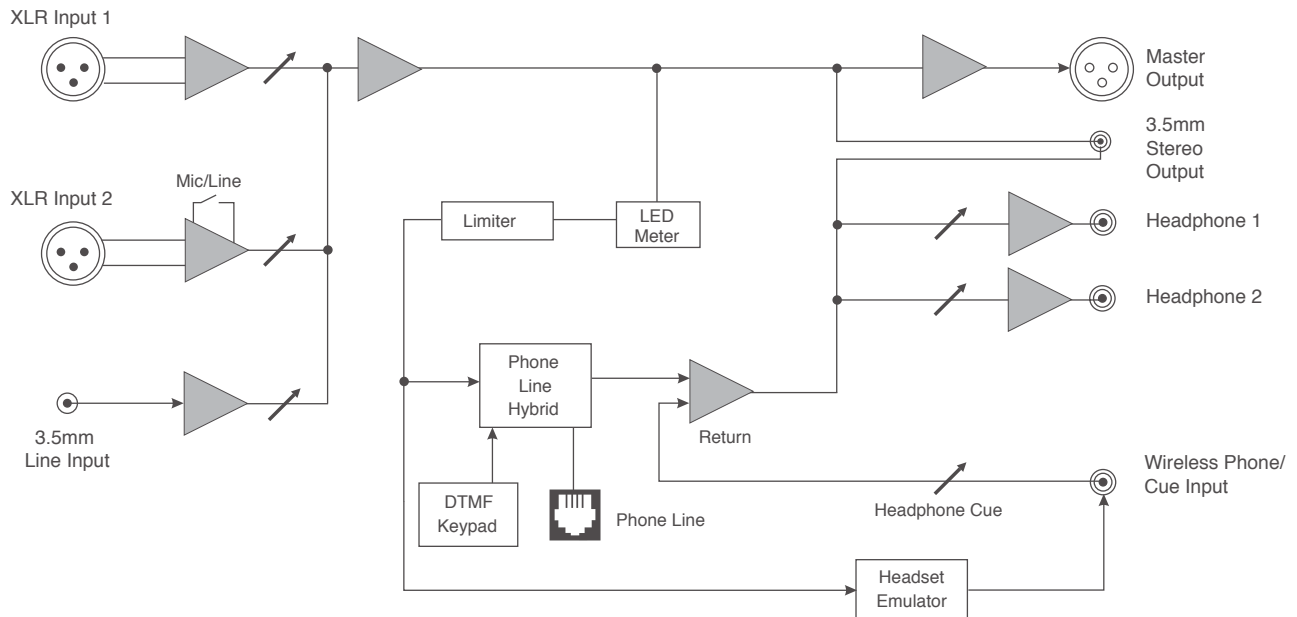

### SPECIFICATIONS

#### Input

<b>Female XLR Mics:</b>	2k ohms / -25 dBu nom (Mic/Line pad switch = +6 dBu max)
<b>1/8" (3.5mm) Stereo Line:</b>	20k ohms / -10 dBu nom
<b>Headphone Cue 1/4":</b>	20k ohms / -10 dBu nom

#### Output

<b>Balanced Male XLR:</b>	+16 dBu max, 20 Hz - 20 kHz, +/- 1dB
<b>1/8" (3.5mm) Stereo:</b>	100 ohms / -10 dBu nom
<b>Headphone 1/4" Stereo:</b>	8 ohms / 1/3 watt per channel

<b>Phone Line Connector:</b>	RJ11C
<b>Ringer:</b>	0.5B REN
<b>Isolation:</b>	3750 VAC
<b>Power:</b>	100-240 VAC, 50-60Hz or Two 9 VDC batteries
<b>Size:</b>	7.75" x 6.5" x 2.3"

