

Accessories



male



female

FGG-EGG Insulators

Insulators for 2B-5B and 2K-5K series vary according to the fibre optic contact type chosen.

They are only necessary as replacement item when electrical crimp contacts are available.

	FO Contact		Insulator part number	
	Type F1		Male contact	Female contact
2B 2K	96A		FGG.2B.302.XLY	EGG.2B.402.XLY
	96C		FGG.2B.304.XLY	EGG.2B.404.XLY
	96E		FGG.2B.306.XLY	EGG.2B.406.XLY
	96J		FGG.2B.310.XL	EGG.2B.410.XL
3B 3K	07A		FGG.3B.302.CL	EGG.3B.402.CL
	96X		FGG.3B.322.XL	EGG.3B.422.XL
	97C		FGG.3B.344.XL	EGG.3B.444.XL
	97E		FGG.3B.346.XL	EGG.3B.446.XL
	97J		FGG.3B.350.XL	EGG.3B.450.XL
	97R		FGG.3B.356.XL	EGG.3B.456.XL
4B 4K	07C		FGG.4B.304.CL	EGG.4B.404.CL
	99H		FGG.4B.379.XL	EGG.4B.479.XL
	97F		FGG.4B.347.XL	EGG.4B.447.XL
	97L		FGG.4B.352.XL	EGG.4B.452.XL
	97R		FGG.4B.356.XL	EGG.4B.456.XL
	97T		FGG.4B.358.XL	EGG.4B.458.XL
	98E		FGG.4B.366.XL	EGG.4B.466.XL
	98L		FGG.4B.385.XL	EGG.4B.485.XL
5B 5K	07J		FGG.5B.340.CL	EGG.5B.440.CL

	FO Contact		Insulator part number	
	Type F2		Male contact	Female contact
2B 2K	92A		FGG.2B.302.EL	EGG.2B.402.EL
	92C		FGG.2B.304.EL	EGG.2B.404.EL
	92E		FGG.2B.306.EL	EGG.2B.406.EL
	92J		FGG.2B.310.EL	EGG.2B.410.EL
3B 3K	03A		FGG.3B.302.EL	EGG.3B.402.EL
	92X		FGG.3B.322.EL	EGG.3B.422.EL
	93B		FGG.3B.344.EL	EGG.3B.444.EL
	93E		FGG.3B.346.EL	EGG.3B.446.EL
	93J		FGG.3B.350.EL	EGG.3B.450.EL
	93R		FGG.3B.356.EL	EGG.3B.456.EL
	87E		FGG.3B.376.WL	EGG.3B.476.WL
	87R		FGG.3B.386.WL	EGG.3B.486.WL
4B 4K	03C		FGG.4B.304.EL	EGG.4B.404.EL
	95D		FGG.4B.375.EL	EGG.4B.475.EL
	93E		FGG.4B.346.EL	EGG.4B.446.EL
	93L		FGG.4B.352.EL	EGG.4B.452.EL
	93R		FGG.4B.356.EL	EGG.4B.456.EL
	93T		FGG.4B.358.EL	EGG.4B.458.EL
	94E		FGG.4B.366.EL	EGG.4B.466.EL
	94L		FGG.4B.385.EL	EGG.4B.485.EL
	05C		FGG.4B.304.WL	EGG.4B.404.WL
	88E		FGG.4B.366.WL	EGG.4B.466.WL
5B 5K	03J		FGG.5B.340.EL	EGG.5B.440.EL
	03N		FGG.5B.354.EL	EGG.5B.454.EL
	956		FGG.5B.356.WLL	EGG.5B.456.WLL
	94B		FGG.5B.383.EL	EGG.5B.483.EL



FGG-EGG Crimp electrical contacts

	FO Contact		ø A Contact LV	Contact part number	
	Types			Male	Female
	F1	F2			
2B 2K	96A	92A	0.9	FGG.2B.560.ZZC	EGG.2B.660.ZZM
	96C	92C	0.7	FGG.2B.555.ZZC	EGG.2B.655.ZZM
	96E	92E	0.7	FGG.2B.555.ZZC	EGG.2B.655.ZZM
	96J	92J	0.7	FGG.2B.555.ZZC	EGG.2B.655.ZZM
3B 3K	97C	93B	0.9	FGG.3B.560.ZZC	EGG.3B.660.ZZM
	97E	93E	0.9	FGG.3B.560.ZZC	EGG.3B.660.ZZM
	-	87E	0.9	FGG.3B.560.ZZC	EGG.3B.660.ZZM
	97J	93J	0.7	FGG.3B.555.ZZC	EGG.3B.655.ZZM
	97R	93R	0.7	FGG.3B.555.ZZC	EGG.3B.655.ZZM
	96X	92X	0.7	FGG.3B.555.ZZC	EGG.3B.655.ZZM
	-	87R	0.7	FGG.3B.555.ZZC	EGG.3B.655.ZZM

	FO Contact		ø A Contact LV +HV	Contact part number	
	Types			Male	Female
	F1	F2			
4B 4K	-	95D	1.3	FGG.4B.565.ZZC	EGG.4B.665.ZZM
	-	93E	1.3 ¹⁾	FGG.4K.565.ZZCY	EGG.3B.665.ZZM
	-		0.9	FGG.4B.560.ZZC	EGG.4B.660.ZZM
	97F	-	1.3	FGG.4B.565.ZZC	EGG.4B.665.ZZM
	97R	93R	0.9	FGG.4B.560.ZZC	EGG.4B.660.ZZM
	97L	93L	0.9	FGG.4B.560.ZZC	EGG.4B.660.ZZM
	98L	94L	0.7	FGG.4B.555.ZZC	EGG.4B.655.ZZM
	97T	93T	0.7	FGG.4B.555.ZZC	EGG.4B.655.ZZM
	-	88E	0.7	FGG.4B.555.ZZC	EGG.4B.655.ZZM
	99H	-	0.7	FGG.4B.555.ZZC	EGG.4B.655.ZZM
98E	94E	0.7	FGG.4B.555.ZZC	EGG.4B.655.ZZM	
5B 5K	-	94B	2.0	FGG.5B.575.ZZC	EGG.5B.675.ZZM
	-	956	2.0 ¹⁾	FGG.3B.575.ZZC	EGG.4B.675.ZZM
	-		1.6 ¹⁾	FGG.4B.570.ZZC	EGG.2B.670.ZZM
	-	90C	1.6 ¹⁾	FGG.4B.570.ZZC	EGG.2B.670.ZZM

Note: 1) Arrangements with special contact length.

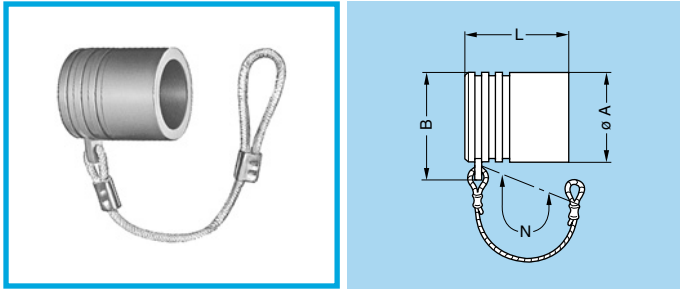

- Body material: Polyoxymethylene (POM) grey (or black)
- Cord material: Polyamide 6, grey (or black)
- Crimp ferrule material: Nickel-plated brass
- Gasket material: Silicone rubber
- Maximum operating temperature: 100°C
- Watertightness: IP61 according to IEC 60529

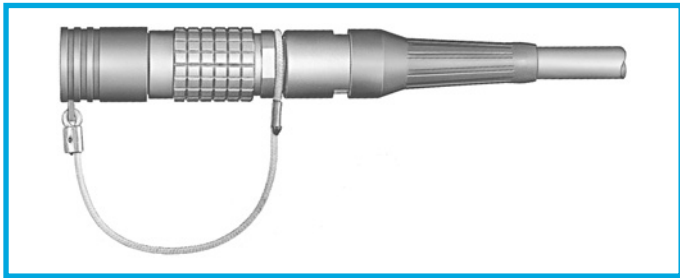

BFG Plug caps

Part number	Series	Dimensions (mm)			
		A	B	L	N
BFG.00.100.PCSG	00	7.5	9.8	10.0	60
BFG.0B.100.PCSG	0B	9.5	12.0	12.2	85
BFG.2B.100.PCSG	2B	15.0	18.0	15.0	85
BFG.3B.100.PCSG	3B	18.5	22.0	18.5	95

Note: This cap is available only with an alignment key (G). Upon request this cap can be supplied in black and the last letter «G» of the part number should be replaced with «N».

Fitting the cord

Slide the plug into the loop of the cord. Place the loop into the groove in front of the collet nut and tighten the loop.

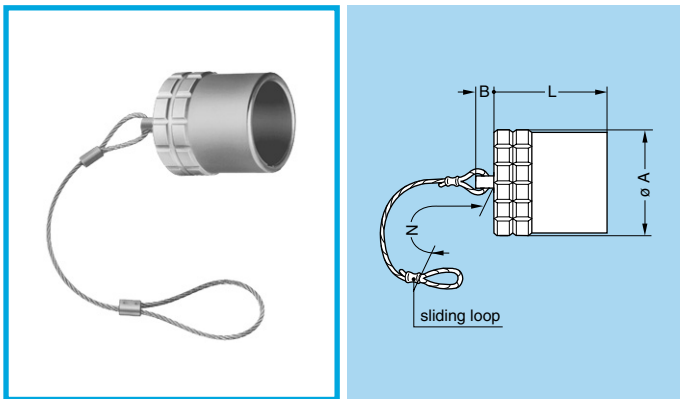

- Body material: Nickel-plated brass (Ni 3µm)
- Lanyard material: Stainless steel
- Crimp ferrule material: Nickel-plated brass + polyolefin
- O-ring material: Silicone rubber or FPM
- Maximum operating temperature: 135°C
- Watertightness: IP68 according to IEC 60529 for K series

BFG Plug caps with key (G)

Part number	Series	Dimensions (mm)			
		A	B	L	N
BFG.0K.100.NAS	0K	14.0	6	12.5	85
BFG.2K.100.NAS	2K	19.5	6	17.5	85
BFG.3K.100.NAS	3K	23.0	6	22.0	120
BFG.4B.100.NAS	4B	25.0	10	20.2	120
BFG.4K.100.NAS	4K	29.0	10	22.5	120
BFG.5B.100.NAS	5B	36.0	10	27.2	150
BFG.5K.100.NAS	5K	44.0	10	27.0	150

Note: This cap is available only with an alignment key (G). The last letter «S» of the part number stands for the material of the O-ring (silicone rubber). O-rings made from FPM are also available; if required, replace the letter «S» by «V».

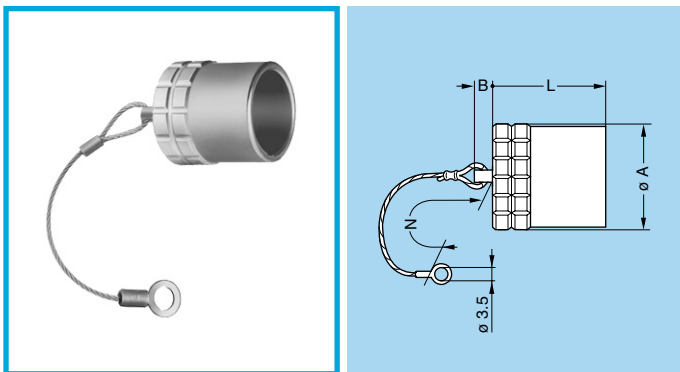

- Body material: Nickel-plated brass (Ni 3µm)
- Lanyard material: Stainless steel
- Crimp ferrule material: Nickel-plated brass + polyolefin
- O-ring material: Silicone rubber or FPM
- Maximum operating temperature: 135°C
- Watertightness: IP68 according to IEC 60529 for K series

BHG Plug caps, nut fixing or flange

Part number	Series	Dimensions (mm)			
		A	B	L	N
BHG.0K.100.NAS	0K	14.0	6	12.5	85
BHG.2K.100.NAS	2K	19.5	6	17.5	85
BHG.3K.100.NAS	3K	23.0	6	22.0	120
BHG.4B.100.NAS	4B	25.0	10	20.2	120
BHG.4K.100.NAS	4K	29.0	10	22.5	120
BHG.5B.100.NAS	5B	36.0	10	27.2	150
BHG.5K.100.NAS	5K	44.0	10	27.0	150

Note: This cap is available only with an alignment key (G). The last letter «S» of the part number stands for the material of the O-ring (silicone rubber). O-rings made from FPM are also available; if required, replace the letter «S» by «V».

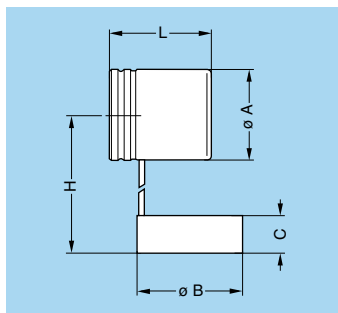

BFA Plug cap

Part number	Series	Dimensions (mm)				
		A	B	C	H	L
BFA.3K.170.800EN	3K	24	28	10	80	27

- Material: black EPDM

Note: These caps are suitable for use with any alignment key configuration.

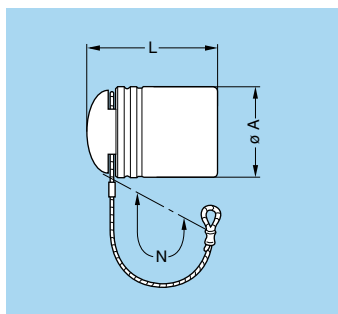

BFG Plug cap

Part number	Series	Dimensions (mm)		
		A	L	N
BFG.3K.100.EAN	3K	24	30	155

- Material: black EPDM
- Lanyard material: Stainless steel
- Crimp ferrule material: Nickel-plated brass + polyolefin

Note: These caps are suitable for use with any alignment key configuration.

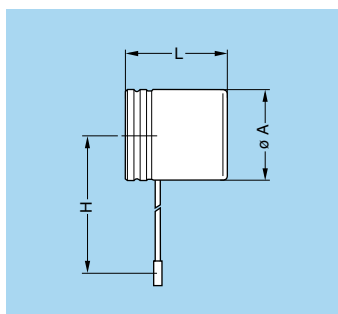

BHA Plug cap

Part number	Series	Dimensions (mm)		
		A	H	L
BHA.3K.100.715EN	3K	24	80	27

- Material: black EPDM

Note: These caps are suitable for use with any alignment key configuration.

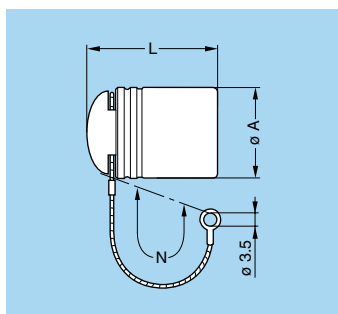

BHA Plug cap

Part number	Series	Dimensions (mm)		
		A	L	N
BHA.3K.100.EAN	3K	24	30	120

- Material: black EPDM
- Lanyard material: Stainless steel
- Crimp ferrule material: Nickel-plated brass + polyolefin

Note: These caps are suitable for use with any alignment key configuration.

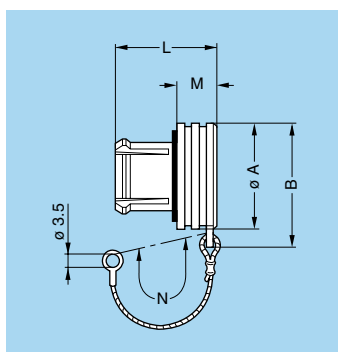

BRA Blanking caps for fixed sockets and free straight sockets

Part number	Series	Dimensions (mm)				
		A	B	L	M	N
BRA.00.200.PCSG	00	7.5	9.8	9.0	3.5	60
BRA.0B.200.PCSG	0B	10.0	12.5	11.0	4.8	60
BRA.2B.200.PCSG	2B	18.0	21.0	14.5	6.0	60
BRA.3B.200.PCSG	3B	22.0	25.5	17.0	7.0	60

Note: These caps are suitable for use with any alignment key configuration. On request this cap can be supplied in black. If so, replace the last letter «G» of the part number by «N».

- Body material: Polyoxymethylene (POM) grey (or black)
- Cord material: Polyamide 6, grey (or black)
- Crimp ferrule material: Nickel-plated brass
- Gasket material: Silicone rubber
- Maximum operating temperature: 100°C
- Watertightness: IP61 according to IEC 60529

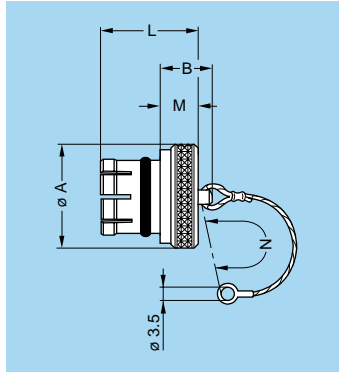

- Body material: Nickel-plated brass (Ni 3 μm)
- Lanyard material: Stainless steel
- Crimp ferrule material: Nickel-plated brass + polyolefin
- O-ring material: Silicone rubber or FPM
- Maximum operating temperature: 135°C

BRE Blanking caps for fixed and free sockets

Part number	Series	Dimensions (mm)				
		A	B	L	M	N
BRE.00.200.NAS	00	8	9.5	8.8	3.5	60
BRE.0S.200.NAS	0B	10	10.5	10.5	4.5	85
BRE.2S.200.NAS	2B	18	12.0	14.0	6.0	85
BRE.3S.200.NAS	3B	22	14.0	18.0	8.0	120
BRE.4S.200.NAS	4B	28	20.0	23.0	10.0	120
BRE.5S.200.NAS	5B	40	22.0	30.0	12.0	150

Note: These caps are suitable for use with any alignment key configuration. The last letter «S» of the part number stands for the O-ring material (silicone rubber). O-rings made from FPM are also available; if required, replace the letter «S» by «V».

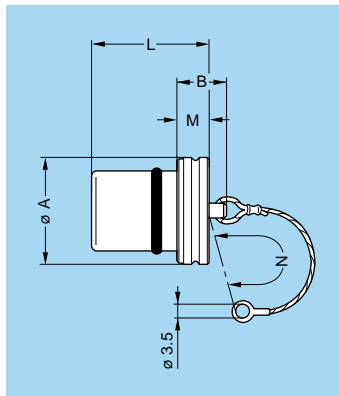

- Body material: Nickel-plated brass (Ni 3 μm)
- Lanyard material: Stainless steel
- Crimp ferrule material: Nickel-plated brass + polyolefines
- O-ring material: Silicone rubber or FPM
- Maximum operating temperature: 135°C
- Watertightness: IP68 according to IEC 60529

BRE Blanking caps for fixed and free sockets

Part number	Series	Dimensions (mm)				
		A	B	L	M	N
BRE.0K.200.NAS	0K	15.0	10	15.0	4	85
BRE.2K.200.NAS	2K	20.5	14	24.0	8	85
BRE.3K.200.NAS	3K	24.0	14	28.0	8	120
BRE.4K.200.NAS	4K	30.0	20	30.5	10	120
BRE.5K.200.NAS	5K	44.0	22	37.0	12	150

Note: These caps are suitable for use with any alignment key configuration. The last letter «S» of the part number stands for the O-ring material (silicone rubber). O-rings made from FPM are also available; if required, replace the letter «S» by «V».

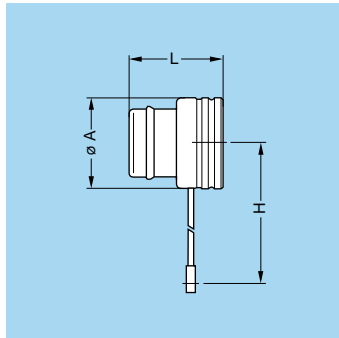

BRA Blanking cap for free sockets

Part number	Series	Dimensions (mm)		
		A	H	L
BRA.3K.100.715EN	3K	24	80	25

- Material: black EPDM

Note: These caps are suitable for use with any alignment key configuration.

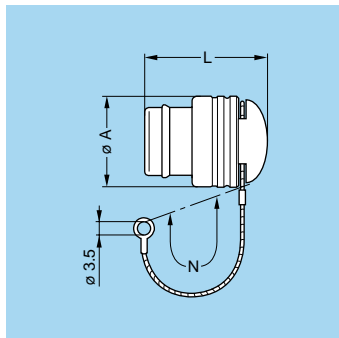

BRA Blanking cap for free sockets

Part number	Series	Dimensions (mm)		
		A	L	N
BRA.3K.200.EAN	3K	24	26	120

- Material: black EPDM
- Lanyard material: Stainless steel
- Crimp ferrule material: Nickel-plated brass + polyolefin

Note: These caps are suitable for use with any alignment key configuration.

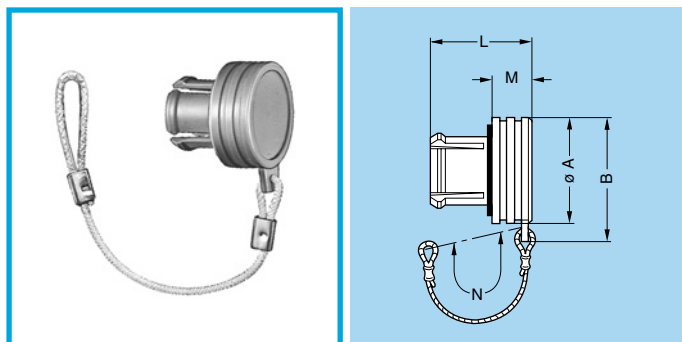

- Body material: Polyoxymethylene (POM) grey (or black)
- Cord material: Polyamide 6, grey (or black)
- Crimp ferrule material: Nickel-plated brass
- Gasket material: Silicone rubber
- Maximum operating temperature: 100°C
- Watertightness: IP61 according to IEC 60529

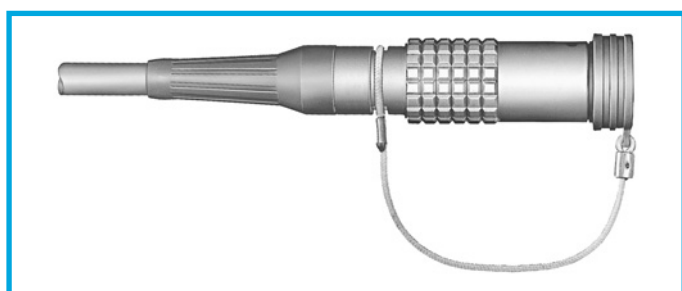

BRD Blanking caps for free sockets

Part number	Series	Dimensions (mm)				
		A	B	L	M	N
BRD.00.200.PCSG	00	7.5	9.8	9.0	3.5	85
BRD.0B.200.PCSG	0B	10.0	12.5	11.0	4.8	85
BRD.2B.200.PCSG	2B	18.0	21.0	14.5	6.0	85
BRD.3B.200.PCSG	3B	22.0	25.5	17.0	7.0	95

Note: On request this cap is available in black. If required, replace the last letter «G» of the part number by «N».

Fitting the cord

Slide the socket into the loop of the cord.
Place the loop into the groove in front of the collet nut.
Tighten the loop.

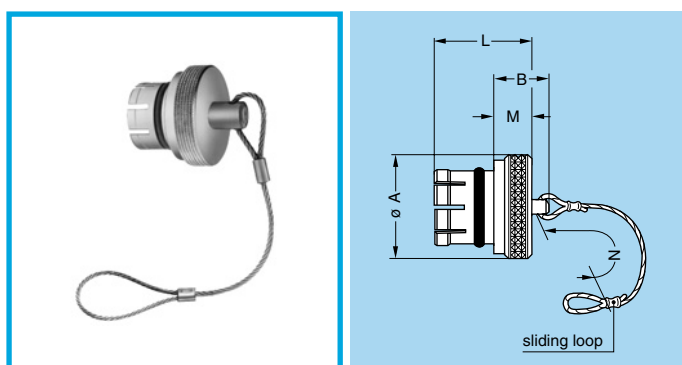

- Body material: Nickel-plated brass (Ni 3 µm)
- Lanyard material: Stainless steel
- Crimp ferrule material: Nickel-plated brass + polyolefin
- O-ring material: Silicone rubber or FPM
- Maximum operating temperature: 135°C

BRF Blanking caps for free sockets

Part number	Series	Dimensions (mm)				
		A	B	L	M	N
BRF.00.200.NAS	00	8	7.5	8.8	3.5	85
BRF.0S.200.NAS	0B	10	9.5	10.5	4.5	85
BRF.2S.200.NAS	2B	18	12.0	14.0	6.0	85
BRF.3S.200.NAS	3B	22	14.0	18.0	8.0	120
BRF.4S.200.NAS	4B	28	20.0	23.0	10.0	120
BRF.5S.200.NAS	5B	40	22.0	30.0	12.0	150

Note: These caps are suitable for use with any alignment key configuration. The last letter «S» of the part number stands for the O-ring material (silicone rubber). O-rings made from FPM are also available; if required, replace the letter «S» by «V».

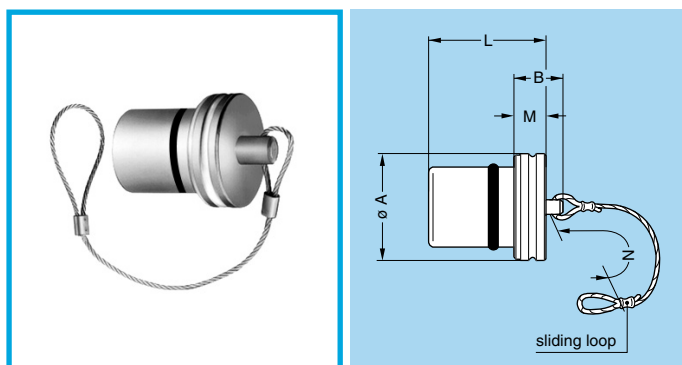

- Body material: Nickel-plated brass (Ni 3 µm)
- Lanyard material: Stainless steel
- Crimp ferrule material: Nickel-plated brass + polyolefin
- O-ring material: Silicone rubber or FPM

BRF Blanking caps for free sockets

Part number	Series	Dimensions (mm)				
		A	B	L	M	N
BRF.0K.200.NAS	0K	15.0	10	15.0	4	85
BRF.2K.200.NAS	2K	20.5	14	24.0	8	85
BRF.3K.200.NAS	3K	24.0	14	28.0	8	120
BRF.4K.200.NAS	4K	30.0	20	30.5	10	120
BRF.5K.200.NAS	5K	44.0	22	37.0	12	150

Note: These caps are suitable for use with any alignment key configuration. The last letter «S» of the part number stands for the O-ring material (silicone rubber). O-rings made from FPM are also available; if required, replace the letter «S» by «V».

- Maximum operating temperature: 135°C
- Watertightness: IP68 according to IEC 60529

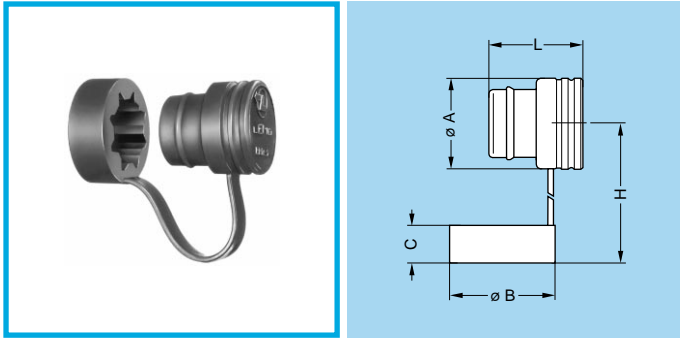

BRD Blanking caps for free sockets

Part number	Series	Dimensions (mm)				
		A	B	C	H	L
BRD.3K.170.800EN	3K	24	28	10	80	25

- Material: black EPDM

Note: These caps are suitable for use with any alignment key configuration.

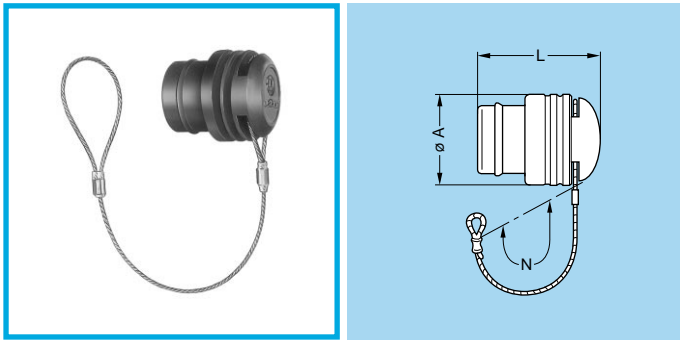

BRF Blanking caps for free sockets

Part number	Series	Dimensions (mm)		
		A	L	N
BRF.3K.200.EAN	3K	24	26	155

- Material: black EPDM
- Lanyard material: Stainless steel
- Crimp ferrule material: Nickel-plated brass + polyolefin

Note: These caps are suitable for use with any alignment key configuration.

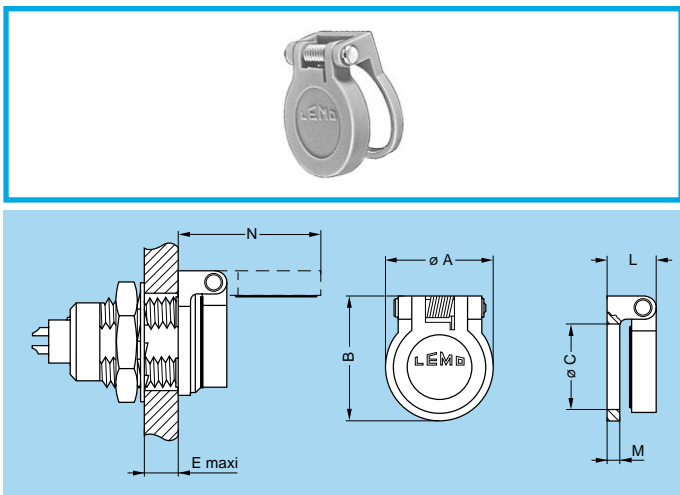

BRR Spring loaded dust caps for ERA, ERN and EG● sockets or PSA and PK● fixed sockets

Part number	Series	Dimensions (mm)						
		A	B	C	E	L	M	N
BRR.0S.200.PZSG	0B	11.0	13.3	9.0	5.8	5.0	1.2	15.3
BRR.2S.200.PZSG	2B	18.6	22.4	15.2	6.5	8.2	2.0	26.2
BRR.3S.200.PZSG	3B	22.5	26.5	18.2	9.0	8.8	2.5	30.8

Note: On request, this cap is available in black. If so replace the last letter «G» of the part number by «N».

- Body material: Polyoxymethylene (POM) grey (or black)
- Gasket material: Silicone rubber
- Spring material: Stainless steel
- Axes material: Nickel-plated brass
- Maximum operating temperature: 100°C
- Watertightness: IP61 according to IEC 60529

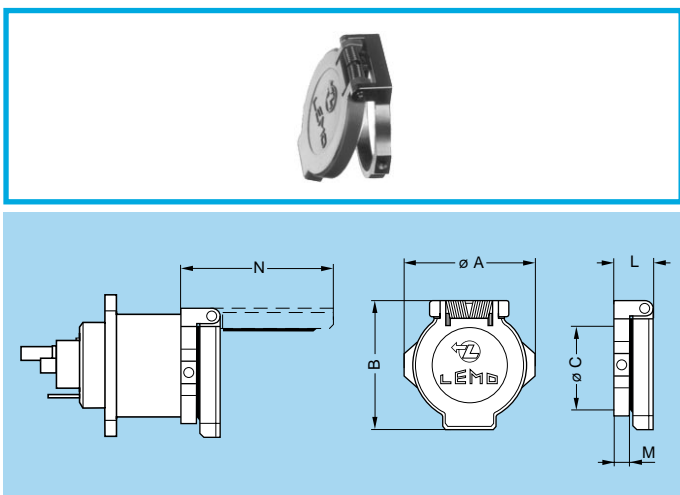

BRR Spring loaded dust cap for ED● and EB● fixed sockets

Part number	Series	Dimensions (mm)					
		A	B	C	L	M	N
BRR.3K.200.PZSG	3K	29	29	23	8.1	3	33.2

Note: On request, this cap is available in black. If so replace the last letter «G» of the part number by «N».

- Cap material: Polyoxymethylene (POM) grey (or black)
- Body material: Nickel-plated brass
- Gasket material: Silicone rubber
- Spring material: Stainless steel
- Axes material: Nickel-plated brass
- Maximum operating temperature: 100°C
- Watertightness: IP61 according to IEC 60529

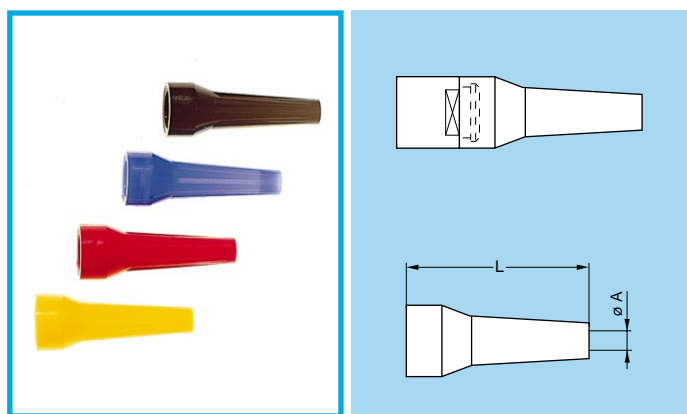

GM• Bend reliefs (Polyurethane)

A bend relief made from thermoplastic polyurethane elastomer (Desmopan 786) can be fitted over LEMO plugs and sockets that are supplied with a specially fitted nut. These are available in nine different colours that match with the GRA insulating washers (see page 93).

Use the part numbers shown below to order this accessory separately.

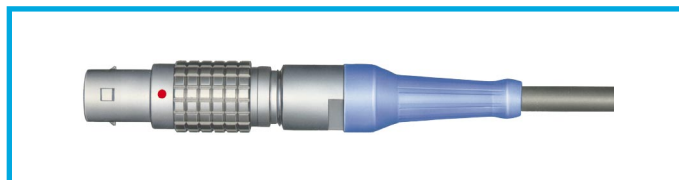

Main characteristics

- Material: Polyurethane elastomer
- Temperature range in dry atmosphere: -40°C to +80°C

Part number	Dimensions (mm)				Series	Part number of nut for fitting the bend relief
	Bend relief		Cable ø			
	A	L	max.	min.		
GMA.00.012.DG	1.2	22	1.4	1.1	00	FFM.00.131.LC
GMA.00.018.DG	1.8	22	2.1	1.8		
GMD.00.025.DG	2.5	22	2.8	2.5		
GMD.00.028.DG	2.8	22	3.1	2.8		
GMD.00.032.DG	3.2	22	3.5	3.2		
GMA.0B.025.DG	2.5	24	2.9	2.5	0B	FFM.0B.130.LC
GMA.0B.030.DG	3.0	24	3.4	3.0	2B	FFM.2B.132.LC ¹⁾
GMA.0B.035.DG	3.5	24	3.9	3.5		
GMA.0B.040.DG	4.0	24	4.4	4.0	0K	FFM.0E.130.LC
GMA.0B.045.DG	4.5	24	5.2	4.5		
GMA.1B.040.DG	4.0	30	4.4	4.0	3B	FFM.3B.131.LC ²⁾
GMA.1B.045.DG	4.5	30	4.9	4.5		
GMA.1B.054.DG	5.4	30	6.0	5.4		
GMA.2B.040.DG	4.0	36	4.5	4.0	2B	FFM.2B.130.LC
GMA.2B.045.DG	4.5	36	5.0	4.5	4B	FFM.4B.132.LC ³⁾
GMA.2B.050.DG	5.0	36	5.5	5.0	2K	FFM.2E.130.LC
GMA.2B.060.DG	6.0	36	6.5	6.0	3K	FFM.3K.133.LC
GMA.2B.070.DG	7.0	36	7.7	7.0	4K	FFM.4K.132.LC
GMA.2B.080.DG	7.8	36	8.8	7.8	5K	FFM.5K.132.LC
GMA.3B.050.DG	4.5	42	5.2	4.5	3B	FFM.3B.130.LC
GMA.3B.060.DG	6.0	42	6.9	6.0		
GMA.3B.070.DG	7.0	42	7.9	7.0	3K	FFM.3E.130.LC
GMA.3B.080.DG	8.0	42	8.9	8.0	4K	FFM.4K.133.LC
GMA.3B.090.DG	9.0	42	10.0	9.0	5K	FFM.5K.131.LC
GMA.4B.080.DG	8.0	60	9.0	8.0	4B	FFM.4B.130.LC
GMA.4B.010.DG	10.0	60	10.9	10.0		
GMA.4B.011.DG	11.0	60	11.9	11.0	4K	FFM.3K.132.LC
GMA.4B.012.DG	12.0	60	13.0	12.0	5K	FFM.5K.133.LC
GMA.4B.013.DG	13.5	60	14.5	13.5		

Note: The last letter «G» of the part number indicates the grey colour of the bend relief. For ordering a bend relief with another colour, see table on page 92 and replace the letter «G» by the letter of the required colour.

See also detailed information for each series: B series on page 61; K series on page 61.

¹⁾ For use only with connectors from series 2B equipped with cable fixing type M and where a bend relief from series 0B is used.

²⁾ For use only with connectors from series 3B equipped with cable fixing type M and where a bend relief from series 1B is used.

³⁾ For use only with connectors from series 4B equipped with cable fixing type M and where a bend relief from series 2B is used.

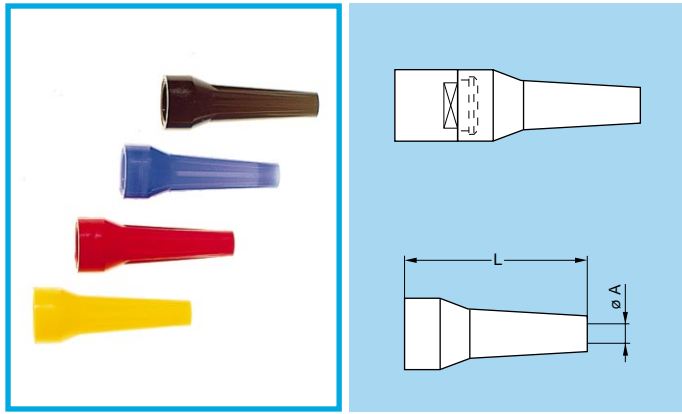

GM Bend reliefs (Silicone)

A bend relief has been designed for connectors used in applications at high temperature or requiring vapor sterilization.

These bend reliefs are different from previous ones; their material, a silicone elastomer, is noted for its retention of flexibility over a wide temperature range. They are available in nine colours.

Use the part numbers shown below to order this accessory separately.

Main characteristics

- Material: Silicone elastomer VMQ
- Temperature range in dry atmosphere: -60°C to +200°C
- Temperature range in water steam: +140°C
- Inflammability: not flammable (no UL classification)

Part number	Dimensions (mm)				Series	Part number of nut for fitting the bend relief
	Bend relief		Cable ø			
	A	L	max.	min.		
GMA.0B.025.RG	2.5	27	2.9	2.5	0B	FFM.0B.130.LC
GMA.0B.030.RG	3.0	27	3.4	3.0		
GMA.0B.035.RG	3.5	27	3.9	3.5	2B	FFM.2B.132.LC ¹⁾
GMA.0B.040.RG	4.0	27	4.4	4.0		
GMA.0B.045.RG	4.5	27	5.2	4.5	0K	FFM.0E.130.LC
GMA.1B.040.RG	4.0	34	4.4	4.0	3B	FFM.3B.131.LC ²⁾
GMA.1B.045.RG	4.5	34	5.0	4.5		
GMA.2B.040.RG	4.0	41	4.4	4.0	2B	FFM.2B.130.LC
GMA.2B.045.RG	4.5	41	5.0	4.5	4B	FFM.4B.132.LC ³⁾
GMA.2B.051.RG	5.1	41	5.6	5.1		
GMA.2B.057.RG	5.7	41	6.2	5.7	2K	FFM.2E.130.LC
GMA.2B.063.RG	6.3	41	7.0	6.3	3K	FFM.3K.133.LC
GMA.2B.071.RG	7.1	41	7.9	7.1	4K	FFM.4K.132.LC
GMA.2B.080.RG	8.0	41	9.0	8.0	5K	FFM.5K.132.LC

Note: The last letter «G» of the part number indicates the grey colour of the bend relief. For ordering a bend relief with another colour, see table on page 92 and replace the letter «G» by the letter of the required colour.

See also detailed information for each series: B series on page 61; K series on page 61.

¹⁾ For use only with connectors from series 2B equipped with cable fixing type M and where a bend relief from series 0B is used.

²⁾ For use only with connectors from series 3B equipped with cable fixing type M and where a bend relief from series 1B is used.

³⁾ For use only with connectors from series 4B equipped with cable fixing type M and where a bend relief from series 2B is used.

Note: The selection of pigments, which should remain stable at high temperature, is limited by new regulations. For this reason, some colours will be a shade different from those used for Desmopan bend reliefs. The selected solutions represent the best possible compromise.

Ref.	Colour	Ref.	Colour
A	blue	N	black
B	white	R	red
G	grey	S	orange
J	yellow	V	green
M	brown		

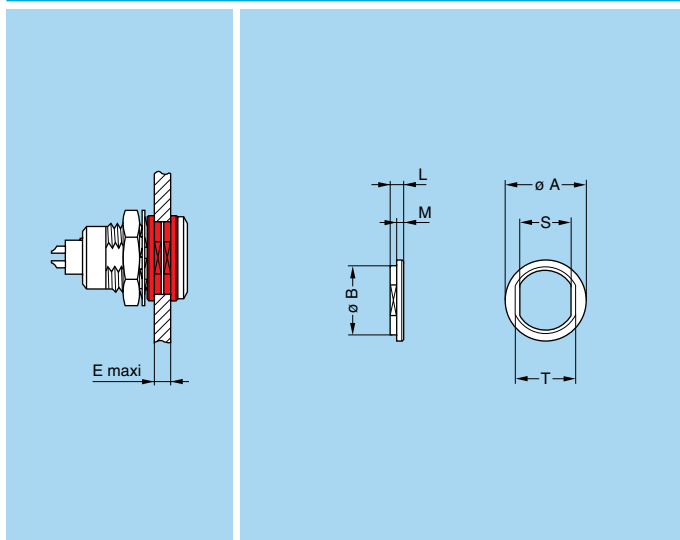

- Material: Polyamide
- Maximum operating temperature: 90°C

GRA Insulating washers

Sockets or plugs mounted on panels can be fitted with insulating washers. The nine colours available combined with those for the overall protective coverings with bend relief makes colour coding possible.

Part number	Series	Dimensions (mm)						
		A	B	E	L	M	S	T
GRA.00.269.GG	00	10.0	8.8	4.5	1.8	1.0	6.4	8.0
GRA.0S.269.GG	0B	12.0	10.8	6.0	1.8	1.0	8.3	9.9
GRA.2S.269.GG	2B	21.1	17.9	7.3	2.3	1.3	13.6	16.2
GRA.3S.269.GG	3B	25.0	21.8	10.3	2.2	1.2	16.7	20.2
GRA.4S.269.GG	4B	31.9	28.7	10.5	2.5	1.5	23.6	27.1

Note: Insulating washers for series 5B are available on request.

Caution: These insulating washers can be used with fixed and straight sockets with across flat dimension S1 equivalent to the S dimension of the washer.

Ref.	Colour	Ref.	Colour
A	blue	N	black
B	white	R	red
G	grey	S	orange
J	yellow	V	green
M	brown		

Note: The last letter «G» of the part number indicates the colour grey for the insulating washer. To obtain an insulating washer of another colour, refer to the table above and change the letter «G» of the part number to the corresponding letter of the colour required.

For the panel cut-out, please consult chapter «Panel cut-out» on pages 18, 26 and 45.

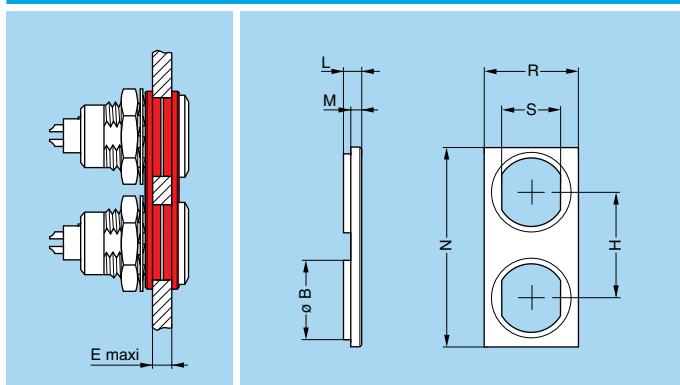

- Material: Polyamide
- Maximum operating temperature: 90°C

GRC Double panel washers

Double panel washers have been designed to make the drilling of panel holes easier for mounting fixed and straight sockets. The combination of the nine different colours of the double panel washers and of the overall protective coverings with bend relief makes colour coding possible.

Part number	Series	Dimensions (mm)							
		B	E	H	L	M	N	R	S
GRC.0S.260.HG	0B	10.9	5	14	2.5	1.5	26.5	12.5	8.3

Caution: These double panel washers can be used with fixed or free sockets with across flat dimension S1 equivalent to the S dimension of the washer.

Ref.	Colour	Ref.	Colour
A	blue	N	black
B	white	R	red
G	grey	S	orange
J	yellow	V	green
M	brown		

Note: The last letter «G» of the washer's part number indicates the colour grey. For other colours, refer to the above table and replace letter «G» by the one corresponding to the colour required.

For the panel cut-out, please consult chapter «Panel cut-out» on page 26.

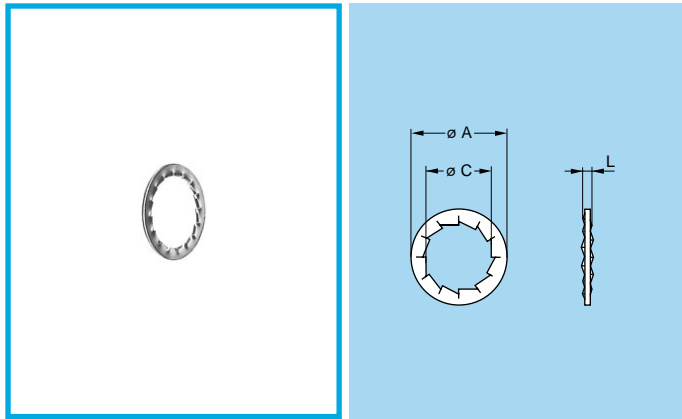

- Material: Nickel-plated bronze (3 μm)

GBA Locking washers

Part number	Series	Dimensions (mm)		
		A	C	L
GBA.00.250.FN	00	9.5	7.1	1.0
GBA.0S.250.FN	0B	12.5	9.1	1.0
GBA.2S.250.FN	2B	19.5	15.1	1.2
GBA.3S.250.FN	3B	25.0	18.1	1.4
GBA.4S.250.FN	4B	32.0	25.1	1.4

Note: To order this accessory separately, use the above part numbers.

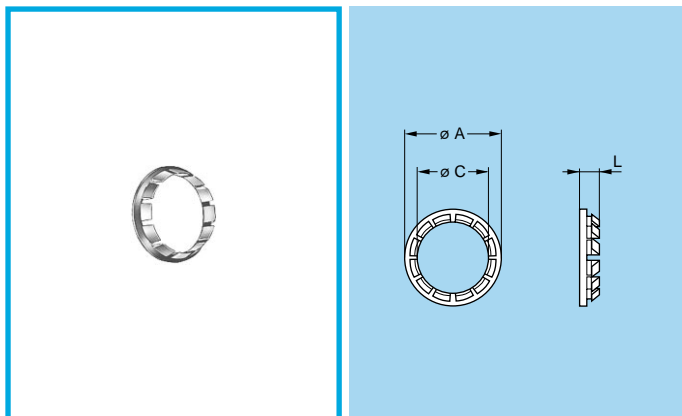

- Material: Nickel-plated brass (3 μm)

GBB Tapered washers

Part number	Series	Dimensions (mm)		
		A	C	L
GBB.00.250.LN	00	9	7.1	2.0
GBB.0S.250.LN	0B	11	9.1	2.5
GBB.2S.250.LN	2B	18	15.1	4.0
GBB.3S.250.LN	3B	22	18.1	4.5
GBB.4S.250.LN	4B	28	25.2	5.0
GBB.5S.250.LN	5B	40	35.2	7.5

Note: Sockets of series 5B are always supplied with a tapered washer. To order this accessory separately, use the above part numbers.

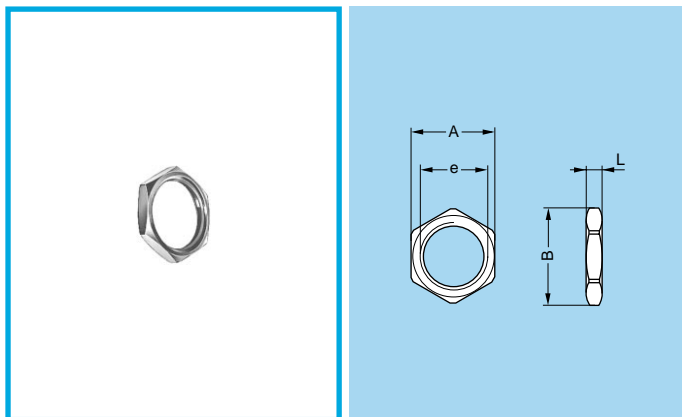

- Material:
 - Nickel-plated brass (3 μm)
 - Natural anodized aluminium alloy
 - Stainless steel

GEA Hexagonal nuts

Part number	Series	Dimensions (mm)			
		A	B	e	L
GEA.00.240.LN	00	9	10.2	M7 x 0.50	2.0
GEA.0S.240.LN	0B	11	12.4	M9 x 0.60	2.0
GEA.0E.240.LN	0K	17	19.2	M14 x 1.00	2.5
GEA.2S.240.LN	2B	17	19.2	M15 x 1.00	2.7
GEA.2E.240.LN	2K	24	27.0	M20 x 1.00	4.0
GEA.3S.240.LN	3B	22	25.0	M18 x 1.00	3.0
GEA.3E.240.LN	3K	30	34.0	M24 x 1.00	5.0
GEA.4S.240.LN	4B	30	34.0	M25 x 1.00	5.0
GEA.4E.240.LN	4K	36	40.5	M30 x 1.00	7.0

Note: To order this part separately, use the above part numbers. The last letters «LN» of the part number refer to the nut material and treatment. If a nut in aluminium alloy or stainless steel is desired, replace the last letters of the part number by «PT» or «AZ» respectively.

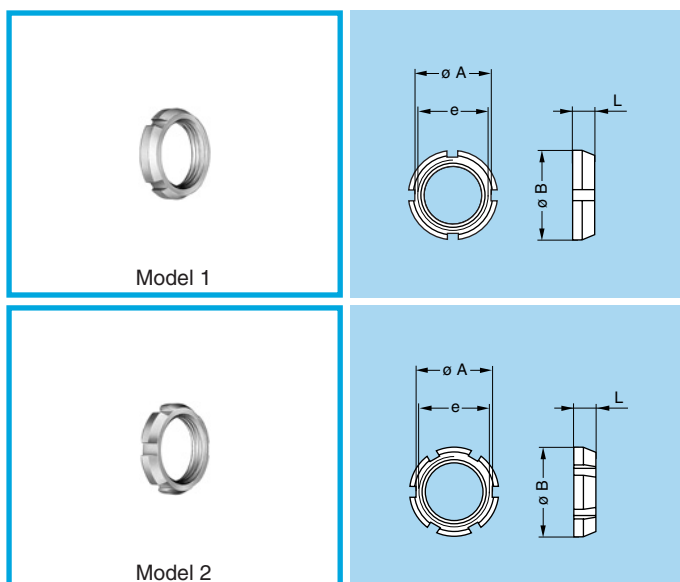

GEG Notched nuts

Part number	Series	Model	Dimensions (mm)			
			A	B	e	L
GEG.00.240.LC	00	1	8.7	10	M7 x 0.5	2.5
GEG.0S.240.LC	0B	1	10.5	12	M9 x 0.6	2.5
GEG.0E.240.LC	0K	1	15.8	18	M14 x 1.0	3.5
GEG.2S.240.LC	2B	2	17.5	20	M15 x 1.0	3.5
GEG.2E.240.LC	2K	2	22.5	25	M20 x 1.0	3.5

● Material: Chrome-plated brass (Ni 3 μm + Cr 0.3 μm)

Note: 00, 0B and 2B series fixed and free sockets for back panel mounting are always delivered with this notched nut. To order this accessory separately, use the above part numbers.

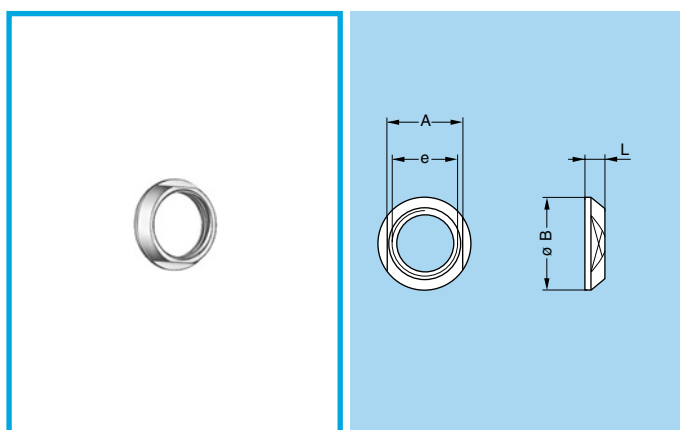

GEC Conical nuts

Part number	Series	Dimensions (mm)				
		A	B	e	L	S1
GEC.00.240.LC	00	8	10.0	M7 x 0.5	2.5	8
GEC.0S.240.LC	0B	10	12.0	M9 x 0.6	2.5	10
GEC.0E.240.LC	0K	16	18.0	M14 x 1.0	3.0	16
GEC.2S.240.LC	2B	17	20.0	M15 x 1.0	3.8	17
GEC.2E.240.LC	2K	22	25.0	M20 x 1.0	5.0	22
GEC.3S.240.LC	3B	20	24.0	M18 x 1.0	4.5	20
GEC.3E.240.LC	3K	27	30.0	M24 x 1.0	4.5	27
GEC.4S.240.LC	4B	27	30.0	M25 x 1.0	4.5	27
GEC.4K.241.LC	4K	32	35.5	M30 x 1.0	5.0	32
GEC.5S.240.LC	5B	37	41.0	M35 x 1.0	5.0	37

● Material: Chrome-plated brass (Ni 3 μm + Cr 0.3 μm)

Note: 3B, 3K, 4B, 4K, 5B and 5K series fixed and free sockets for back panel mounting are always delivered with a conical nut. To order this accessory separately, use the part numbers in the table above.

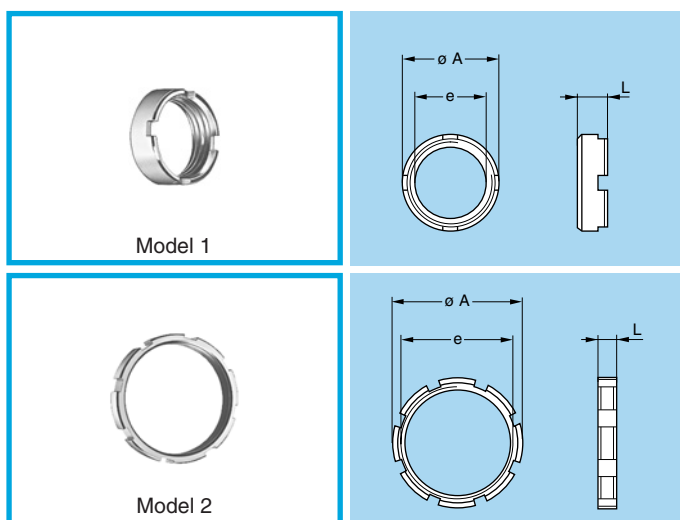

GEB Round nuts

Part number	Series	Model	Dimensions (mm)		
			A	e	L
GEB.00.240.LN	00	1	9.0	M7 x 0.50	4.0
GEB.0S.240.LN	0B	1	11.0	M9 x 0.60	4.0
GEB.2S.240.LN	2B	1	18.0	M15 x 1.00	5.5
GEB.3S.240.LN	3B	1	22.0	M18 x 1.00	5.5
GEB.4S.240.LN	4B	1	28.0	M25 x 1.00	6.0
GEB.5S.240.LN	5B	2	40.0	M35 x 1.00	8.0
GEB.5E.240.LN	5K	2	54.0	M45 x 1.50	8.0

● Material: Nickel-plated brass (3 μm)

Note: 5B and 5K series sockets are always supplied with model 2 round nuts. To order this accessory separately, use the part numbers in the table above.

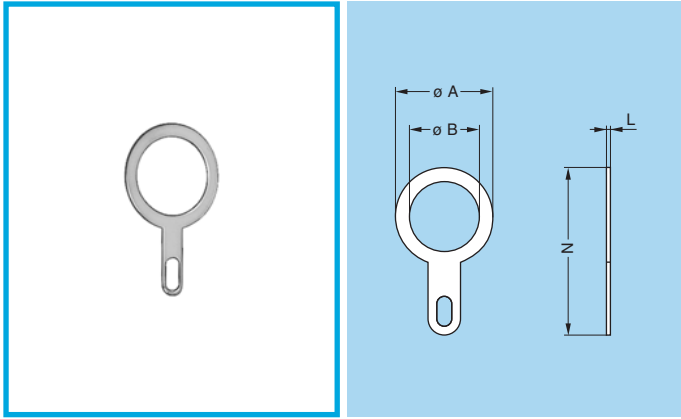

GCA Earthing washers

Part number	Series	Dimensions (mm)			
		A	B	L	N
GCA.00.255.LT	00	9.5	7.1	0.4	18.2
GCA.0S.255.LT	0B	13.0	9.1	0.4	22.0
GCA.0E.255.LT	0K	17.0	14.1	0.5	27.5
GCA.2S.255.LT	2B	20.0	15.2	0.5	32.0
GCA.2E.255.LT	2K	25.0	20.2	0.5	39.0
GCA.3S.255.LT	3B	25.0	18.2	0.5	39.0
GCA.4S.255.LT	4B	35.0	25.6	0.6	50.0
GCA.4E.255.LT	4K	35.0	30.6	0.6	50.0
GCA.5S.255.LT	5B	42.0	35.1	0.3	57.5

- Material: CuSnZn plated brass (2 µm)