

StageSource L3t

The World's Most Versatile Loudspeaker System for Musicians



Technical Specifications



StageSource™ L3t Technical Specifications

StageSource L3t combines multi-function design, powerful DSP and precision components to deliver the perfect blend of high-powered performance and true scalability. With Smart Speaker modes, an integrated mixer and digital networking, StageSource L3t delivers best-of-class performance across the widest variety of live sound applications.

- 1,400-watt, 3-way, tri-amped speaker system
- Smart Speaker Modes for great live sound in any live sound situation
- Multi-channel mixer with 3-band EQ, Smart Effects, and acoustic guitar modeling
- Multi-band feedback suppression
- On-board accelerometer and pole-mount sensors
- Virtual Tilt-back projects speaker's output upwards in backline mode
- L6 LINK™ digital networking for multi-speaker setups
- Multi-function design for true scalability
- Dual-braced tour-grade plywood enclosure with M10 suspension points
- Retractable handles for easy portability

Acoustical

System Type:	Dual 10", 3-way, tri-amplified loudspeaker system
Frequency Range (-10 dB):	40 Hz to 19 kHz, (Reference/P.A. Speaker Mode, free-field)
Frequency Response (±3 dB):	47 Hz to 18 kHz, (Reference/P.A. Speaker Mode, free-field)
Maximum SPL Output:	132 dB peak @ 1 meter (unweighted, measured indoors with music program material)
Coverage Pattern (-6 dB):	100° horizontal x 50° vertical
Directivity Factor (Q):	8.7 (averaged 1 kHz to 16 kHz)
Directivity Index (DI):	9.4 dB (averaged 1 kHz to 16 kHz)
Crossover Frequencies:	LF1 Low-pass - 250 Hz LF2 to HF Crossover - variable, 2.2 kHz to 7.0 kHz (Speaker Mode dependent)
Low Frequency Transducers:	2 x 10" extended range woofer, 2" diameter voice coil, 4Ω impedance
High Frequency Transducer:	1" exit compression driver, 1.4" diameter voice coil and diaphragm, 8Ω impedance

Electrical – Side Panel

Input Type:	2x mic/instrument XLR-1/4", balanced
Input Impedance (each input):	2.63 kΩ balanced (Pad = 0 dB), 23.7 kΩ balanced (Pad = 20 dB)
Gain Range (each input):	-infinity to +57 dB (Pad = 0 dB); -infinity to +37 dB (Pad = 20 dB)
Max Input Level:	+25 dBu (Gain at minimum 'on' position, 20 dB pad on)
Controls:	2x Gain, 20 dB Pad, LF Level, MF Freq & Level, HF Level, Mod Level, Reverb Level, Feedback Suppression On/Off/Mode 1x Dual Mono/Stereo Link Mode, Acoustic Modeling Amount, On/Off
Indicators:	2x Signal Present/Clip, 2x Feedback Suppression On/Off/Mode, 1x Acoustic Modeling On/Off

StageSource L3t

The World's Most Versatile Loudspeaker System for Musicians



Technical Specifications

Electrical – Rear Panel

Input Types:	Line-level XLR-1/4", balanced	Stereo RCA, unbalanced	L6 LINK™ XLR
Input Impedance:	100 kΩ balanced	20 kΩ balanced	N/A
Max Input Levels:	+20 dBu	+16 Dbv	N/A
Onset of Limiting:	+7 dBu input (Reference/P.A. Speaker Mode, Master Level control at center-detent) -5 dBu input (Reference/P.A. Speaker Mode, Master Level control at maximum)		
Output Types:	Balanced Loop Thru XLR	Balanced Mix Out XLR	L6 LINK XLR
Output Impedances:	Source-dependent	680 Ω balanced	N/A
Controls:	Feedback Suppression On/Off/Mode, Master Level, Speaker Mode		
Indicators:	Signal Present/Clip, Feedback Suppression On/Off/Mode, Limit, 6x Speaker Mode, L6 LINK Status		

Digital Signal Processing

Speaker Modes:	Reference/P.A., Playback, Floor Monitor, Keyboards, Acoustic Guitar, Electric Guitar
On-board Effects:	Reverb, Modulation, Feedback Suppression, Acoustic Modeling
Transducer Protection:	Excursion limiting, thermal limiting
Digital Networking:	L6 LINK Intelligent Speaker Networking System
Sensors:	Speaker orientation, pole sensor, power amp temperature, power supply, temperature

Power Amplification and Supply

Output Channel:	LF1	LF2	HF
Power Amplifier Type:	Class D	Class D	Class AB
Peak Output Power ¹ :	655 Watts	655 Watts	175 Watts
Power Supply Voltage Range:	100 - 240 VAC, ± 10%, 50/60 Hz , automatic voltage selection		
Power Consumption:	250 watts (1/8th power)		
Cooling:	Digitally-controlled, variable speed 50 mm fan		
Protection:	Output overcurrent, overtemperature, DC fault		

Mechanical

Enclosure:	15 mm enclosure, 18 mm baffle, multi-ply hardwood, textured black paint, bass reflex design
Floor Monitor Upward Angle:	60° using kickstands, 30° using handle
Suspension Points:	M10 x 1.5 threaded inserts, qty: 4
Pullback Point:	M10 x 1.5 threaded insert, qty: 1
Grille:	18 gauge perforated steel, black powder coat finish
Pole Cup:	35 mm pole cup with sensor
Dimensions (HxWxD):	33.875" (861 mm) x 12.25" (312 mm) x 12.25" (312 mm)
Weight:	57.5 lb (26.1 kg)

Accessory Part Numbers

Speaker Bag:	98-037-0001
Short Pole:	98-037-0003
Long Pole:	98-037-0004
Eyebolt Suspension Kit:	98-037-0005

¹ 1kHz sine wave input, 1% THD+N unweighted into the nominal load impedance, single channel driven, before the onset of limiting.

StageSource L3t

The World's Most Versatile Loudspeaker System for Musicians



Technical Specifications

Mixer Control Panel

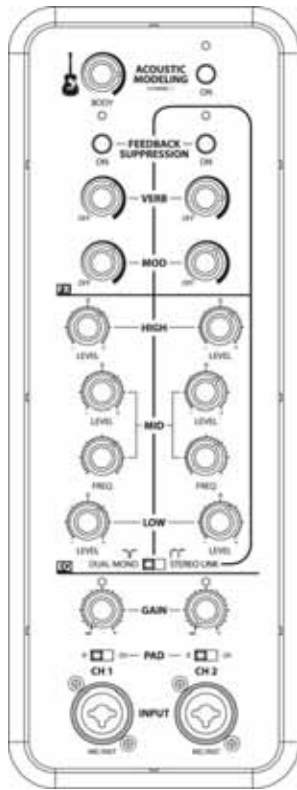

System Control Panel

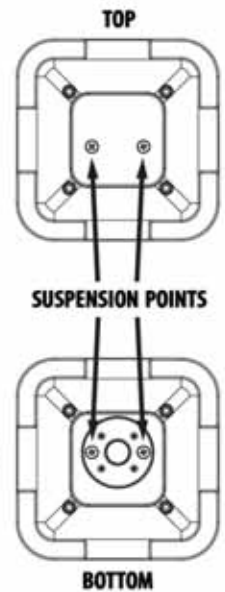
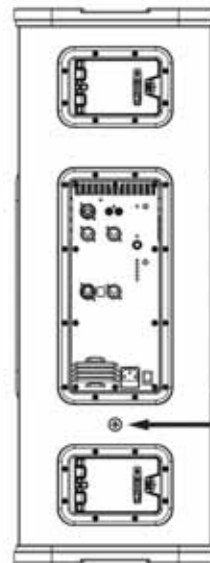
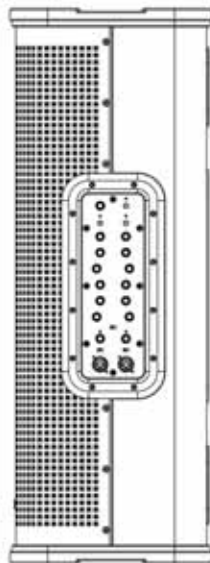
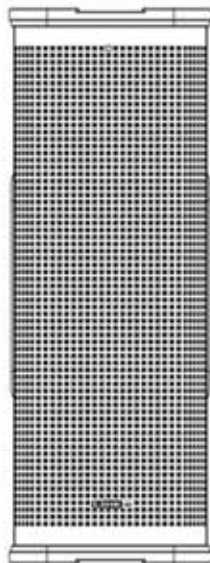
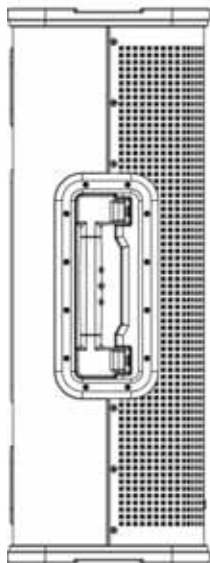
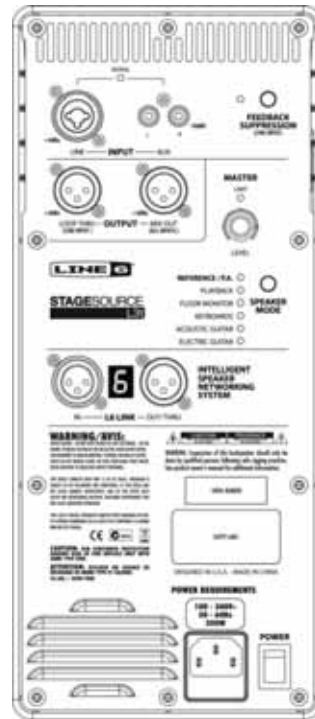

Height	33-7/8" / 861 mm
Width	12-1/4" / 312 mm
Depth	12-1/4" / 312 mm
Weight	57.5 lbs / 26.1 kg

StageSource L3t

The World's Most Versatile Loudspeaker System for Musicians



Technical Specifications

Audio Signal Flow

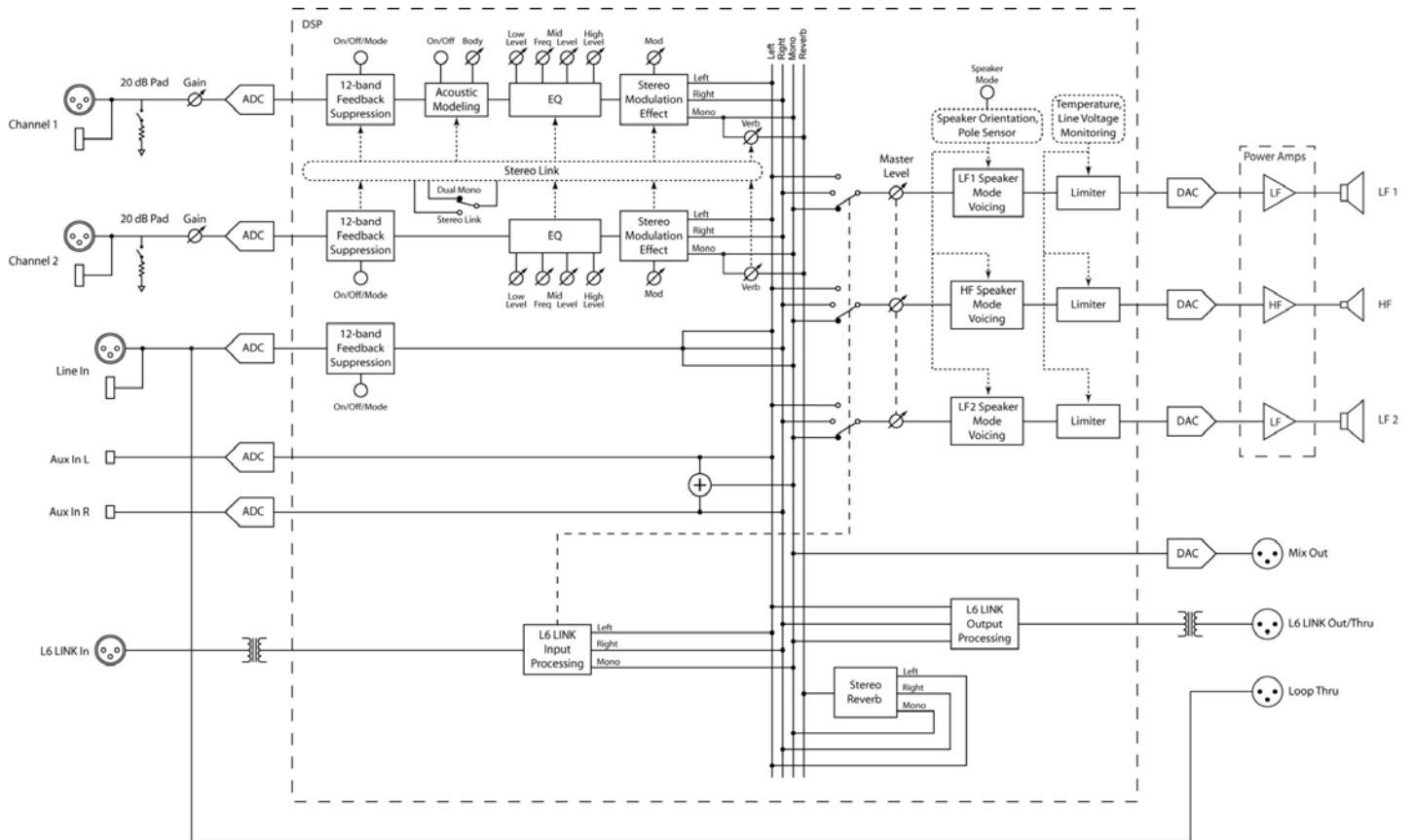

StageSource L3t

The World's Most Versatile Loudspeaker System for Musicians



Technical Specifications

Note: All measurements taken in Reference/P.A. Speaker Mode.

Frequency Response

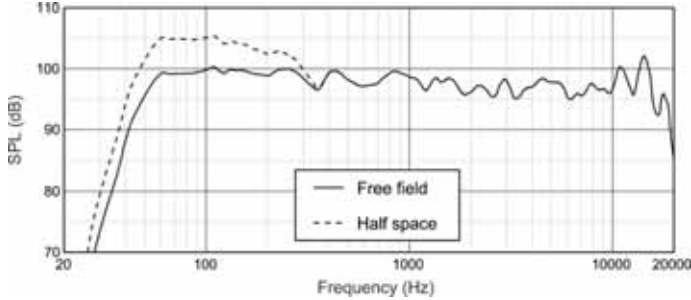

Beamwidth

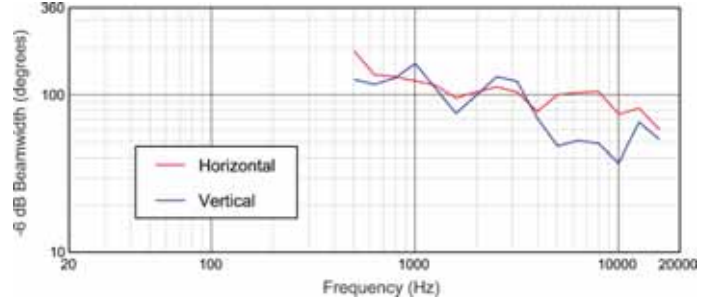

Directivity Index/Factor

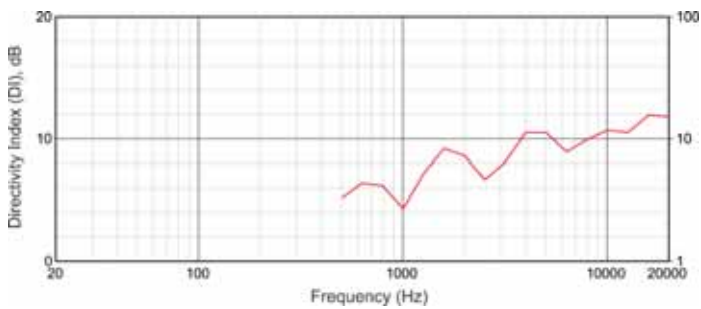

Off-axis, Horizontal

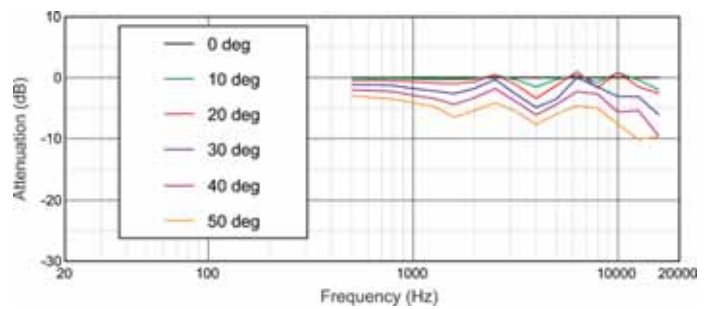

Off-axis, Vertical Down

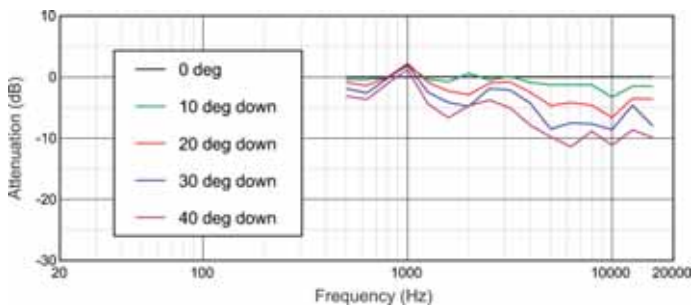

Off-axis, Vertical Up

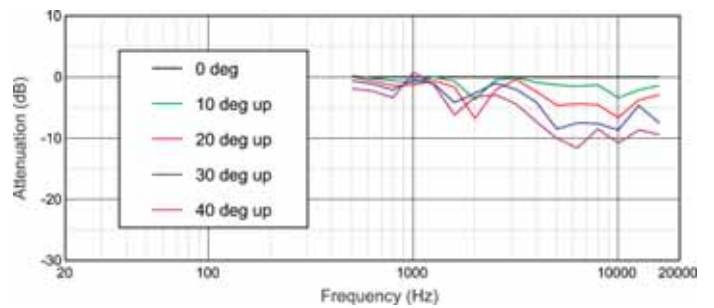

StageSource L3t

The World's Most Versatile Loudspeaker System for Musicians



Technical Specifications

Horizontal Polar Response

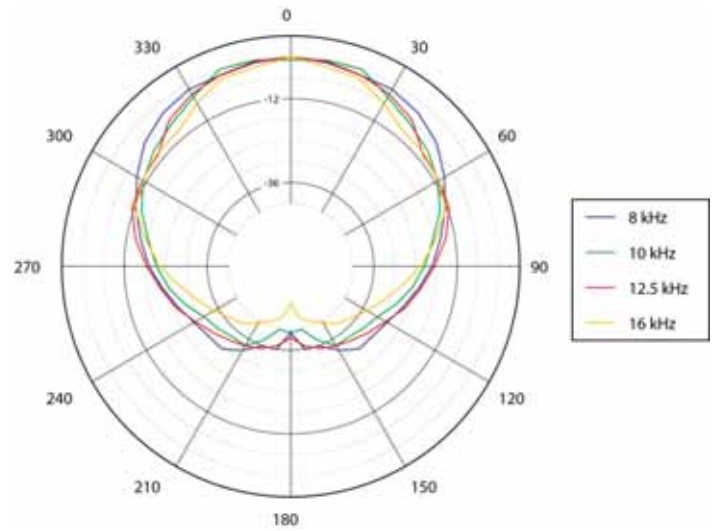
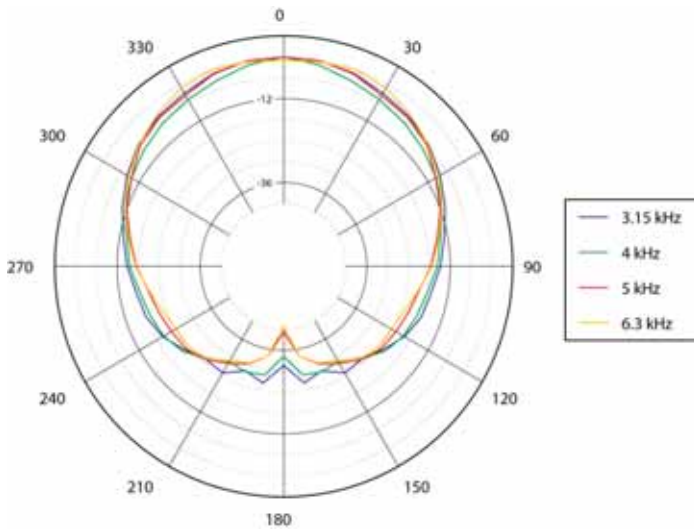
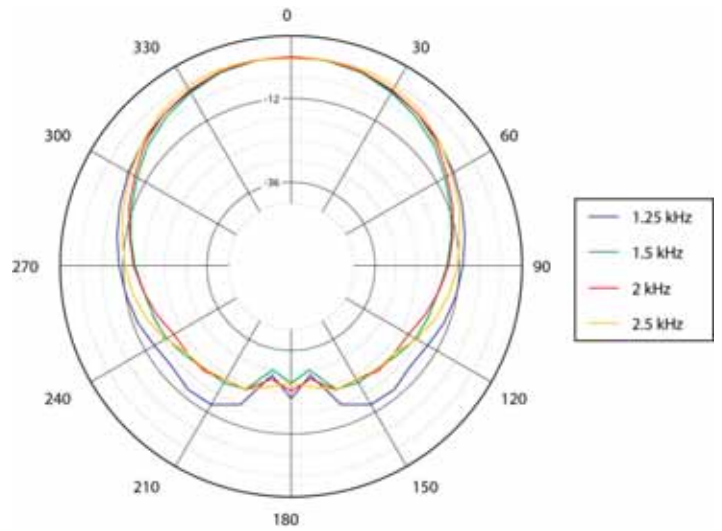
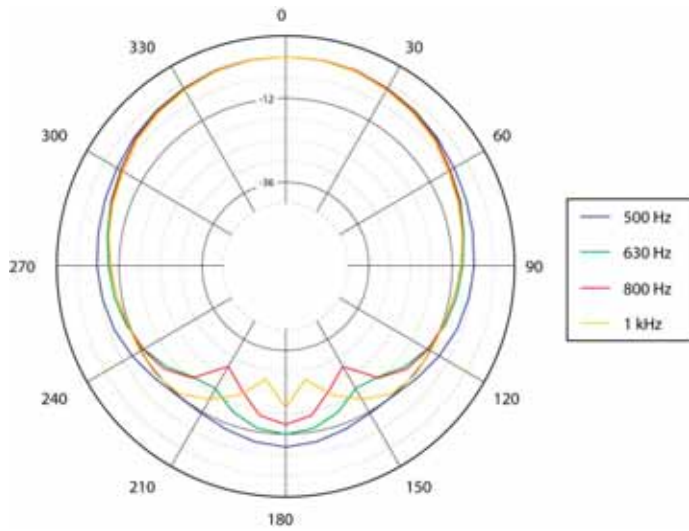

StageSource L3t

The World's Most Versatile Loudspeaker System for Musicians



Technical Specifications

Vertical Polar Response

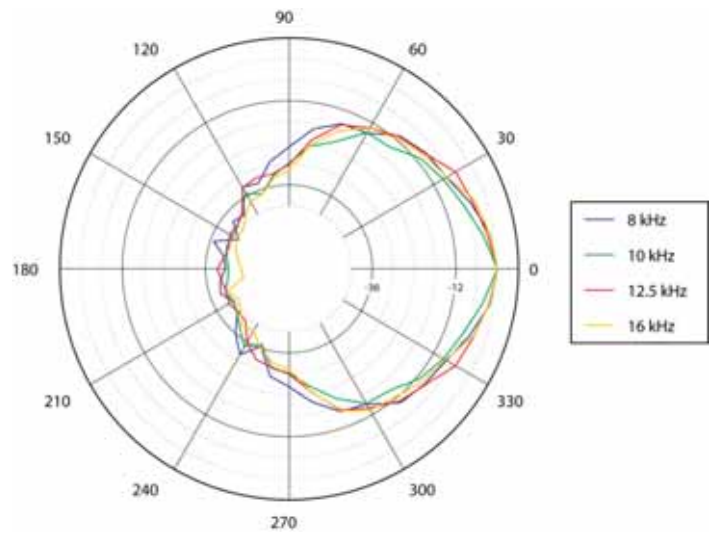
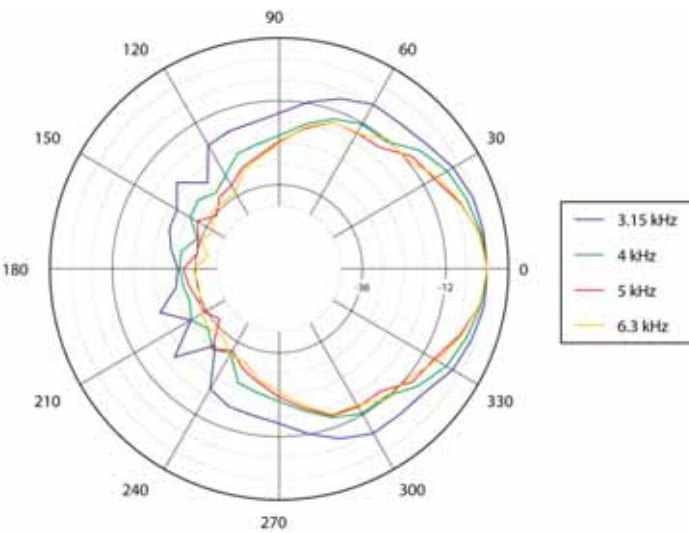
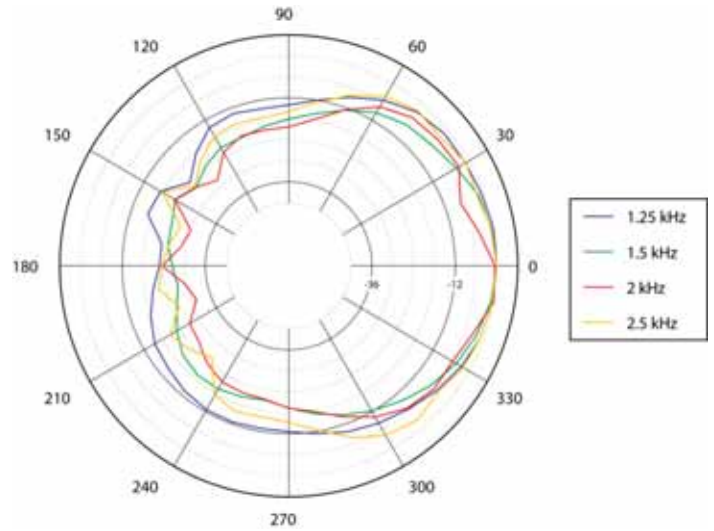
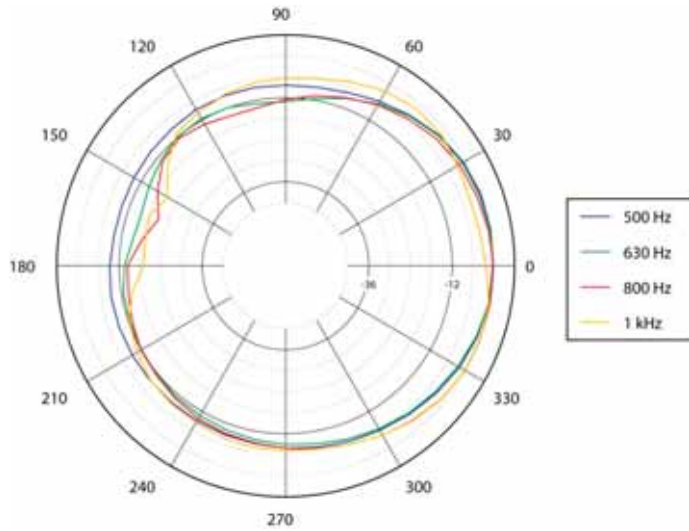

StageSource L3t

The World's Most Versatile Loudspeaker System for Musicians



Technical Specifications

Personal PA

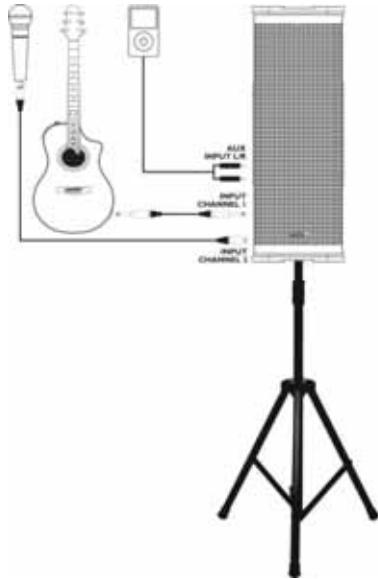

Duet PA

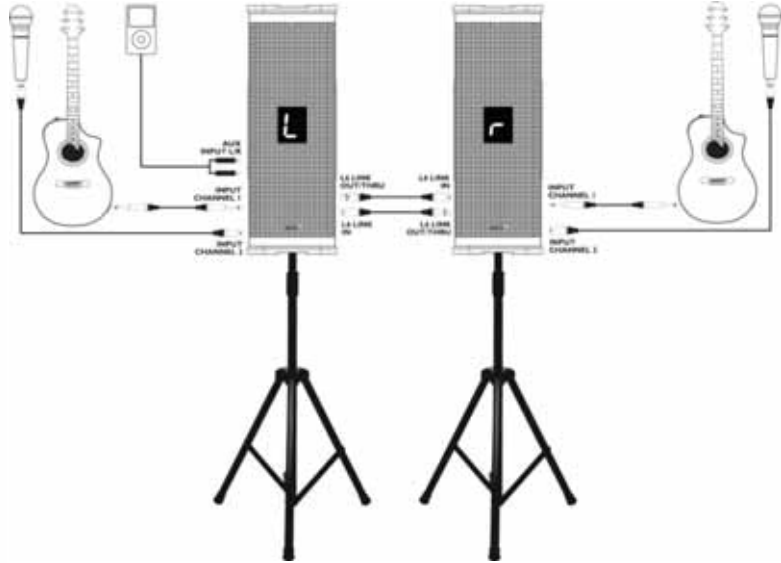

Small Club PA with Subs and Monitor

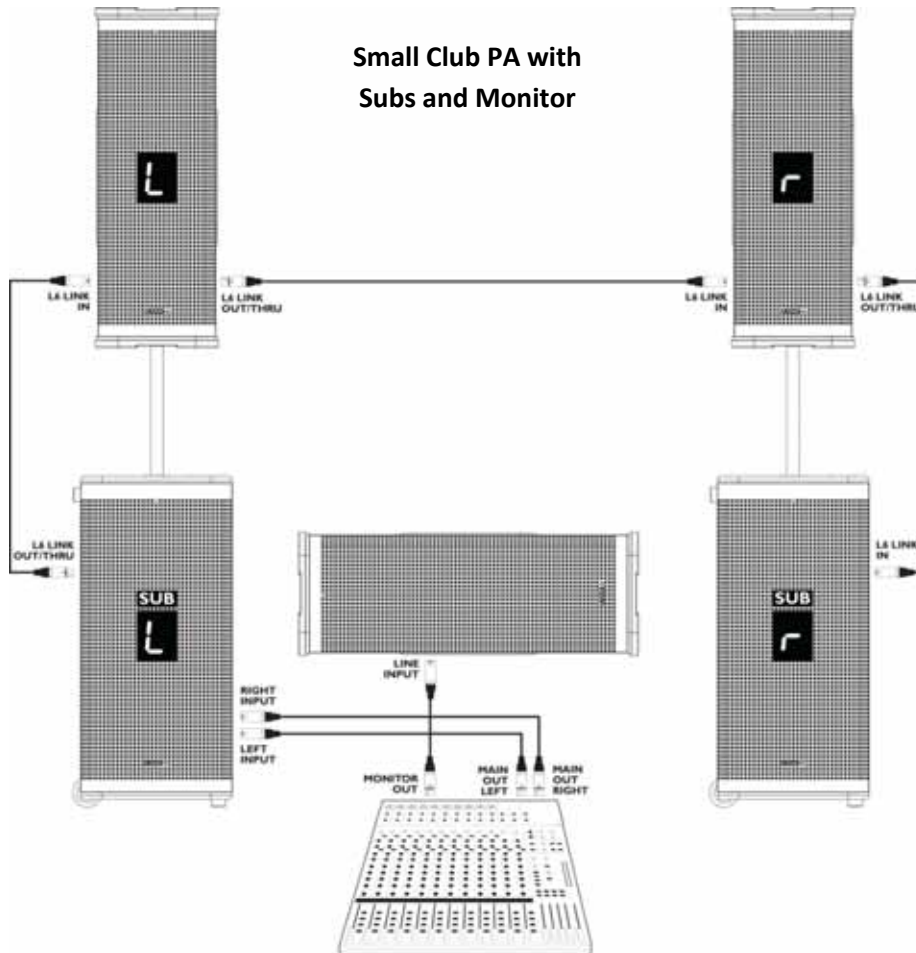

StageSource L3t

The World's Most Versatile Loudspeaker System for Musicians



Technical Specifications

Large Scale PA

