

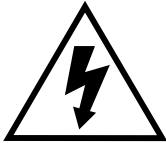

StageSource L3t / L3m / L3s

Pilot's Guide

Important Safety Instructions



CAUTION
RISK OF ELECTRIC SHOCK DO NOT OPEN



WARNING: TO REDUCE THE RISK OF FIRE OR ELECTRIC SHOCK, DO NOT REMOVE SCREWS. NO USER-SERVICEABLE PARTS INSIDE. REFER SERVICING TO QUALIFIED SERVICE PERSONNEL.

WARNING: TO REDUCE THE RISK OF FIRE OR ELECTRIC SHOCK, DO NOT EXPOSE THE APPLIANCE TO RAIN OR MOISTURE.

CAUTION: This equipment has been tested and found to comply with the limits for a Class B digital device pursuant to Part 15 of FCC Rules. Operation is subject to the following two conditions: (1) This device may not cause harmful interference, and (2) this device must accept any interference received, including interference that may cause undesired operation.



The lightning symbol within a triangle means “electrical caution!” It indicates the presence of information about operating voltage and potential risks of electrical shock.



The exclamation point within a triangle means “caution!” Please read the information next to all caution signs.

Please Note:

Line 6 is a trademark of Line 6, Inc. registered in the US and other countries. L3t and L3s are trademarks of Line 6, Inc. All rights reserved.

SERIAL NO: _____



You should read these Important Safety Instructions. Keep these instructions in a safe place



- Read these instructions.
- Keep these instructions.
- Heed all warnings.
- Follow all instructions.
- Do not use this apparatus near water.
- Clean only with dry cloth.
- Do not block any ventilation openings. Install in accordance with the manufacturer's instructions.
- Do not install near any heat sources such as radiators, heat registers, stoves, or other apparatus (including amplifiers) that produce heat.
- This apparatus shall be connected to a MAINS socket outlet with a protective earthing connection.
- Do not defeat the safety purpose of the polarized or grounding-type plug. A polarized plug has two blades with one wider than the other. A grounding type plug has two blades and a third grounding prong. The wide blade or the third prong are provided for your safety. If the provided plug does not fit into your outlet, consult an electrician for replacement of the obsolete outlet.
- Protect the power cord from being walked on or pinched particularly at plugs, convenience receptacles, and the point where they exit from the apparatus.
- Only use attachments/accessories specified by the manufacturer.
- Use only with the cart, stand, tripod, bracket, or table specified by the manufacturer, or sold with the apparatus. When a cart is used, use caution when moving the cart/apparatus combination to avoid injury from tip-over.
- Unplug this apparatus during lightning storms or when unused for long periods of time.
- Refer all servicing to qualified service personnel. Servicing is required when the apparatus has been damaged in any way, such as power-supply cord or plug is damaged, liquid has been spilled or objects have fallen into the apparatus, the apparatus has been exposed to rain or moisture, does not operate normally, or has been dropped.
- The apparatus shall not be exposed to dripping or splashing and that no objects filled with liquids, such as vases, shall be placed on the apparatus.
- **WARNING:** To reduce the risk of fire or electric shock do not expose this apparatus to rain or moisture.
- The appliance coupler is used as the disconnect device, the disconnect device shall remain readily operable.
- Connect only to AC power outlets rated: 100/120V 220/240V 50/60Hz (depending on the voltage range of the included power supply).
- Prolonged listening at high volume levels may cause irreparable hearing loss and/or damage. Always be sure to practice "safe listening."
- Service is required when the apparatus has been damaged in any way, such as:
 - power-supply cord or plug is damaged.
 - liquid has been spilled or objects have fallen into the apparatus.
 - the unit has been exposed to rain or moisture.
 - the unit is dropped or the enclosure is damaged.
 - the unit does not operate normally or changes in performance in a significant way.
- The L3t and L3m provide attachment points for suspending the speaker. The rear panel suspension point is only for adjusting the projection angle.
- Consult an authorized, licensed engineer prior to suspending any speaker overhead. Improper installation may result in damage, injury or death.
- Always follow all municipal building codes, as well as any local, state, and federal safety guidelines regarding the installation and operation of loudspeakers and associated peripherals.



STAGESOURCE L3t / L3M TOWER

For the solo performer or duo, the StageSource L3t is a simple, powerful, and compact integrated live sound solution. Used as a standalone PA system, performers can benefit from a feature set designed to cover all their needs, including a built-in mixer with two mic/instrument inputs, full three-band EQ with sweepable mid, Smart Effects (modulation and reverb), Line 6 acoustic guitar modeling, which improves the output signal of an acoustic guitar outfitted with piezo pickups, and 12-band feedback suppression technology. For larger bands, live sound events, or houses of worship, StageSource L3t can be configured into full front-of-house and monitor systems. Connected via L6 LINK, the proprietary Line 6 networking protocol, StageSource L3t speakers automatically detect each other and adjust their settings accordingly. Used in a system with StageSource L3s subwoofers, crossovers and levels are automatically set for best performance.

The L3t features six innovative Smart Speaker modes, each of which optimizes the speaker's output for a variety of performance scenarios, including front-of-house PA loudspeaker, floor monitor, and speaker for keyboards, acoustic guitars, or with Line 6 POD® multi-effect processors as a high-performance electric guitar backline. Smart Speaker modes can be set manually or with the built-in orientation sensors that can detect whether the speaker has been pole-mounted or tilted for use as a monitor, and adjust the mode accordingly.

When connected via L6 LINK, StageSource speakers and the StageScape M20d digital mixer are capable of unparalleled power and flexibility. Together they explode the typical mixer-speaker paradigm to introduce a smarter live sound experience in which the live rig is a complete, intelligent ecosystem rather than merely a linear combination of components.

The **StageSource L3m** has been specifically designed to meet the needs of anyone who requires a powerful and flexible PA solution. Its feature set is identical to the L3t, with the exception of the multi-channel mixer panel.

Features

- High performance 3-way, tri-amped 1400+ Watt performance
- Smart Speaker Modes for great live sound in any live sound situation
- On-board Accelerometer and Pole-mount sensors
- Virtual Tilt-back projects speaker's output upwards in backline mode
- L6 LINK™ multi-channel digital audio networking for multi-speaker setups
- Multi-channel mixer including 3-band EQ with sweepable mids (L3t only)
- Built-in modulation effects and reverb (L3t only)
- 12-band feedback suppression
- Acoustic guitar modeling for incredible live acoustic guitar tone (L3t only)
- When laid on its side, can be positioned so the speakers fire at an upward angle of 30°, 60°, or 90°.
- Dual-braced tour-grade plywood enclosure
- Full screen backed steel grille
- Retractable handle for easy portability
- Four M10 suspension points and one M10 pullback point

Optional Accessories

- L3t/m speaker bag (98-037-0001)
- Short pole—for mounting on an L3s sub (98-037-0003)
- Long pole—for mounting on an L3s sub (98-037-0004)
- Eyebolt suspension kit (98-037-0005)



STAGESOURCE L3S SUBWOOFER

StageSource L3s is uniquely designed to meet the demanding performance needs of both live *and* pre-recorded music. StageSource L3s can achieve a supremely punchy kick and bass for a live rhythm section and reproduce the deep, controlled sub-bass lows of a DJ rig. Combined with other Line 6 speakers or integrated into a traditional rig, StageSource L3s is far more capable than a standard powered subwoofer, offering advanced DSP, smart design, and true scalability with L6 LINK digital networking.

The L3s features innovative Smart Speaker modes, each of which optimizes the speaker's output for a variety of performance scenarios ranging from flat to extremely bass-heavy. Smart Speaker modes can be set manually or via an L6 LINK™ digital network.

StageSource L3s features L6 LINK, the new multi-channel digital audio networking protocol from Line 6. Connection to other StageSource speakers via L6 LINK triggers the automatic configuration of the system—crossovers and polarity are set and stereo signals are summed as required. The L6 LINK signal transmission between speakers is high-resolution digital audio for maximum sound quality.

When connected via L6 LINK, StageSource speakers and the StageScape M20d digital mixer are capable of unparalleled power and flexibility. Together they explode the typical mixer-speaker paradigm to introduce a smarter live sound experience in which the live rig is a complete, intelligent ecosystem rather than merely a linear combination of components.

Three threaded pole mounts support multiple configurations with other Line 6 speakers. Stereo inputs and out/thrus provide easy integration with traditional live sound gear.

More online at www.line6.com/manuals

While you're online be sure to register your L3 series speaker or simply fill out and mail us your included registration card. Registering gets you all set up for warranty service should you have an issue with your L3 series speaker, and also qualifies you for contests, special offers and more.

Features

- High performance Bi-amped 1200+ Watt performance
- Smart Speaker Modes for great live sound in any live sound situation
- User selectable crossover points
- Stereo outputs allow the L3s to integrate easily with other live sound gear
- L6 LINK™ multi-channel digital audio networking for multi-speaker setups
- Designed for vertical and horizontal deployment
- One threaded pole mount for vertical deployment and two additional threaded pole mounts for horizontal deployment
- Robust, tour-grade enclosure
- Tour-grade steel grille
- Three handles and two built-in wheels for the ultimate in portability

Optional Accessories

- Short pole—for mounting an L3t/L3m tower (98-037-0003)
- Long pole—for mounting an L3t/L3m tower (98-037-0004)
- L3s cover (98-037-0006)

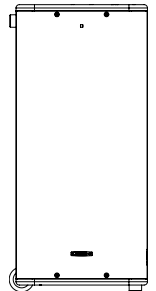

StageSource L3t / L3m

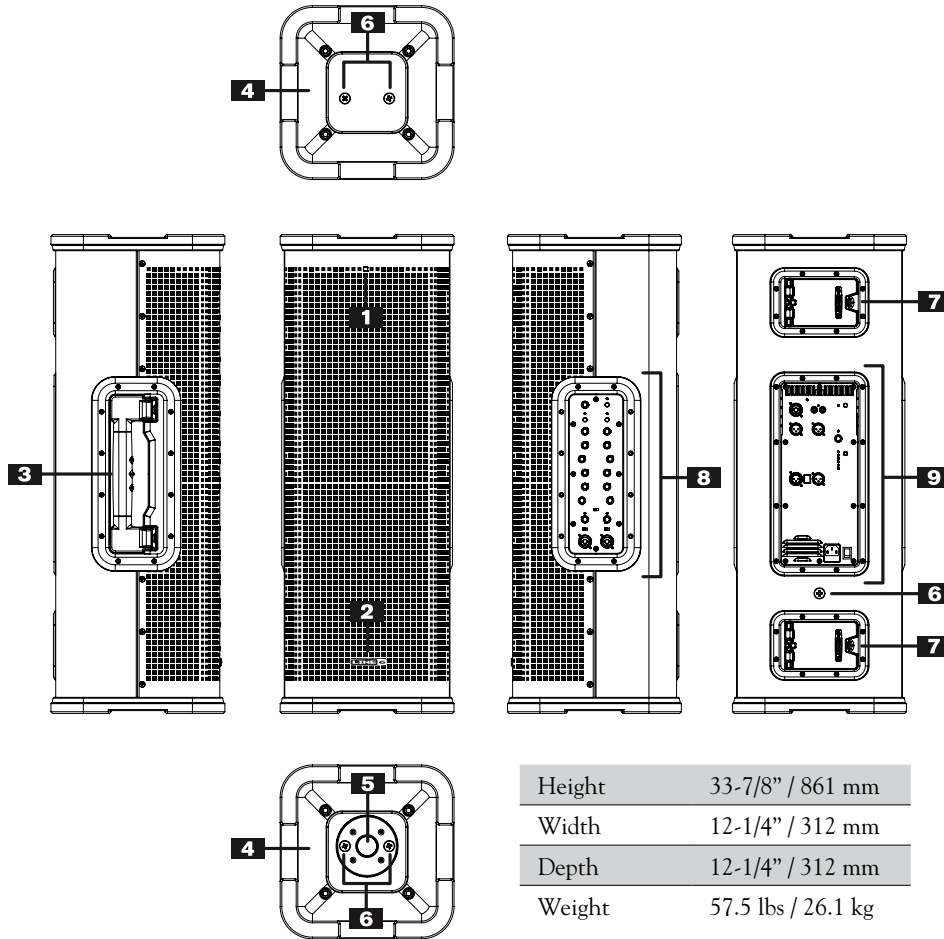

Height	33-7/8" / 861 mm
Width	12-1/4" / 312 mm
Depth	12-1/4" / 312 mm
Weight	57.5 lbs / 26.1 kg

L3t / L3m CALLOUTS

1. **LED** – The front-panel LED glows white when the speaker is powered, flashes red when the limiter circuit is active, and glows blue when receiving communication from StageScape M20d.
2. **Logo** – The Line 6 logo badge can be rotated 90°. Gently pull outward, rotate to match the desired orientation, and snap back into place.
3. **Handle** – This robust carrying handle doubles as a stand, allowing the L3t/L3m to be angled upwards at 30° (see illustration, below left).
4. **Endcaps** – The heavy-duty endcaps double as carrying handles.
5. **Pole Mount and Accelerometer**– The pole mount accommodates standard 35 mm diameter speaker poles. If any “backline” mode is chosen (Keyboard, Acoustic Guitar, Electric Guitar), the L3t/L3m then checks its orientation (via the accelerometer) and looks to see if it is on a pole (via the pole sensor). If the speaker is vertical and not on a pole, the L3t/L3m activates “virtual tilt-back”, which optimizes the speaker tuning to achieve an upward tilt to its main axis. This helps to aim the sound upward towards the performer’s ears when the speaker is placed on the ground. If the speaker is on a pole, virtual tilt-back is not activated. It is assumed that the speaker is elevated and is being aimed in the desired direction.
6. **Suspension Points** – The L3t/L3m has M10 threaded attachment points for suspending the speaker—Two suspension points on the top, two suspension points on the bottom, and one pull-back point on the rear panel.
7. **Kickstands** – Two back-panel kickstands flip out, allowing the L3t/L3m to be angled upwards at 60° (see illustration, below right).
8. **Side Panel (L3t only)** – The side panel contains the musician-centric inputs and controls you’ll use most often. See page 8 for more information.
9. **Rear Panel** – The rear panel contains the P.A.-centric inputs, outputs, and controls. See page 10 for more information.

As floor monitor with handle as stand
(30° upward angle)

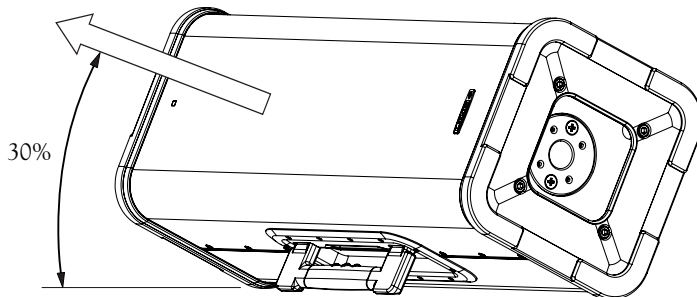

As floor monitor with kick stands
(60° upward angle)

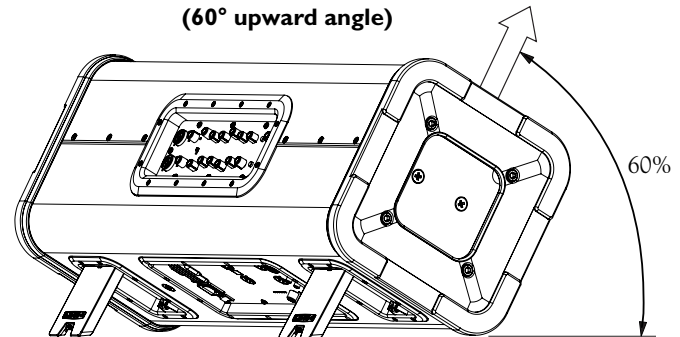

StageSource L3t

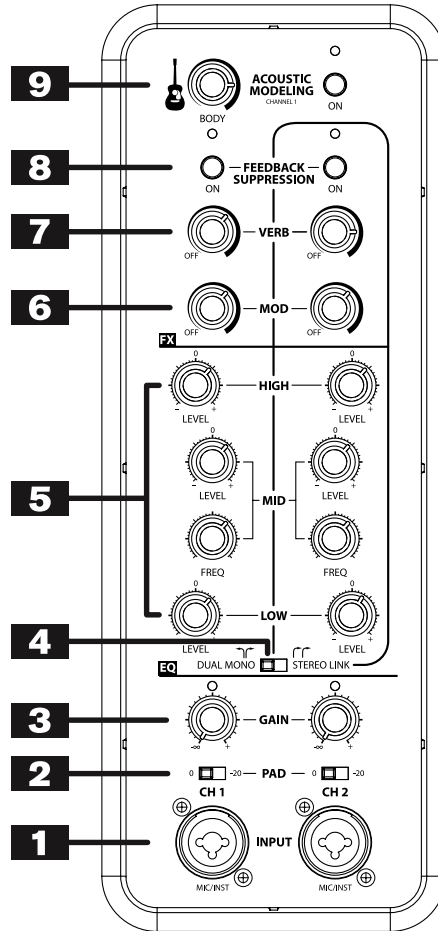

L3t SIDE PANEL

1. **Input Jack** – Connect microphones or line-level equipment to the combi (XLR or 1/4-inch) inputs. The 1/4-inch input can accept unbalanced (Tip-Sleeve) or balanced (Tip-Ring-Sleeve) cables. When connecting an acoustic guitar, use Channel 1.
2. **Pad Switch** – If the input source is particularly loud, enable the -20 dB pad switch.
3. **Channel Gain** – Controls the input level for each channel. The LED above each knob lights green when a signal is present and may flash red if the input is clipped.
4. **Stereo Link Switch** – When the Stereo Link switch is set to Dual Mono, each of the two channels retains its own settings. When connecting a stereo source to the two inputs, it can be convenient to have a single set of controls adjust both signals simultaneously. Placing this switch in Stereo Link mode disables Channel 1's controls and allows Channel 2's controls to affect both inputs. When using a single L3t, all stereo signals are summed to mono before being output to the speaker.

If a second L3t is connected via L6 LINK, stereo signals will be split automatically between the two speakers. See page 16 for more details.

Note that the Acoustic Modeling circuit applies to Channel 1 only, so it is disabled in Stereo Link mode.

5. **EQ** – Each channel has its own three band EQ, adjustable from -12 dB to +12 dB (unity is 0 dB). The Low band is fixed at 80 Hz, the Mid band is sweepable from 100 Hz to 8 kHz (center position is at 800 Hz) with a fixed bandwidth of 0.7 octaves, and the high band is fixed at 12 kHz.
6. **Mod** – Determines the amount of built-in modulation effect applied to the channel. The modulation effect is similar to vocal doubling, but works equally well on acoustic guitar or keyboards. If a second L3t or L3m is connected via L6 LINK, modulation will automatically be heard in stereo.
7. **Verb** – Determines the amount of built-in hall reverb applied to the channel. The reverb is taken from the StageScape M20d digital mixer, and is optimized for live sound reinforcement. If a second L3t is connected via L6 LINK, reverb will automatically be heard in stereo.
8. **Feedback Suppression** – Feedback suppression works by continuously analyzing the audio signal, identifying frequencies that have the characteristics of feedback (steady frequencies with few overtones, rising in amplitude), and then applying a narrow notch filter to remove the offending frequency. Up to 12 independent feedback frequencies can be removed with the L3t's Feedback Suppression.

Press the On button to enable or disable Feedback Suppression. Each time the Feedback Suppression is turned off, all filters are reset. When Feedback Suppression is turned back on, analysis begins again and if feedback is detected again, the filters are turned back on.

The feedback analyzer can be set to one of three modes, depending on how aggressively the analysis will seek out potential feedback frequencies. Press and hold the On button to select between aggressive (red), medium (amber), or mild (green).

9. **Acoustic Modeling** – Most acoustic guitars utilize a piezo pickup that captures string vibrations but typically does not convey the guitar's body resonance as well as a microphone in front of a guitar would. The Acoustic Modeling feature of the L3t is based on Line 6's Variax Acoustic technology, in which a physical model of an acoustic guitar's natural body resonance is applied to the piezo signal to simulate the sound of a mic'ed acoustic guitar in the studio. The Acoustic Modeling feature is available for Channel 1.

Press the On button to enable or disable Acoustic Modeling; turn the Body knob to set the amount of body resonance.

StageSource L3t / L3m

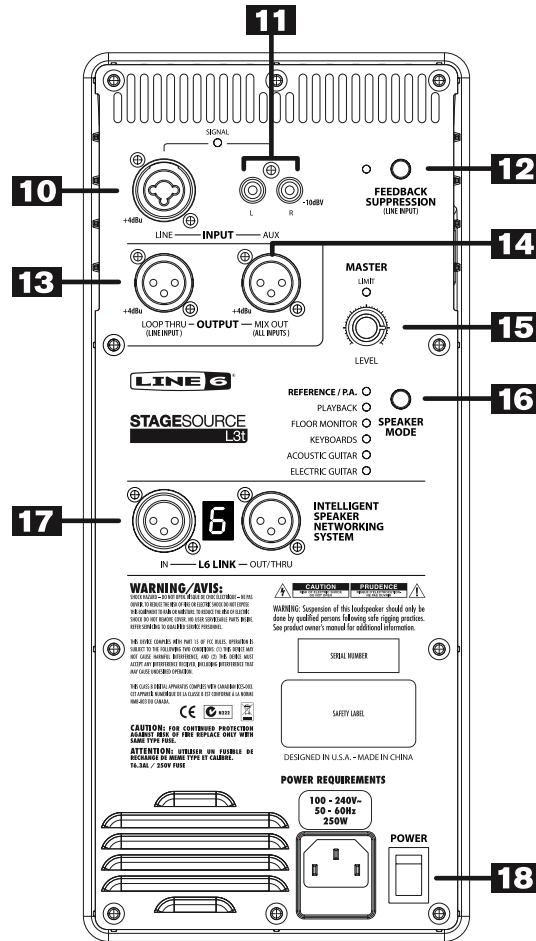

L3t / L3m BACK PANEL

- 10. Line Input** – Connect the line-level output of your mixer to the combi (XLR or 1/4-inch) Line input. The 1/4-inch input can accept unbalanced (Tip-Sleeve) or balanced (Tip-Ring-Sleeve) cables. The Signal LED lights green when a signal is present and may flash red if the input is clipped.
- 11. L&R Aux Inputs** – These L&R stereo RCA jacks are for connecting the audio output of a DJ mixer, MP3 player, or CD/DVD player. When using a single L3t/L3m speaker, the left and right inputs are summed to mono. If a second L3t or L3m is connected via L6 LINK, the left and right Aux Inputs will be automatically split between the two speakers. See page 16 for more information.
- 12. Feedback Suppression** – Turns on the 12-band feedback suppression circuit for the Mixer Input channel. Press the On button to enable or disable Feedback Suppression; press and hold the On button to select aggressive (red), medium (amber), or mild (green) Feedback Suppression.
- 13. Loop Thru Output** – This output duplicates the signal received at the Line input jack.
- 14. Mix Out Output** – This output sends a mix of all three channels (Channel 1, Channel 2, and back panel inputs)
- 15. Master Level** – Sets the overall output level. The Limit LED lights if the Master Limiter kicks in.
- 16. Speaker Mode** – L3t/L3m can be optimized for various applications. Press the Speaker Mode button to cycle between Reference/P.A., Playback, Floor Monitor, Keyboards, Acoustic Guitar, or Electric Guitar. See the table below for more information.
- 17. L6 LINK™** – This connection provides a powerful, proprietary digital link between various L6 LINK-compatible products, enabling easy, reliable, one-cable connectivity. In the case of L3t/L3m, L6 LINK-connected speakers can be daisy-chained, allowing all products to sync and communicate uniquely with each other. When two or more L3t or L3m speakers are connected via L6 LINK, the 7-segment display indicates whether each speaker is left (“L”), right (“R”), or L+R mono (“b”). When used with a StageScape mixer, the 7-segment display identifies each speaker with a number.
- 18. Power Switch** – Turns the speaker on and off.

Speaker Mode	Description
Reference/P.A.	This is the recommended mode for live sound reinforcement, with a flat frequency response, a 2.2 kHz crossover frequency, and maximum low frequency extension.
Playback	Optimized for prerecorded music; similar to P.A. mode with an emphasis at extreme low and high frequencies.
Floor Monitor	Similar to P.A. mode with a slight reduction in low frequency content to counteract coupling when placing the speaker on the floor. If the speaker is powered on while in a horizontal position, Floor Monitor speaker mode will be selected automatically. The user can then change to a different mode, if desired.
Keyboards	Flat frequency response with a 3.5 kHz crossover frequency; provides a warmer response that’s better for instruments, and adds more relative energy from the cone.
Acoustic Guitar	3.5 kHz crossover frequency, with a tailored low-frequency response to minimize boominess.
Electric Guitar	The overall frequency response emulates the sound of a 212 combo amp. The 10” speaker plays full range, with the horn adding only the smallest amount of sparkle.

StageSource L3s

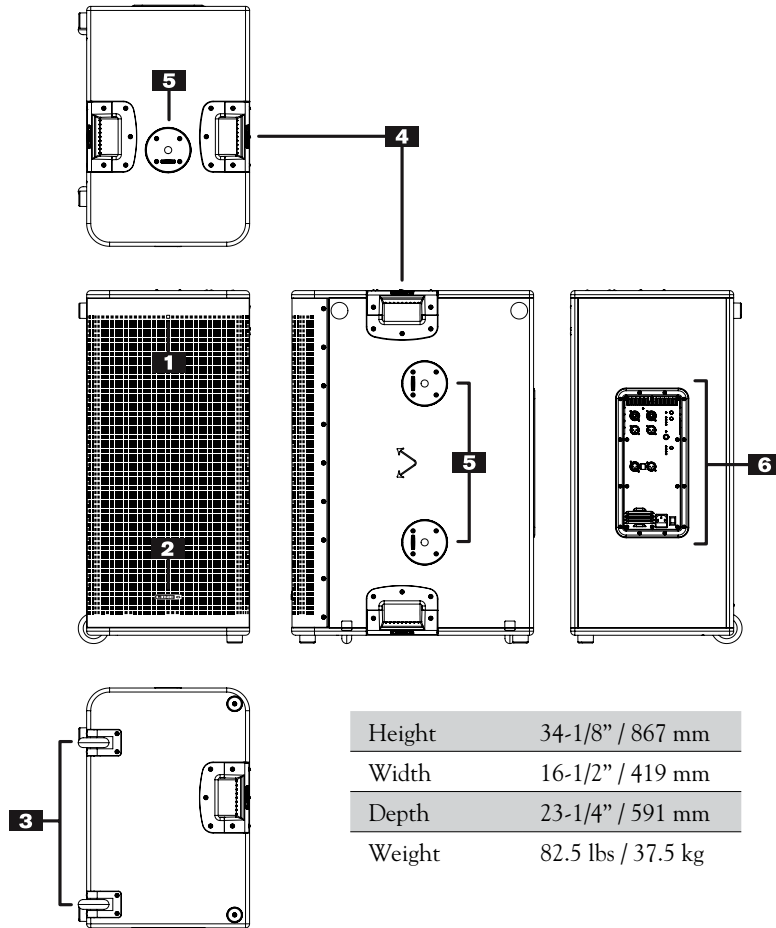

Height	34-1/8" / 867 mm
Width	16-1/2" / 419 mm
Depth	23-1/4" / 591 mm
Weight	82.5 lbs / 37.5 kg

L3s CALLOUTS

1. **LED** – The front-panel LED glows white when the speaker is powered, flashes red when the limiter circuit is active, and glows blue when receiving communication from StageScape M20d.
2. **Logo** – The L3s's Line 6 logo badge can be rotated 90°. Gently pull outward, rotate to match the desired orientation, and snap back into place.
3. **Wheels** – These 70 mm wheels allow easy transport of the L3s.
4. **Handles** – The L3s has three heavy-duty handles for easy transportation.
5. **Pole Mounts**– Three threaded pole mounts (one on top, two on the right side) accommodate Line 6 M20 threaded speaker poles.
6. **Rear Panel** – The rear panel contains all inputs, outputs, and controls. See page 14 for more information.

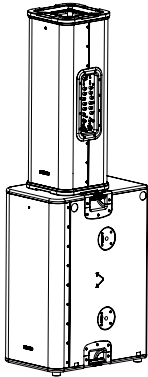

L3s sub with one L3t tower (on stage)

Use one short speaker pole (not included)

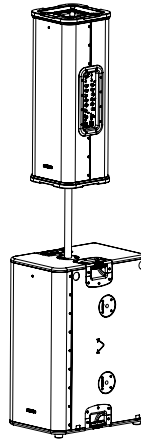

L3s sub with one L3t tower (on floor or low stage)

Use one long speaker pole (not included); never use any pole longer than 24-3/4" (626 mm) in this configuration

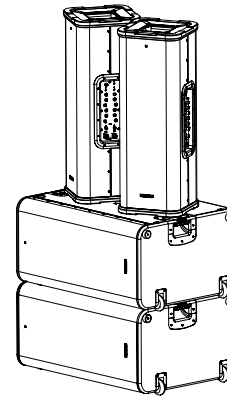

L3s sub with two L3t towers

Use two short speaker poles (not included); never use any pole longer than 27-1/2" (700 mm) in this configuration; angle the L3t towers in the direction of the arrows routed into the L3s's side panel

StageSource L3s

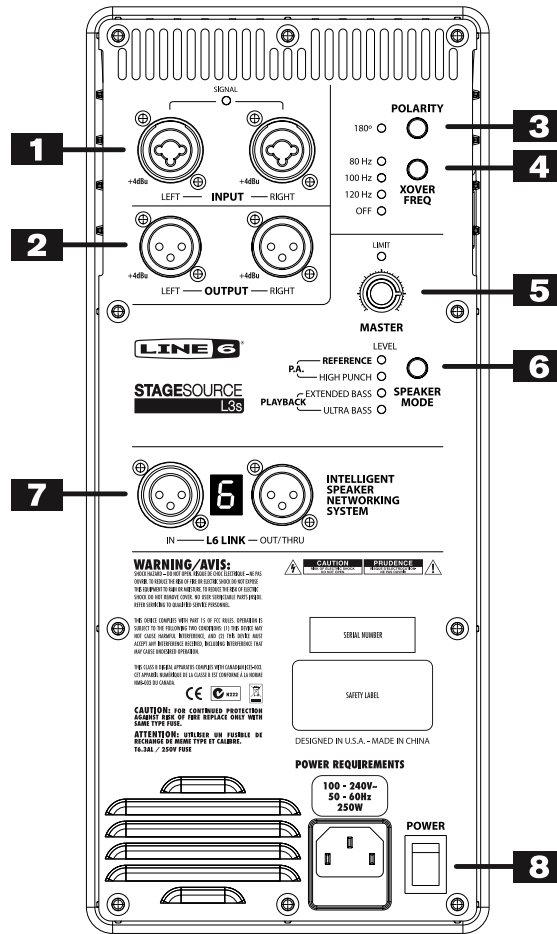

L3s BACK PANEL

- 1. Inputs** – Connect the line-level outputs of your mixer to the combi (XLR or 1/4-inch) inputs. The 1/4-inch input can accept unbalanced (Tip-Sleeve) or balanced (Tip-Ring-Sleeve) cables. The Signal LED lights green when a signal is present and may flash red if the input is clipped.
- 2. Outputs** – These outputs send a line-level version of the signals received at the Input jacks, with any high-pass filtering applied (determined by the Xover Freq setting). The Outputs are used to pass high frequency content of the audio input through to non-Line 6 full range speakers. When using the L3s with L3t speakers, the L6 LINK connection can be used instead for digital audio and automatic configuration of the system.
- 3. Polarity** – Press the Polarity button to invert the polarity of the signal driving the L3s's two 12-inch woofers. When the LED is lit, the signal's polarity is inverted.
- 4. Xover Freq** – Press the Xover Freq button to select the low-pass crossover frequency of the signals delivered to both the internal 12-inch woofers and Stereo Outputs: 80 Hz, 100 Hz, 120 Hz, or Off.
- 5. Master Level** – Sets the overall output level of L3s. The Limit LED lights if the Master Limiter kicks in.
- 6. Speaker Mode** – L3s can be optimized for various applications. Press the Speaker Mode button to cycle between Reference, High Punch, Extended Bass, or Ultra Bass. See the table below for more information.
- 7. L6 LINK™** – This connection provides a powerful, proprietary digital link between various L6 LINK-compatible products, enabling easy, reliable, one-cable connectivity. In the case of L3s, L6 LINK-connected speakers can be daisy-chained, allowing all products to sync and communicate uniquely with each other. When two or more L3s speakers are connected via L6 LINK, the 7-segment display indicates whether each speaker is left (“L”), right (“r”), or L+R mono (“b”). When used with a StageScape mixer, the 7-segment display identifies each speaker with a number.
- 8. Power Switch** – Turns the L3s on and off.

Speaker Mode	Description
Reference	Optimized for live performance, delivers relatively flat frequency response across the L3s's widest bandwidth
High Punch	Supplies a slight emphasis at 80 Hz for enhanced kick drum impact
Extended Bass	Optimized for playback of prerecorded music
Ultra Bass	Similar to Extended bass, but with an underdamped, extended low frequency response

ABOUT L6 LINK™

L6 LINK is a proprietary digital networking protocol developed by Line 6 to enable easy, reliable, one-cable connectivity between various Line 6 products.

Up to nine L3t/L3m *and* nine L3s speakers can be connected via L6 LINK, and channel assignment is automatic, with the first speaker in the chain (master) providing the digital audio channels distributed to all other speakers in the network. All L3s and vertically-oriented L3t/L3m speakers follow channel assignment shown in the table below. For example, connecting two upright L3t or L3m speakers together automatically configures them as left and right. Connecting three upright L3t/L3m speakers together configures them as left, mono center (left + right), and right. Placing any L3t/L3m in the L6 LINK network on its side assumes it will be used as a floor monitor, configures it as left + right, and the remaining speakers follow the behavior in the table below. Each speaker's rear panel L6 LINK display will indicate the current assignment: Left ("L"), right ("r"), or L + R ("b" for both).

When connecting one or more L3s subs with L3t or L3m towers, crossover points are selected automatically.

When used in conjunction with a StageScope M20d mixer, channel assignments behave as above, except any L3t or L3m speakers laid on their side are, by default, fed by monitor feed A, B, C, and D, respectively. Furthermore, any speaker on the network can have its channel assignment changed manually from the StageScope M20d touch screen interface. In this case, each speaker's rear panel L6 LINK display will indicate its sequential number in the network. L3t/L3m and L3s speakers are numbered independently.

We strongly recommend the use of 110-ohm AES/EBU digital cables for use with Line 6 LINK connections for StageScope and StageSource. The use of standard XLR cables may yield inconsistent results because of the varying quality of commercially-available XLR cables. Cables longer than 50 feet are not recommended for L6 LINK.

Number of L3s or Vertical L3t/L3m speakers	Default Audio Channel Assignment								
	Spkr 1	Spkr 2	Spkr 3	Spkr 4	Spkr 5	Spkr 6	Spkr 7	Spkr 8	Spkr 9
1	L + R								
2	L	R							
3	L	L + R	R						
4	L	L	R	R					
5	L	L	L + R	R	R				
6	L	L	L	R	R	R			
7	L	L	L	L + R	R	R	R		
8	L	L	L	L	R	R	R	R	
9	L	L	L	L	L + R	R	R	R	R

SUSPENDING THE L3t / L3m

The L3t and L3m provide four threaded M10 attachment points for suspension and one threaded M10 attachment point for pull-back and aiming the speaker. These are designed to allow for suspending the loudspeaker only by a qualified professional familiar with safe rigging practices. Improper installation may result in damage to the speaker or support structure, or injury or death.

WARNING! If you are unfamiliar with suspending loudspeakers, consult an authorized, qualified professional prior to installation.

WARNING! Before rigging or suspending any loudspeaker product, inspect all rigging hardware, cabinets, attachment points, transducers, and associated peripherals. Any absent, warped, or non-load rated equipment could seriously compromise the strength of the installation and should be immediately corrected.

WARNING! Always follow all municipal building codes, as well as any local, state, and federal safety guidelines regarding the installation and operation of loudspeakers and associated peripherals.

Always use two attachment points on either the top or bottom of the L3t/L3m. The rear panel pull-back attachment point is *only* for aiming the speaker downwards; it is not to be used as a load-bearing suspension point. Furthermore, suspension points are for hanging the speaker only; do not suspend additional speakers or other items from suspension points.

For permanent installations, use *only* the Line 6 eyebolt kit (part no. 98-037-0005).

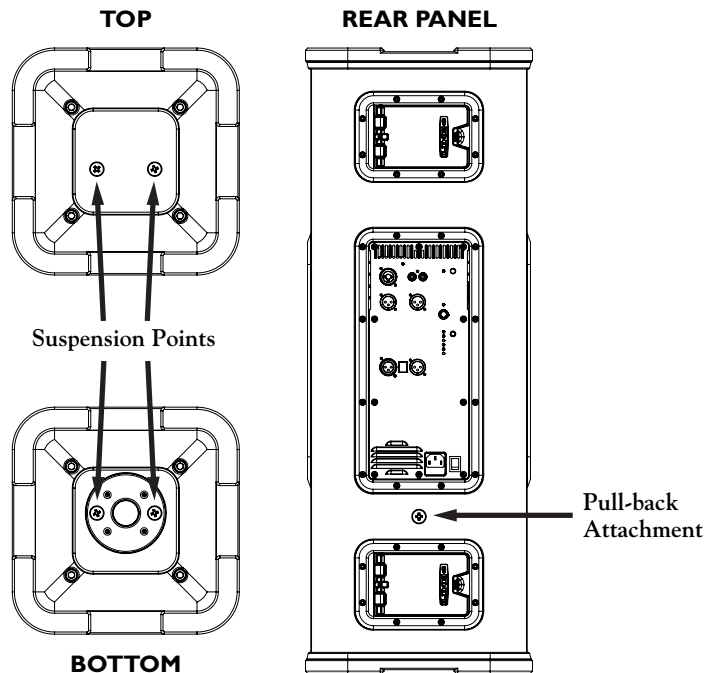

Traditional Applications

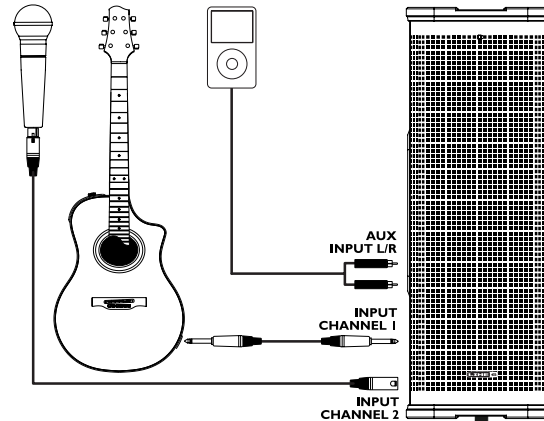

SOLO ARTIST

L3t can provide portable amplification for singer-songwriters, complete with EQ, reverb and modulation for each channel.

Connect your acoustic guitar to the side panel Channel 1, which features Acoustic Modeling.

Connect your microphone to the side panel Channel 2.

Connect a portable media player, CD player, or DJ mixer to the rear panel Aux L/R inputs for backing accompaniment or intermission music.

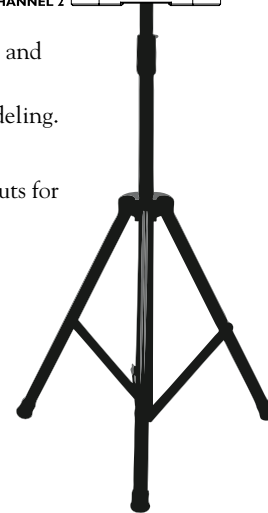

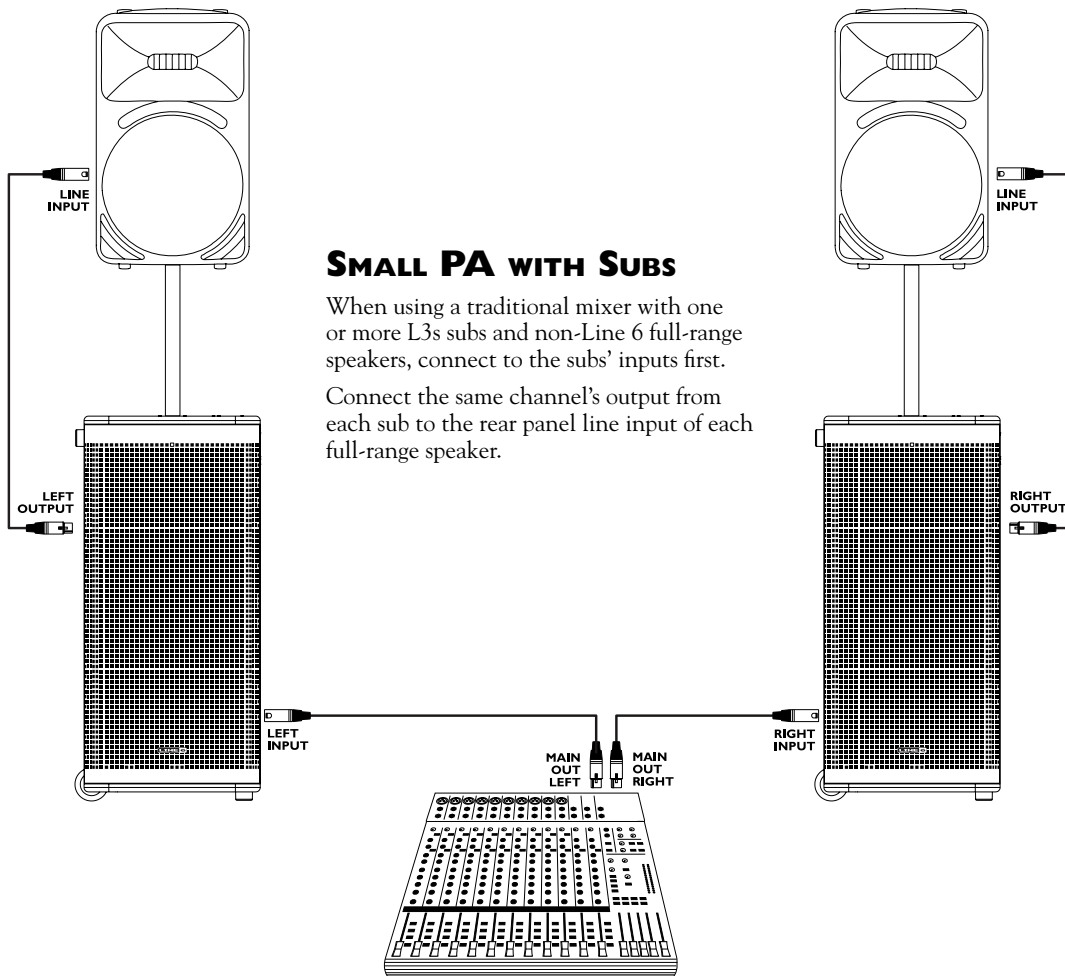

Applications with L6 LINK™

SMALL CLUB DUET

L6 LINK provides an easy way for two artists—each with an L3t—to blend their signals together without the need for an external mixer.

Connect the guitars to each speaker's Channel 1, which features Acoustic Modeling.

Connect the microphones to Channel 2.

When two L3t speakers are connected together as an L6 LINK loop, (L6 LINK In of each speaker connected to the L6 LINK Out of the other), this stereo system can take advantage of both side mixer panels combined. All of the left and mono signals from both speakers' inputs will play from the speaker labeled "L", and all of the right and mono signals will play from the speaker labeled "r". In this configuration example, two guitars and two microphones, and even two MP3 players could be used simultaneously.

If the second tower's input panel is not required, an L3m can be used in its place.

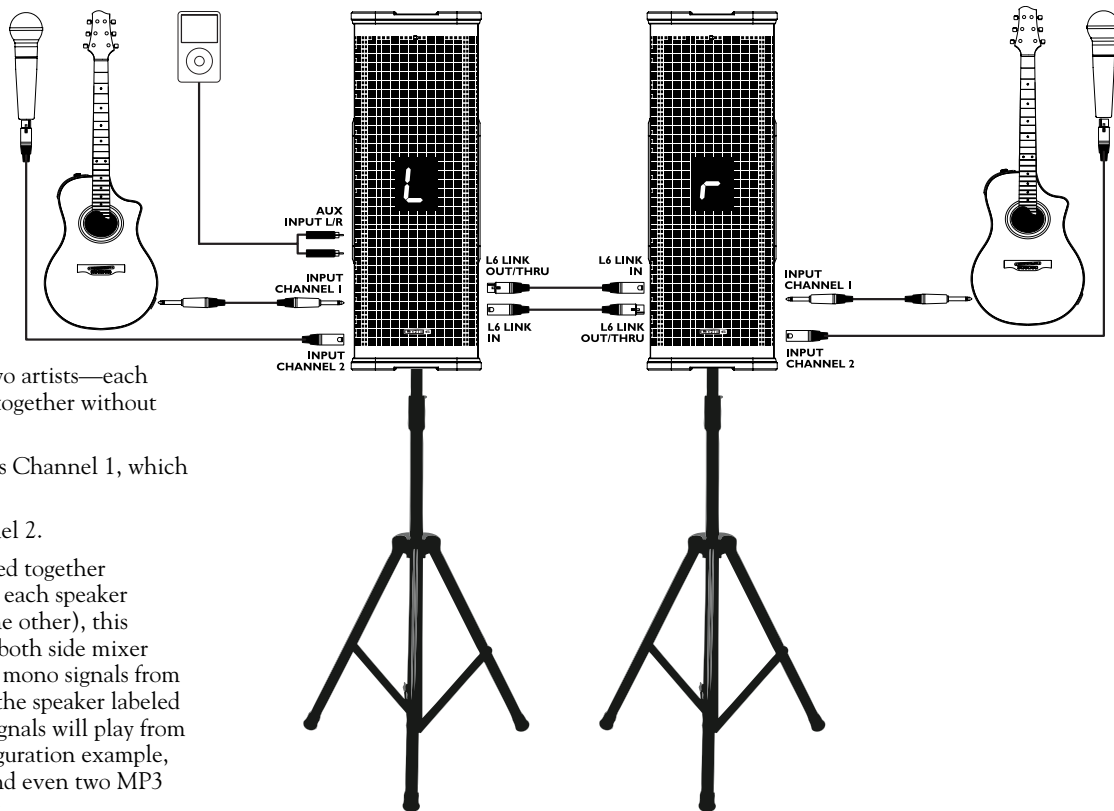

SMALL PA WITH SUBS

When using a traditional mixer with one or more L3t/L3m towers and one or more L3s subs connected via L6 LINK, connect both the Main Left and Main Right outputs of the mixer to one L3s's Left and Right inputs.

Connect the L3s's L6 LINK Out/Thru to an L3t or L3m you wish to designate as left.

Continue daisy-chaining speakers via L6 LINK. L3 subs and towers will automatically configure themselves as left, right, or mono (left + right), according to the table on page 16.

In the illustration to the right, the first sub and first tower are designated left. As there are only two subs and two towers, the other L3t/L3m and L3s are automatically designated right.

The floor monitor is connected via traditional means from the mixer's monitor output.

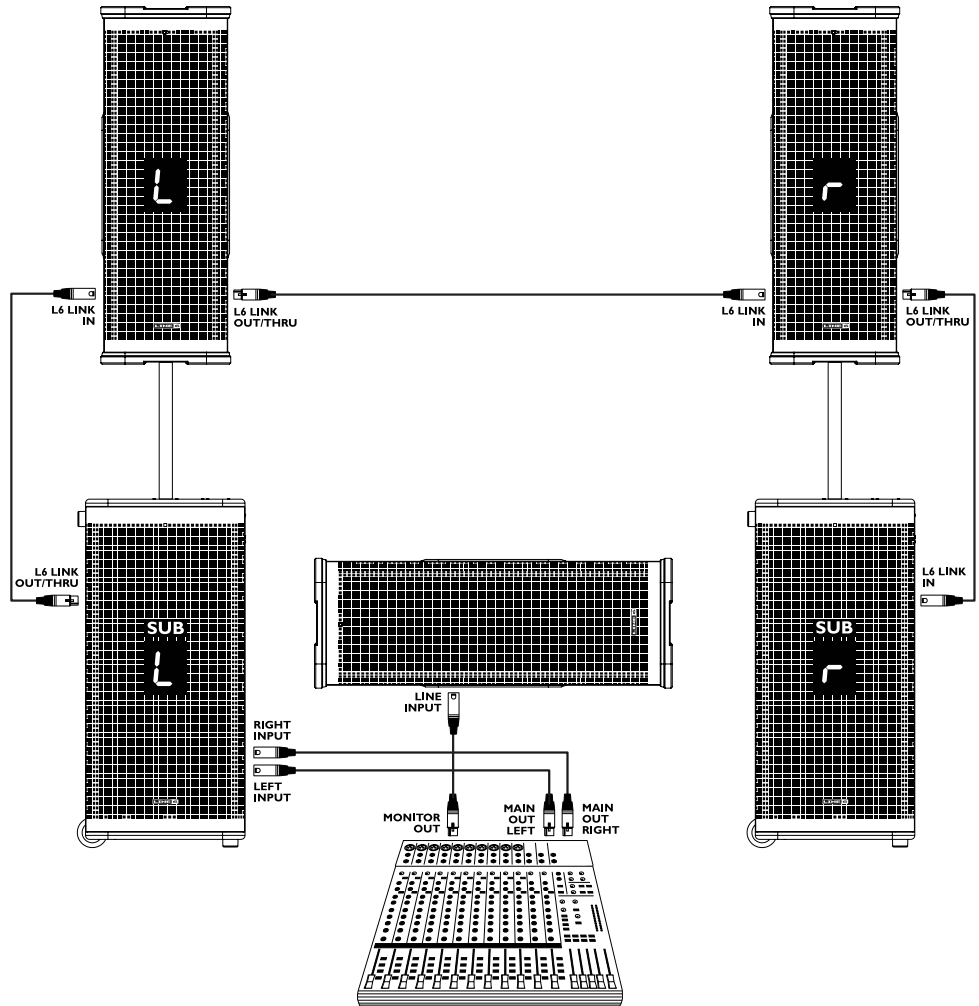

LARGE PA WITH SUBS

When using a traditional mixer with one or more L3t/L3m towers and one or more L3s subs connected via L6 LINK, connect both the Main Left and Main Right outputs of the mixer to one L3s's Left and Right inputs.

Continue daisy-chaining speakers via L6 LINK.

Any L3 subs and towers will automatically configure themselves as left, right, or mono (left + right), according to the table on page 16.

In this illustration, the three floor monitors exist on a separate L6 LINK network, and as they're turned on their sides, will automatically sum the left and right channels of any signals received ("b" for both).

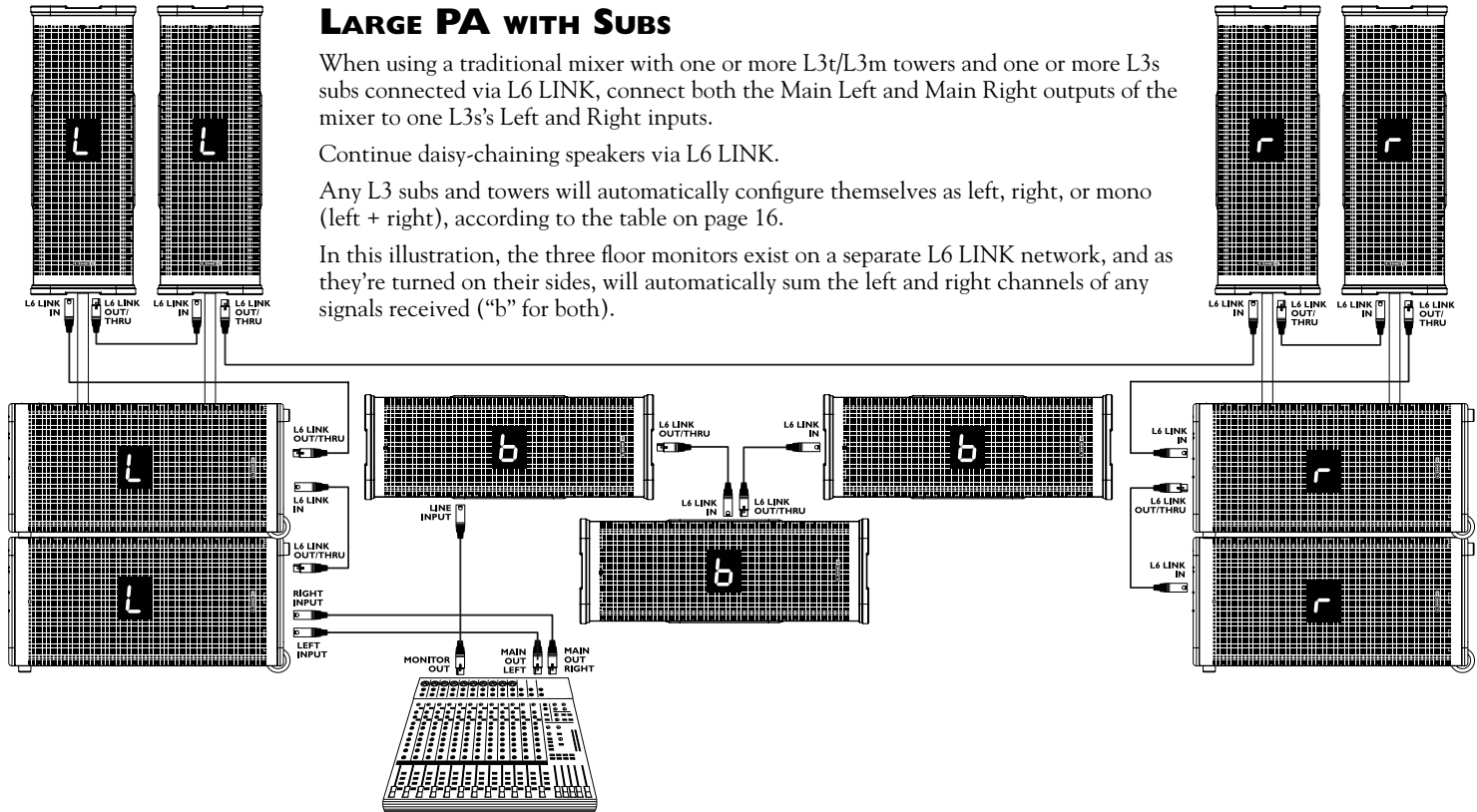

STAGESCAPE M20d—SMALL PA

Connect the L6 LINK out from a StageScape M20d mixer to the rear panel L6 LINK In on any speaker in the network.

Any L3t/L3m towers and L3s subs on an L6 LINK network are numbered independently.

In this illustration, the two L3s subs (labeled SUB 1 and 2) will, by default, play left and right, respectively. The two upright L3t/L3m towers (numbered 1 and 3) will, by default, play left and right, respectively. L3t/L3m number 2, because it's laid on its side, will automatically play discrete monitor feed A.

Any speaker on the network can have its channel assignment changed from the M20d's touch screen interface.

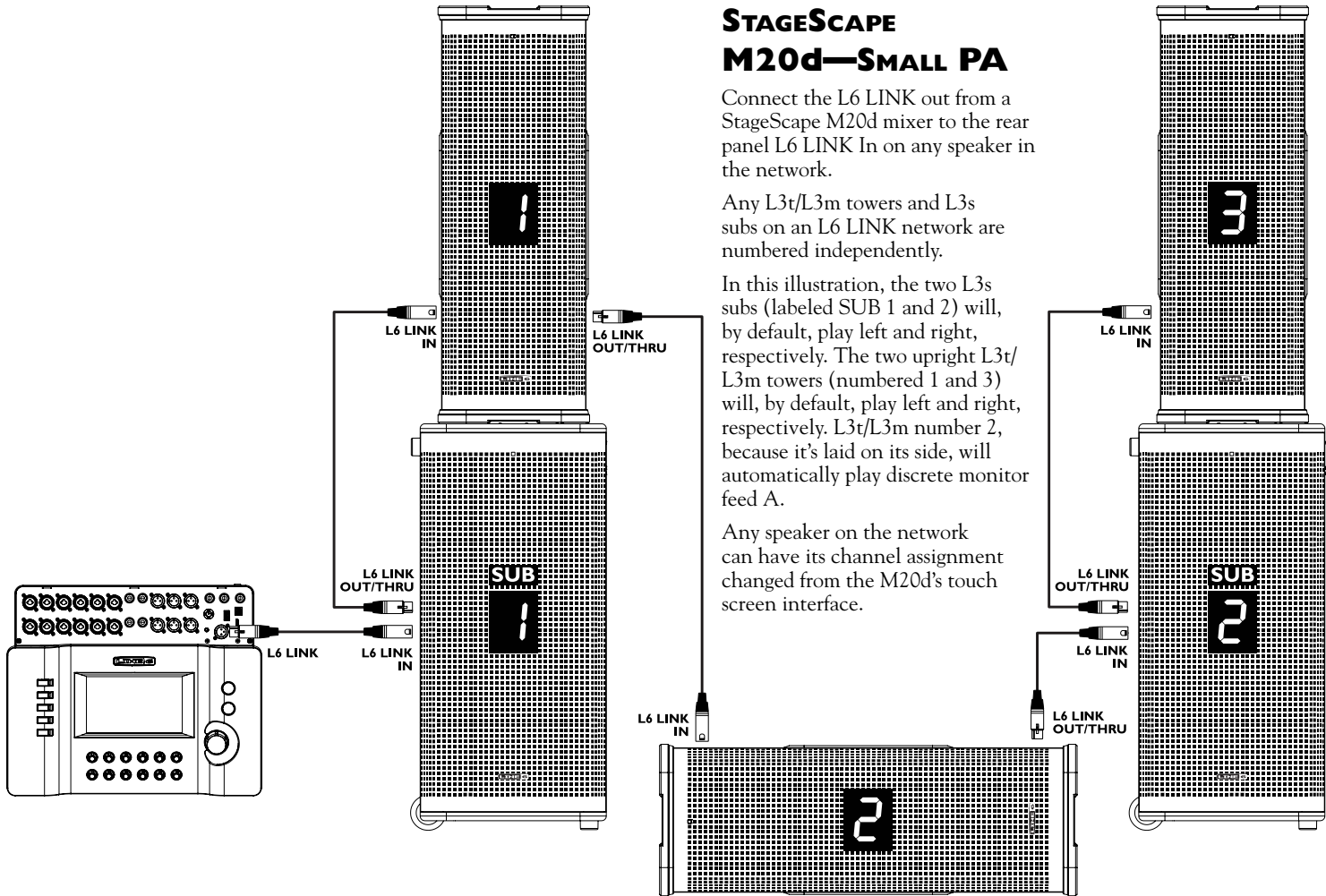

STAGESCAPE M20d—LARGE PA

In the illustration below, four L3s subs (labeled SUB 1-4) and seven L3t/L3m speakers (independently numbered 1-7) are daisy-chained from an M20d mixer. The subs and upright towers automatically configure themselves to be a powerful stereo mains system. L3t/L3m speakers on their side (numbers 3, 4, and 5) automatically configure themselves as stage monitors, and play monitor feed A, B, and C respectively.

You can also reassign any speaker from the M20d touchscreen.

