



CHOICE COLLECTION

2 0 1 3



T

hanks for picking up this catalog! MXL is a leading manufacturer of high performance audio products for professionals and recording enthusiasts around the world. Our award-winning solutions continue to astound today's top artists, engineers, professional producers and businesses that require sonic perfection on stage, in the studio and in the conference room.

We're extremely proud of our product line. From our elegant Studio Collection Series to our large line of Condenser and Ribbon microphones, MXL offers a wide assortment of microphones to fit any application or budget. Please take your time with this catalog. You'll discover an expanding product lineup that includes a full line of microphones for podcasting, field recording, web conferencing and video chats.

Whether you're a seasoned professional or just starting out, we're confident you'll find an MXL microphone that's right for you. On behalf of everyone at MXL Microphones, we appreciate and value your support and unwavering belief in our products.

Thank you!

MXL MICROPHONES

- USB VOCAL / 04
- USB CONFERENCE / 10
- MIC MATE™ SERIES / 12
- FIELD RECORDING / 14
- LIVE SERIES / 17
- STUDIO SERIES / 18
- BROADCAST / 24
- ACCESSORIES / 25

G L O S S A R Y

USB Microphones

USB microphones are simple to use -- just plug and play into any USB port and you're up and running. Designed for use with desktop or laptop computers, USB microphones are frequently used by songwriters, podcasters, broadcasters, educators and videographers.

Live Series Microphones

Our Live Series microphones are designed to vastly improve tonal clarity of stage performances. The LSM Series of microphones are built to broadcast standards and come in "warm and bright" versions.

Condenser Microphones

Condenser microphones are favorites in recording studios because of their ability to offer high sensitivity, low noise and the capability of capturing the finest nuances and details of your recording, performance, or live presentation.

Tube Microphones

Tube microphones produce a warm, rich sound that is desirable to many singers. The tube within our microphones amplifies sound and enhances harmonics for rich recordings.

Ribbon Microphones

Ribbon microphones are popular for their smooth, transparent, and natural sound. A true ribbon microphone, with its Figure-8 pattern, offers the great authentic, vintage tone desired by many recording enthusiasts.



Transmit Pure Sound Directly from the Source!

All MXL Microphones are internally wired with high quality Mogami cable. MXL chooses only the finest components, which assures you get the best quality recordings.

*Select microphones also include Mogami XLR cables!



7 in / 177 mm

TEMPO KR / TEMPO SK / TEMPO WR USB Condenser Microphone

Mobile vocal recording just got easier. The Tempo USB condenser microphone is a lightweight, easy-to-connect portable microphone. This microphone allows users to record vocals and other sounds on the go via a USB 1.1 or 2.0 connect. It also works with a wide variety of computer music programs, as well as over-the-internet communications systems such as ooVoo®, Skype®, iChat®, and Google Talk™. An integrated high-fidelity headphone output gives you the ability to monitor your recordings. Whether you are talking live through web chat or recording a vocal track on the go, the Tempo offers great flexibility.



- PC and Mac® OS compatible
 - Ideal for vocals & podcasts
- Built-in high fidelity headphone jack
 - Great for web or video chats
 - Perfect for dictation or legal depositions
- Available in three different colors

Rear View



Apple, Mac, iPad, and iChat are trademarks of Apple Inc., registered in the U.S. and other countries.

SPECS

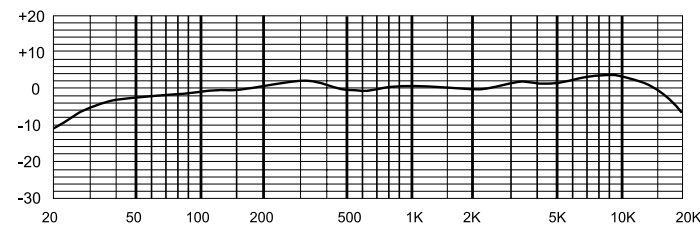
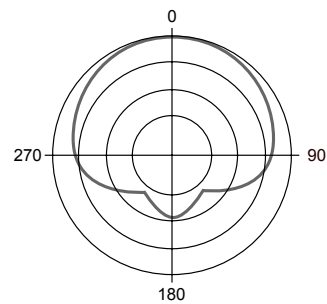

Type: USB condenser microphone
 Frequency Response: 40Hz - 18kHz
 Sampling Rate: 44.1kHz - 48kHz
 A/D Converter: 16-bit Delta Sigma with THD+N - 0.01%
 Output: 1/8" Headphone Jack/USB
 Sensitivity: -47 dB re 1 V/Pa
 Power Requirement: USB-powered
 USB Compatibility: USB 1.1 and 2.0
 OS Compatible: Windows/Mac®
 Size: 1.85" x 7.5"/47mm x 190mm
 Weight: 0.65 lbs/280g
 Metal Finish: Black/Red, Silver/Black, or White/Red

STUDIO 1 Red Dot | Desktop Recording Kit

The Studio One Red Dot is the perfect solution for providing professional quality recordings of vocals and instruments directly into your computer or compatible tablet. It is also a versatile computer audio toolkit for podcasting, Internet radio, digital music, VoIP calls, voice-over recordings and sound effects.

- Podcasting
- Home Studio Recording
- Field Recording
- Portable Studio Recording
- Voice-Over Recording
- Adding Audio to Video Programs

Works with most tablets!

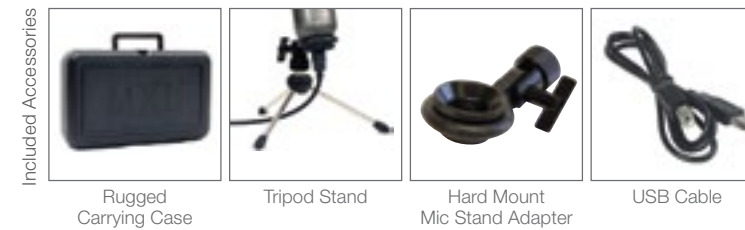

7 in / 177 mm

SPECS

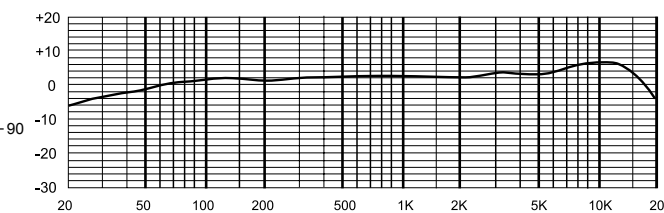
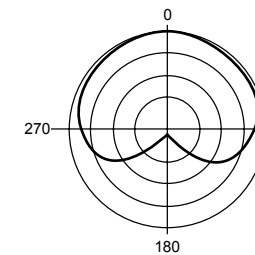

Type: USB microphone
 Frequency Response: 40Hz - 20kHz
 Sampling Rate: 44.1kHz and 48kHz
 Compatibility: USB 1.1 & 2.0
 A/D Converter: 16-bit Delta Sigma A/D Converter with THD+N - 0.01%

USB.009 | 24-bit / 96kHz USB Condenser Microphone

PATENTED The MXL USB.009 was the industry's first pro 24-bit USB microphone. This large-capsule mic turns your computer into a studio. It leaves vocals and podcasts sounding polished, with a design that brings professional quality to every recording.

- The first USB microphone to record at 24-bit / 96kHz
- Large 32mm capsule for outstanding sound quality
- Perfect for high-quality vocals and podcasts
- Headphone jack for zero-latency monitoring



8.75 in / 222 mm

SPECS

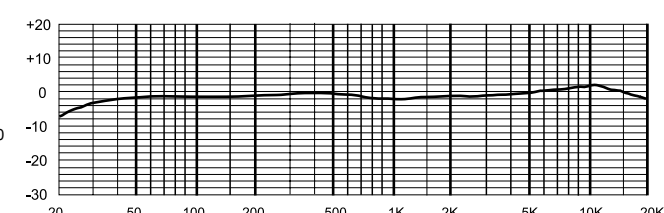
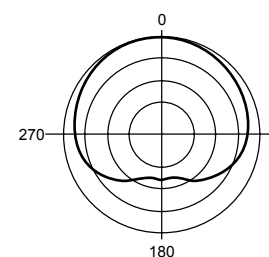

Type: 24-bit USB microphone
 Diaphragm: 6-micron, gold-sputtered
 Capsule Size: 1.26"/32mm
 Frequency Response: 20Hz - 20kHz
 Dynamic Range: 114 dB
 Compatibility: USB 1.1 & 2.0
 Bit Depths: 16 and 24
 Sample Rates: 44.1kHz, 48kHz, 96kHz



USB-77 | Classic USB Microphone

The MXL USB-77 gives vocalists, musicians, broadcasters and podcasters the look and feel of a vintage microphone with all the conveniences of USB technology. Record vocals, instruments and conduct interviews in style while experiencing studio-level sound quality and zero-latency direct monitoring.

Included Accessories



Aluminum Flight Case



Desktop Stand



USB Cable

- USB condenser mic that gives vocals a crisp sound
- Headphone jack for zero-latency monitoring
- CD/DVD-quality recordings that sound professional
- Distinctive design and performance of a classic microphone

SPECS

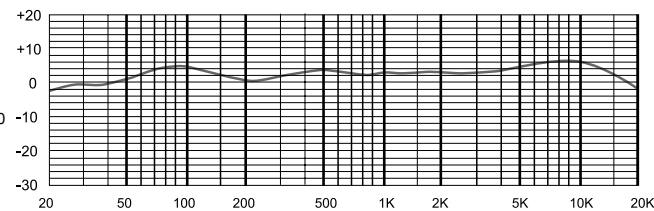
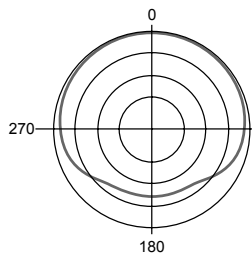

Type: USB microphone
 Diaphragm: Gold-sputtered
 Capsule Size: 1.26"/32mm
 Polar Pattern: Cardioid
 Frequency Response: 20Hz - 20kHz
 S/N Ratio: 89 dB
 A/D Converter: 16-bit Delta Sigma

Power Requirement: Bus-powered
 Compatibility: USB 1.1 and 2.0
 Compatible OS: Mac® (OS X),

Windows (XP/Vista), Windows 7
 Size: 8.75" x 4.5"/222mm x 114mm
 Weight: 1.85 lbs/839g
 Metal Finish: Black and Chrome

STUDIO 24 | 24-bit USB Microphone

The MXL Studio 24 USB puts a production studio into your computer. It's the perfect all-purpose USB mic for high-fidelity, 24-bit recordings. Plug it into your computer, load up your free recording software and start up the interface. It's all you need to record like a pro.

- USB mic that delivers high-fidelity, 24-bit recordings
- Headphone jack for zero-latency monitoring
- Downloadable interface for fine-tuning like an engineer
- Packaged with a travel case, windscreen and mic stand



Controls



Included Accessories: Carrying Case, Desktop Stand, Hard Mount Mic Stand Adapter, USB Cable

SPECS

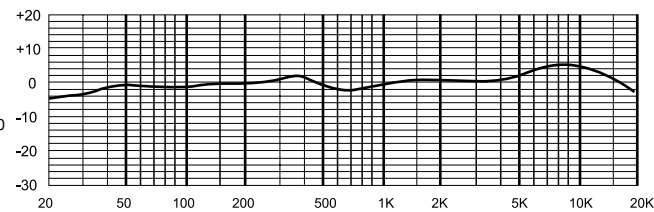
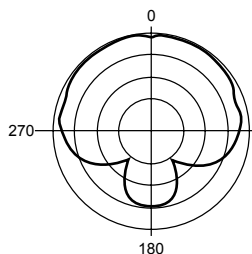

Type: 24-bit USB microphone
 Diaphragm: Gold-sputtered
 Capsule: 0.87"/22mm
 Polar Pattern: Cardioid
 Frequency Response: 20Hz - 20kHz
 High Pass Filter Settings: 120Hz, 235Hz, 465Hz
 Power Requirement: USB bus-powered
 Supported Bit Depths and Sample Rates: 24-Bit, 48kHz; 24-Bit, 44.1kHz; 16-Bit, 48kHz; 16-Bit, 44.1kHz
 GUI is Windows (XP/Vista/7) and Mac® 10.5/10.6 compatible

USB.008 | USB Condenser Microphone

The MXL USB.008 is instant studio mix. This USB condenser microphone has a sound that's the perfect blend: one part smoothness, one part clarity. Pair the mic with vocals or instruments and serve professional-sounding results no matter the style of music, broadcasts or podcasts.

- Large 32mm capsule for outstanding sound quality
- USB condenser mic that's great for all applications
- Excellent mix of smoothness and clarity
- CD/DVD-quality recordings that sound professional
- Compatible with any computer

Included Accessories



Carrying Case



Desktop Tripod Stand



Hard Mount Mic Stand Adapter



USB Cable

SPECS

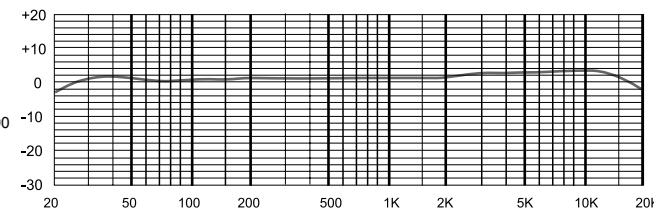
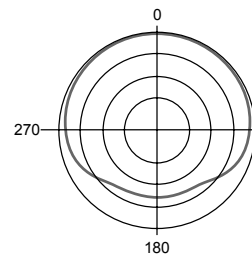

Type: USB microphone
 Capsule Size: 1.26"/32mm
 Diaphragm: Gold-sputtered
 Frequency Response: 20Hz - 20kHz
 Sampling Rate: 44.1kHz and 48kHz
 Compatible: USB 1.1 & 2.0
 A/D Converter: 16-bit Delta Sigma with THD+N = 0.01%

USB.007 | Stereo USB Condenser Microphone

The MXL USB.007 brings outstanding stereo sound to every recording. This all-purpose USB condenser microphone delivers professional-sounding results. It enhances both vocals and instruments, for all kinds of music, broadcasts and podcasts. Just plug it into your PC or Mac® and go.

- USB stereo condenser mic for all applications
- Dual-capsule design for outstanding stereo sound
- Excellent mix of smoothness and clarity
- CD/DVD-quality recordings that sound professional
- Compatible with any computer

Included Accessories



Carrying Case



Desktop Tripod Stand



Hard Mount Mic Stand Adapter



USB Cable

SPECS

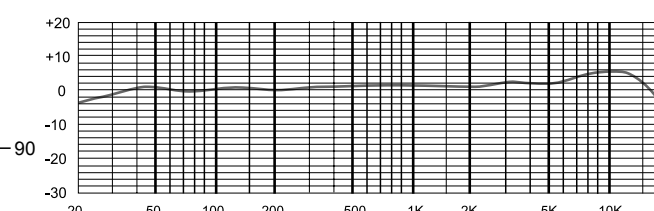
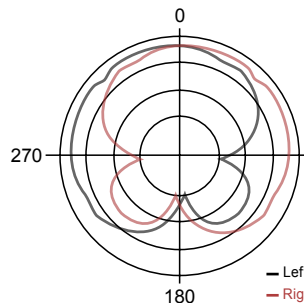

Type: USB stereo microphone
 Capsules: Two 0.87"/22mm capsules in a 90 degree X/Y configuration
 Diaphragm: 6-micron, gold-sputtered diaphragm
 Frequency Response: 20Hz - 20kHz
 Sampling Rate: 44.1kHz and 48kHz
 Compatibility: USB 1.1 and 2.0
 A/D Converter: 16-bit Delta Sigma with THD+N = 0.01%

TRIO | USB Condenser Microphone

The MXL Trio is a compact USB condenser microphone that is perfect for a variety of computing needs. The small size of the TRIO makes it ideal for the podcaster on the go, thanks to its rugged metal construction. The smooth, clear sound of vocals is faithfully captured by the TRIO. It is the perfect solution for a wide variety of popular voice chat services that are now available to consumers.

Included Accessories



Desktop Tripod Stand



Hard Mount Mic Stand Adapter



USB Cable

- 1/8" low latency headphone output
- High quality Delta Sigma A/D converter
- Plug and Play compatibility for PC and Mac® OS

Apple, Mac, iPad, and iChat are trademarks of Apple Inc., registered in the U.S. and other countries.

SPECS

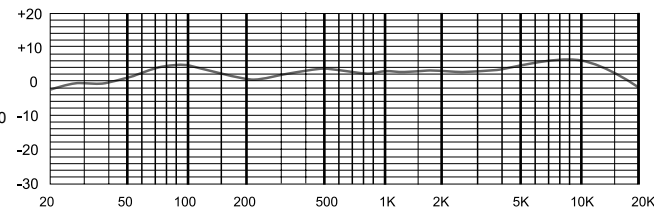
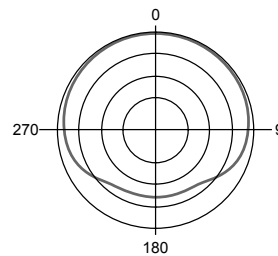

Type: USB Condenser Microphone
 Power: USB powered
 Frequency Response: 40Hz - 18kHz
 Sampling Rate: 44.1kHz - 48kHz
 USB compatibility: USB 1.1 and 2.0
 A/D converter: 16-bit Delta Sigma with THD+N - 0.01%
 Output: 1/8" Headphone Jack/USB
 Sensitivity: -47 dB re 1 V/Pa
 Metal Finish: Black

8.75 in / 222 mm

USB.006 | USB Cardioid Condenser Microphone



The MXL USB.006 Cardioid Condenser Microphone has an extremely smooth, natural sound typical of what you'd hear on a professionally produced CD or radio show. Completely plug and play, the MXL USB.006 doesn't skimp on quality with a gold-sputtered diaphragm and 20Hz - 20kHz frequency response. It even has a 3-position, switchable attenuation pad that makes it easy to configure.

- USB mic that adds polish to the spoken word
- Ideal for broadcasts, podcasts and narrations
- CD/DVD-quality recordings that sound professional
- No extra software drivers or studio equipment needed
- Compatible with any computer

Included Accessories



Vinyl Pouch



Windscreens



USB Cable



Hard Mount Mic Stand Adapter



Desktop Tripod Stand

SPECS

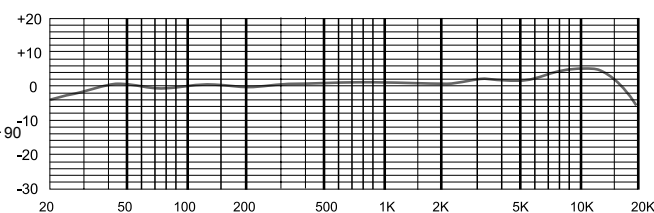
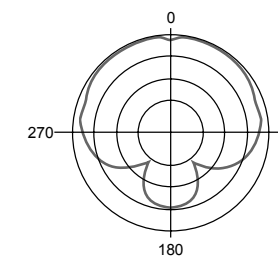

Type: USB microphone
 Diaphragm: Gold-sputtered
 Capsule Size: 0.87"/22mm
 Frequency Response: 20Hz - 20kHz
 Sampling Rate: 44.1kHz and 48kHz
 Compatibility: USB 1.1 & 2.0
 A/D converter: 16-bit Delta Sigma with THD+ = 0.01%

7 in / 177 mm

Apple, Mac, iPad, and iChat are trademarks of Apple Inc., registered in the U.S. and other countries.

ACOUSTICA MVS | USB Studio Vocal Microphone



MXL Microphones and Acoustica have teamed up to offer the Mixcraft 6 Vocal Studio, an integrated professional recording system that captures high quality performance in an easy-to-use, computer-based recording studio.

The Acoustica MVS USB Microphone is custom-designed by MXL Microphones for Mixcraft 6 Vocal Studio. This 16-bit USB recording microphone comes loaded with many of the same features as MXL's high performance studio microphones. The MVS Microphone has a wide frequency response to capture vocals and instruments with impressive clarity. The cardioid polar pattern makes it simple to target the source of sound and minimize periphery noise. The MVS Microphone transforms any computer into a recording studio - simply plug the microphone into the USB input. Record at home, in the studio or on the go with the Mixcraft 6 Vocal Studio including the Acoustica MVS USB Microphone by MXL.



- USB Condenser Microphone
- Included Exclusively with Mixcraft 6 Vocal Studio.
- Clean, transparent sound
- Ideal for recording vocals for compositions and videos made in Mixcraft

Included Accessories



Desktop Stand



Hard Mount Mic Stand Adapter



USB Cable



- Record and create an unlimited number of audio and MIDI tracks.
- Arrange and score video files, adding transitions, visual effects, music, sound effects, and voice-overs with ease.
- Includes over 6000 professionally produced music loops and sound effects in a wide variety of popular styles, from dubstep to country to heavy metal.
- Includes 11 virtual instruments, ranging from modeled vintage synthesizers to high quality sampled acoustic instruments, including an inspiring collection of studio-quality acoustic and electric drums.
- Includes 25 high quality effects, ranging from studio standards such as reverb, chorus and delay, to ultra-realistic guitar amp simulators, vintage tube EQ, pitch correction, multi-band compression, and more.
- Powerful, professional features include ReWire hosting, multi-take loop recording, time stretching and pitch shifting, support for unlimited hardware inputs and outputs, support for multi-channel VSTis, and much more.

SPECS

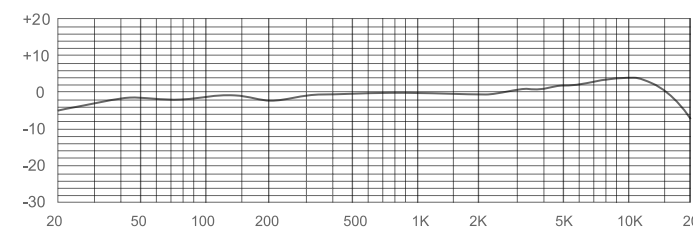
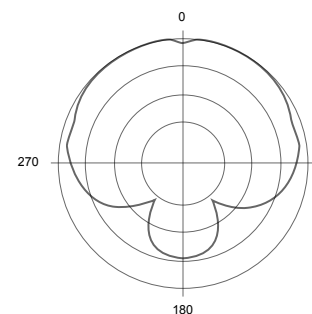

Type: USB Condenser Microphone
 Diaphragm: 6 micron gold sputtered
 Bit Depth: 16-bit
 Sampling Rates: 44.1kHz and 48 kHz
 Signal to Noise Ratio: 84dB
 Polar Pattern: Cardioid
 Frequency Response: 20 Hz - 20kHz
 Size: 60mm x 130mm / 2.36 in. x 5.11 in.
 Weight: 16 oz/1 lb
 Metal Finish: Black

Having top quality, reliable communication tools is crucial for effective business. Web conferencing software provides a means to connect, engage and increase productivity for businesses of all sizes, while reducing money on travel and time to make decisions. Today, thanks to improvements in software and technology, video conferencing solutions offer clear, crisp video images and high sound quality. Organizations looking to deliver the best in tone, definition, and coverage can enhance their audio experience with MXL USB microphones.



Enhance Your Video Chat & Web Conferencing with MXL USB Gooseneck Microphones

AC-400 | Gooseneck Microphone

The MXL AC-400 brings superior sound quality to Web conferencing. This USB gooseneck microphone has a stereo headphone input and an individual mute button. It's great for private conversations and has a flexible 15" gooseneck that's easy to adjust to the perfect position. Connect AC-40EXT extension mics for up to three participants, and you'll keep the sound quality high for everyone.

- USB gooseneck mic for Web conferencing
- Flexible 15" gooseneck that's easy to adjust
- Excellent for offices and conference rooms
- Mute button for private conversations
- Easy to connect up to three AC-40EXT mics

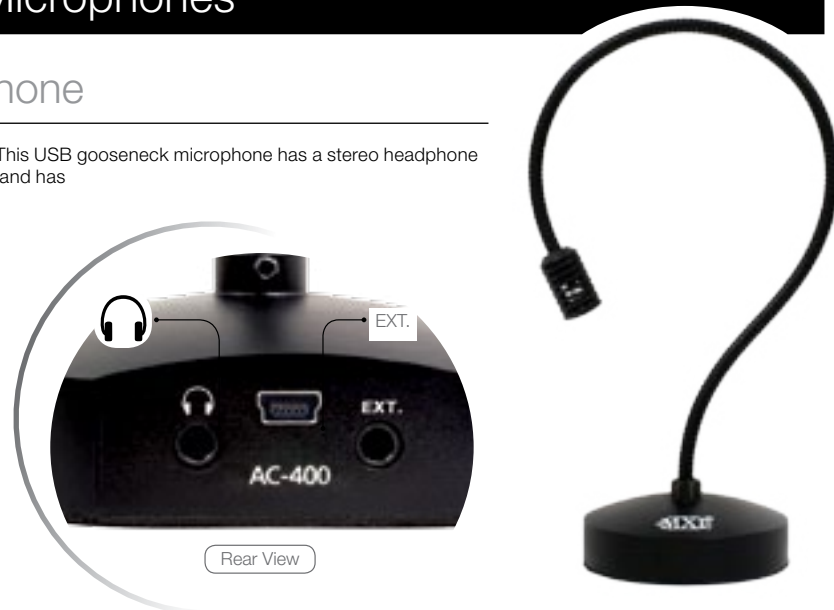

AC-40EXT | Gooseneck Extension

The MXL AC-40EXT brings groups together for high-quality Web conferencing. This USB gooseneck extension microphone has a stereo headphone plug and an individual mute button, so it's great for private conversations. The flexible 15" gooseneck is easy to adjust to the perfect position. Connect an extension mic for each participant, and you'll keep the sound quality high for everyone.

- USB gooseneck extension mic for Web conferencing
- Flexible 15" gooseneck that's easy to adjust
- Individual mute button for private conversations
- Simple connection for up to four people on individual mics
- Easy to use with AC-400 or AC-406 (required)

STURDY METAL CONSTRUCTION!



Add the optional AC-40EXT gooseneck extension microphone to the AC-400 mic to extend the range of your conference!

AC-404 | USB Conference Microphone

The MXL AC-404 turns any space into a conference room. This USB boundary microphone brings outstanding sound quality to web conferencing, even in a noisy room. It has 180-degree coverage for superior sound over a wide range, so it's perfect for conferences with several people. Includes an audio jack for connecting headphones or speakers, so it can give any level of privacy.



- High-quality USB boundary mic for web conferencing or instrument recording
- Excellent for offices and conference rooms
- Standard jack for headphones or speakers
- 180-degree coverage for great sound over a wide range
- Compatible with any computer

SPECS

Type: USB boundary microphone
 Capsule: 3 capsule boundary design with 180-degree coverage
 Frequency Response: 40Hz - 16kHz
 Sampling Rate: 44.1kHz - 48kHz
 USB Compatibility: USB 1.1 and 2.0
 A/D Converter: 16-bit Delta Sigma with THD+N - 0.01%



AC-406 | USB Desktop Communicator

The MXL AC-406 adds extra flexibility to Web conferencing. This USB boundary speakerphone delivers outstanding sound and clarity, and it doubles as a high-quality speaker. It has 180-degree coverage for superior sound over a wide range, so you're free to walk and talk without a headset. An integrated mute button assists with private conversations.



- USB boundary speakerphone for Web conferencing
- High-quality replacement for bulky computer speakers
- 180-degree coverage for great sound over a wide range
- Individual mute button for private conversations
- Compatible with any computer

High fidelity web conferencing featuring advanced boundary microphone technology

SPECS

Type: USB conferencing device
 Capsule: 3 capsule boundary design with 180-degree coverage
 Speaker: 4 Ohm 5W
 Power: USB
 Frequency Response: 40Hz - 16kHz
 Sampling Rate: 44.1kHz - 48kHz
 Compatibility: USB 1.1 and 2.0



Rear View

AC-406 USB DESKTOP COMMUNICATOR WORKS WITH OPTIONAL GOOSENECK EXTENSION

Apple, Mac, iPad, and iChat are trademarks of Apple Inc., registered in the U.S. and other countries.

MIC MATE™ CLASSIC | XLR-to-USB Adapter

Mic Mate™ Classic converts any existing condenser microphone to USB, providing 48V phantom power. Complete with a studio-quality USB microphone preamp, fully balanced low-noise analog front end, and 3-position analog gain switch, the Mic Mate™ Classic's compact size is perfect for travel.



- Converts any existing condenser microphone to USB
- Plug and record with your favorite software
- No special drivers required
- Travel size body in champagne
- Free MXL USB Recorder Software for instant 2-Track recording
- PC and Mac® compatible

MIC MATE™ PRO | XLR-to-USB Adapter with Gain

This incredibly versatile and compact universal interface facilitates the connection of condenser microphones directly to your computer via USB, effectively converting your existing microphone into a USB microphone. Instantly start recording without any special driver installations. To further simplify use, the MXL Mic Mate™ Pro handles microphone gain and headphone volume adjustments with low profile rotary knobs, while the built-in headphone jack allows for zero-latency direct monitoring. Studio-quality computer recording is now within the reach of every aspiring musician and recording enthusiast.



➤ SUPPLIES PHANTOM POWER

- Excellent for overdubbing or playing along with music
- Plug and record with your favorite software
- Features gain and headphone controls
- Works with virtually all microphones
- Instantly start recording without any special driver installations

MIC MATE™ LINE LEVEL | XLR-to-USB Adapter

Feed line level sources to your computer with the Mic Mate™ Line Level adapter and enjoy studio-quality results. This pocket-sized device features a 16-bit Delta Sigma A/D converter with a sampling rate of 44.1kHz and 48.0kHz, three selectable gain levels (+10 dB, +4 dB and -10 dB), and a fully balanced low-noise analog front end.



- The no-hassle solution for gathering news feeds, transferring audio from video, and archiving
- Compact travel size with durable die cast metal construction
- +10 dB, +4 dB, and -10 dB settings
- Fully balanced low noise analog front-end
- Single channel 16-bit Delta Sigma A/D Converter
- Sampling Rate - 44.1kHz and 48.0kHz
- Frequency Response - 20Hz - 20kHz
- Three Position Analog Gain Control
- Bus-powered
- No special drivers required
- Plug and record with your favorite software
- USB 1.1 and 2.0 Compatible
- Compact Travel Size: 0.85" OD 5.75" Long
- Free MXL USB Recorder Software for instant 2-Track recording
- PC and Mac® compatible

MIC MATE™ DYNAMIC | XLR-to-USB Adapter

This studio-quality USB dynamic microphone / preamp facilitates the connection of dynamic microphones directly to a computer via USB. It effectively converts any dynamic microphone into a USB microphone. To further simplify using the microphone with a computer, the MXL Mic Mate™ Dynamic handles analog gain adjustment settings via a built-in three-position attenuation switch.



- Studio-quality USB dynamic microphone adapter / preamp
- Adapts any existing dynamic microphone to USB
- Perfect companion for SM-57/58, RE50, 635N/DB, LSM-5GR and LSM-7GN
- Easy Plug and Record -- no special drivers required!
- Fully balanced low noise analog front-end
- Three position analog gain control
- Compact travel size with heavy duty diecast metal construction

MIC MATE™ USB MINI MIXER | Kit

The Mic Mate™ USB Mini Mixer Kit puts the power of professional listening and recording in the palm of your hand! This portable all-in-one kit is perfect for musicians, composers, podcasters and educators who want quality sound recordings without having to buy or lug bulky, expensive audio gear. Simply plug the Mic Mate™ Mini Mixer into your PC or Mac®, listen or record with your favorite software and experience the difference a professionally-mixed recording can make.



Record, listen and mix like a pro!

Add up to 4 dynamic microphones to your desktop or laptop computer



Included Accessories



Carrying Case



Hard Mount Mic Stand Adapter



USB Cable



4 XLR-to-mini Mic Cables



Desktop Tripod Stand

- Record, listen and mix at home, in the studio, or on the road
- Perfect for group rehearsals, video voice-overs, podcasting and group interviews
- Works with your favorite desktop audio recording software
- PC and Mac® compatible

Apple, Mac, iPad, and iChat are trademarks of Apple Inc., registered in the U.S. and other countries.



ON THE SET WITH MXL

FR-500WK | Professional Portable Wireless Audio System

The FR-500WK Professional Portable Wireless Audio System is designed for videographers conducting interviews or recording onscreen talent via an easily concealed lavalier microphone. The lavalier mic is used with the transmitter while the receiver can be mounted directly onto the hot shoe mount of a DSLR camera. The FR-500WK interview kit provides high sound quality in a compact, portable design, and it has a long transmission range – perfect for field work. The FR-500WK has a wide frequency response for accurate sound reproduction. The kit is comprised of the FR-500WT Transmitter and the FR-500WR Receiver.

The FR-500WT Transmitter has a built-in microphone, 1/8" (3.5 mm) mic jack, and mono line in. A discreet omni lavalier microphone is included. Alternatively, the microphone input can be used with a 1/8" (3.5 mm) to XLR male cable and ¼" adapter are included to connect the receiver to mixers and other pro audio gear. Additionally, the receiver can be used with headphones and a recording device.

The FR-500WR Receiver has a built-in speaker, 1/8" (3.5 mm) headphone jack, and line out. A hot shoe adapter and a 1/8" to 1/8" cable are included to mount the receiver on top of a DSLR camera. A 1/8" (3.5 mm) to XLR male cable and ¼" adapter are included to connect the receiver to mixers and other pro audio gear. Additionally, the receiver can be used with headphones and a recording device.

- Ultra High Frequency from 566.25 - 589.75
- 64 channel selections. (4 groups x 16 channels)
- Easy access/change group and channel dials
- LED lights indicate different channel groups.
- Long transmission range: up to 280m in line of sight
- Long battery life (2x AA): up to 10 hrs
- Wide frequency response from 40Hz to 18KHz

Controls: Power On/Off, Channel Selection, Volume Control, Group Selection, Boost
 Battery: Each unit requires 2x AA (not included)
 Battery Life: 10 hours typical
 Dimensions: 62mm(W) x 20mm(D) x 97mm(H)



The transmitter works with the included lavalier microphone or an optional dynamic microphone.



FR-300 | 10" Shotgun Microphone

The MXL FR-300 phantom powered shotgun microphone allows videographers to reach out to subjects for clear, high quality recording. The MXL FR-300 can also be used for general video recordings like weddings as well as for Foley work, interviews, and other settings when the distance to the subject is farther than the built-in camera mic will allow.



- Clear, high quality recordings
- Great for weddings, Foley work, and interviews
- Point and record your audio
- Used to improve audio recordings for videography

FR-301 | 16.5" Super-Cardioid Shotgun Microphone

Designed for video production and broadcast professionals, the MXL FR-301 phantom powered shotgun microphone offers clear, accurate recordings and exceptional side rejection. Measuring over 16 inches, the FR-301's narrow pattern allows you to single out your subject when there is unwanted background noise the built-in camera mic can't handle. This mic can also be used for general video recordings like weddings as well as for Foley work and interviews.

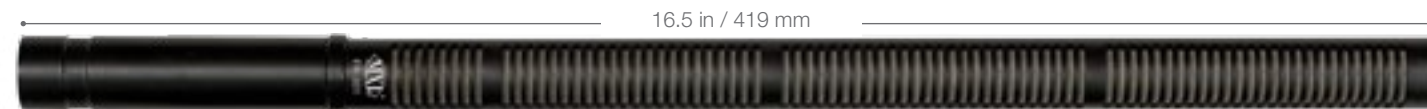

- Phantom Powered
- Clear, accurate recordings
- Designed for video production and broadcast applications

FR-330M | 6" Shotgun Microphone



RoHS compliant

When the subject is farther than a built-in camera mic will effectively record, you'll need a good shotgun mic like the FR-330M. Measuring 6 inches in length, the FR-330M offers clear, high quality recordings and is perfect for videographers who want a shorter mic mounted on camera.

- Perfect for digital and analog videographers
- Built-in XLR cable
- Small size is ideal for DSLR camera use

FR-304 | 14.5" Shotgun Microphone

The MXL FR-304 Shotgun Microphone is a great choice for the consumer, semi-pro or professional videographer on the go. The FR-304 includes a FET preamp and can be used in a variety of situations either under its own power or via a camera. It is powered with a standard AA battery with 160+ hour life.

Great for DSL Cameras

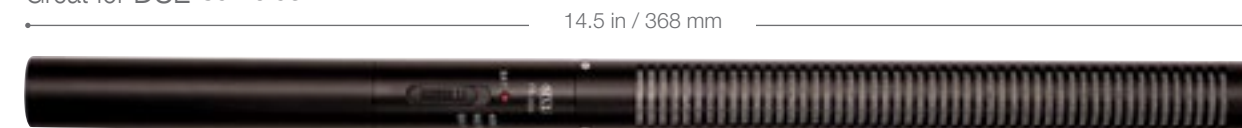

- Great choice for the consumer, semi-pro or professional videographer on the go
- Self-powered via AA battery or camera supplied power

FR-310 | Hot Shoe Shotgun Microphone



The MXL FR-310 video mic delivers sound that's as focused as the video. Mount it onto your camcorder or DSLR camera, and you'll cut to tighter, cleaner sound recordings. The FR-310 shuts out sound from the sides and back with a pickup pattern that targets sound in front of the camera. Three gain settings pull in the right amount of sound in close-up or long shot situations, while a bass roll-off switch leaves low-frequency noise on the cutting-room floor. The integrated windscreens helps block wind noise, which aids in keeping your sound in the picture.

Included Accessories



Aluminum Flight Case

- Three-position gain switch
- Bass roll-off (high-pass filter)
- Standard hot shoe mount
- Up to 500 hours per AAA battery
- Integrated foam windscreens



RoHS compliant

Transducer: Electret Condenser
 Polar Pattern: Supercardioid
 Frequency Response: 40Hz - 20kHz
 Output Impedance: 250 Ohm
 Power Requirements: 1.5V AAA Battery
 Low Frequency Roll-Off: -6 dB/octave @150Hz
 Output Connector: 1/8"/3.5mm Mini TRS
 Gain: -5 dB, 0 dB, +5 dB
 Output Signal: Mono
 Battery Life: +500 hours
 Dimensions: 5.3" x 2.5"/35mm x 63mm
 Weight: 0.30 lbs/136g

FR-355K | Lavalier Interview Kit

The microphones in the MXL FR-355K kit were designed with high quality FET pre-amps to ensure outstanding audio quality even under the most demanding conditions. The FR-355K kit contains two different microphones that require 48V phantom power to operate. They are both supplied with foam windscreens and clips.

- Incredible flexibility for interviews
- Easy to conceal onscreen
- Clear, clean interviews for your audio/video projects



Cardioid* *Windscreens included Omni*

FR-400M | Boundary Microphone

Although it's commonly used in front of a stage to pickup concerts or theater events, the FR-400M boundary mic has a wide cardioid pattern and can be used in other applications like under the lid of a piano. The switch located on the bottom of the mic can be used to boost or cut low frequencies by 6 dB in order to balance the frequency response.

- Wide cardioid pickup pattern
- Internally wired with Mogami cable
- Ideal for stage, live performances, instrumental recordings and more!
- Bass cut/boost switch
- Includes a 10' XLR cable



FR-401M | Boundary Microphone

The MXL FR-401M boundary mic is designed to pickup multiple sources from a distance while avoiding unwanted sounds from behind the mic. Some common applications include recording interviews, live concerts, studio recording sessions, or plugging directly into a video camera to make sure you get all the audio on set.

- Great for instruments, stage, live performances, interviews, and podcasting
- Sturdy construction for years of use
- Easy podium placement
- Built-in 15' XLR cable



FR-432M | Boundary Microphone

The MXL FR-402 is a multi-purpose boundary mic with a wide pattern and low profile. You can use this mic on a number of different sources in almost any location. It's also right at home on a conference table, recording interviews, connected to a video camera for field recording or capturing audio from a concert or play.

- Three capsule array
- Includes 15' mini XLR-to-XLR cable
- Wide pattern for stage, live performance, interviews, podcasting, and concerts



Dynamic microphones have been a popular choice for professional vocal and broadcast applications for many years. Meeting the needs of today's top artists, performers and live presenters, the MXL LSM dynamic microphones are fine-tuned to the requirements of professional broadcast studios.

Ruggedly constructed with a cardioid pattern, the LSMs are the quintessential microphones for eliminating unwanted feedback and providing the performer optimal results in a live performance, small assembly or large venue setting.



LSM-5GR & 7GN | Handheld Dynamic Microphones



- Rugged construction
- Low handling noise
- Great feedback rejection
- Convenient On/Off switch

LSM-5GR / Bright

The MXL LSM-5GR is a dynamic mic for dynamic performers. It's built to enhance all types of singers and set them free on the stage. It has extremely low handling noise, so it's right at home in the hand of a singer who likes to move. It switches on and off without a sound, and it blocks feedback and other noise. All that's left is clear, crisp vocals and a thrilling performance.

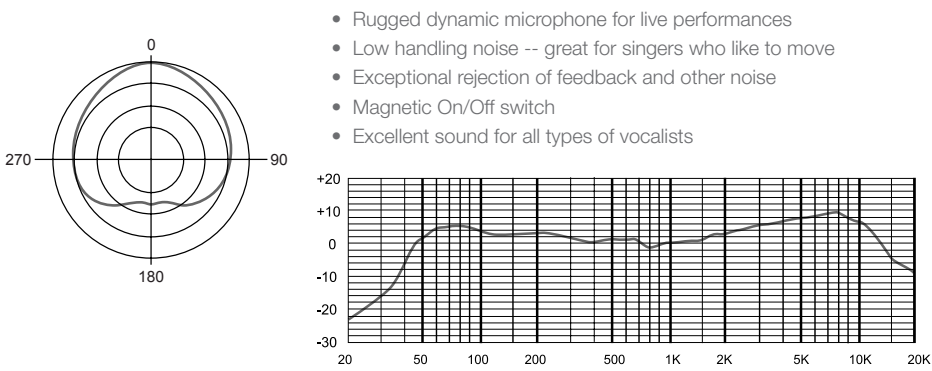

- Rugged dynamic microphone for live performances
- Low handling noise -- great for singers who like to move
- Exceptional rejection of feedback and other noise
- Magnetic On/Off switch
- Excellent sound for all types of vocalists

LSM-7GN / Warm

The MXL LSM-7GN provides a solid low-end and clear high-end frequency spectrum. It is ideal for live performances or presentations. The On/Off switch allows the mic to be turned off and left on stage while others are still performing. The LSM's cardioid patterns are ideal for eliminating unwanted feedback in live settings.

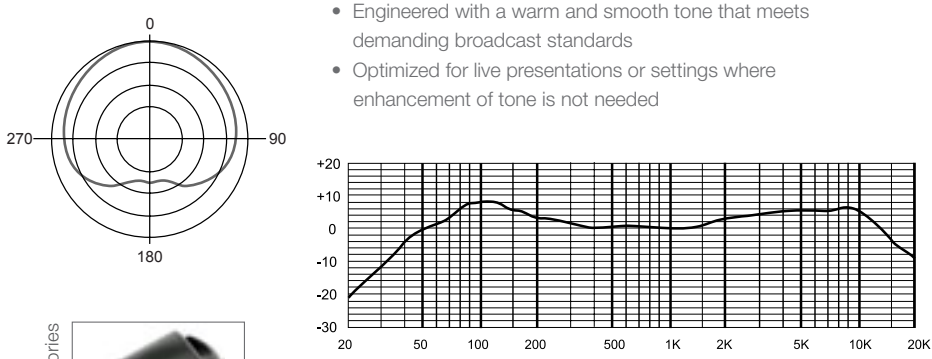

- Rugged construction
- Engineered with a warm and smooth tone that meets demanding broadcast standards
- Optimized for live presentations or settings where enhancement of tone is not needed



Type: Dynamic microphone
 Polar Pattern: Cardioid
 Frequency Response: 40Hz - 15kHz
 Sensitivity: -54dB re 1 V/Pa
 Impedance: 600 ohms
 Size: 7" x 1.93"/177mm x 49mm
 Weight: 0.65 lbs/295g

MXL 2001 | Large Diaphragm Condenser Mic

The MXL 2001 is a performer's partner. This condenser microphone follows every note and gives it a sound that melts. Sounds rich and creamy in the middle, with detail pouring from the top. It's sensitive, with a knack for finding all of a performer's nuances and making tiny highlights glow. The 2001 is perfect for a singer or acoustic guitarist who knows how to work the fine points.

Included Accessories



Hard Mount
Mic Stand Adapter

- The first MXL mic -- still a favorite among musicians
- Condenser mic that captures performers' nuances
- Perfect for vocals but also great for acoustic guitars
- FET preamp with transformer-balanced output
- Rich midrange and a detailed top end

SPECS

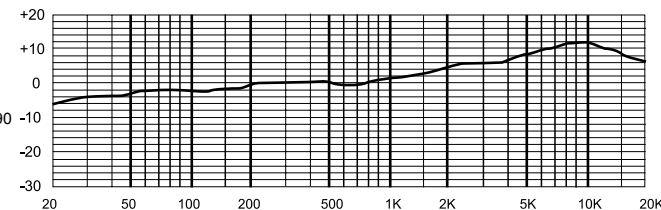
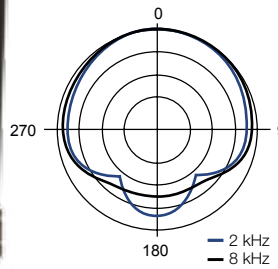

Type: Condenser pressure gradient microphone with large diaphragm capsule
 Capsule Size: 1 1/25mm
 Frequency Response: 30Hz - 20kHz
 Polar Pattern: Cardioid
 Sensitivity: 15 mV/Pa
 Output Impedance: 200 ohms
 S/N Ratio: 80 dB (Ref. 1Pa A-weighted)
 Equivalent Noise: 18 dB (A-weighted IEC 268-4)
 Max SPL for 0.5% THD: 130 dB
 Power Requirement:
 Phantom power 48V ±4V
 Current Consumption: <3.0mA
 Size: 1.97" x 7.4"/50mm x 190mm
 Weight: 1 lbs/470g
 Metal Finish: Black

7.4 in / 190 mm



MCA-SP1 | Studio Condenser Microphone

The MCA-SP1 is our most affordable studio condenser mic that provides professional results. This mic has a cardioid pickup pattern to reject off-axis noise and prevent feedback, as well as a wide frequency response and a high SPL capability. The MCA-SP1 mic uses a standard XLR connector and 48V phantom power for wide compatibility with home and professional studios.

Included Accessories



Hard Mount
Mic Stand Adapter

- Robust metal body for lasting durability
- Cardioid pickup pattern to reject off-axis noise and prevent feedback
- Delivers clear, natural results with no distortion
- Most affordable condenser microphone

SPECS

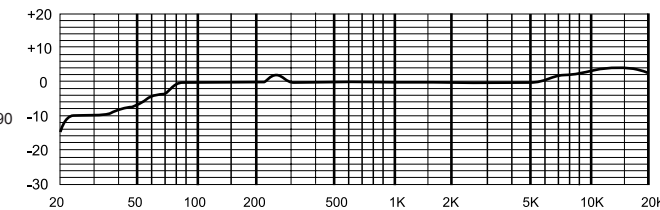
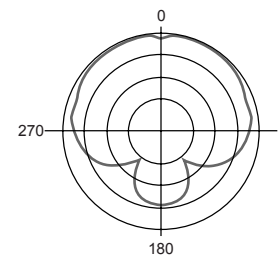

Type: Condenser pressure gradient
 Capsule Size: 0.87"/22mm
 Diaphragm:
 6 micron, gold-sputtered
 Frequency Range: 30Hz - 20kHz
 Polar Pattern: Cardioid
 Impedance: 200 ohms
 Max SPL for 0.5% THD: 135 dB
 Power Requirements:
 Phantom power 48V +/- 4V
 Size: 1.85" x 7"/47mm x 180mm
 Weight: 1.2 lbs/544g
 Metal Finish: Black

7 in / 180 mm



MXL 2008 | Studio Condenser Microphone

The MXL 2008 brings extra detail to any recording. It's a superior all-purpose mic that's made to pick up the fine points of a performance. It has an outstanding sound -- clean and clear, with touches of brilliance on every note. It turns tiny highlights into glowing rays. Use it for vocals, instruments and percussion in any style of music, and you'll get top-notch recordings.



Included Accessories



High-Isolation
Shockmount with
Carrying Case

- Versatile microphone that's excellent for all applications
- Large, sensitive 32mm capsule that captures subtle details
- Great for vocals, acoustic guitars, strings and percussion
- Transformerless FET circuitry for clean, clear recordings
- Outstanding results for all styles of music

SPECS

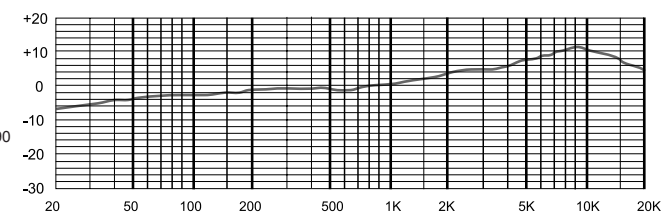
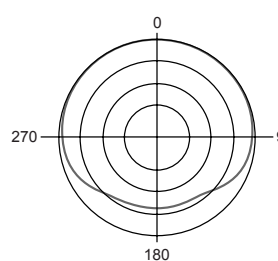

Type: Condenser pressure gradient
 Capsule Size: 1.26"/32mm
 Diaphragm: 6 micron, gold-sputtered
 Frequency Response: 30Hz - 20kHz
 Polar Pattern: Cardioid
 Sensitivity: 18mV/Pa
 Output Impedance: 150 ohms
 Equivalent Noise: 16 dB (A-weighted IEC 268-4)
 S/N Ratio: 78 dB (Ref. 1Pa A-weighted)
 Max SPL for .5% THD: 130 dB
 Power Requirements:
 Phantom power 48V ±4V
 Current Consumption: <3.0mA
 Size: 1.85" x 7.2"/47mm x 183mm
 Weight: 1.3 lbs/589.67 g
 Metal Finish: Silver

7.2 in / 183 mm



V76t | Cardioid Tube Condenser Microphone

The MXL V76T is like time travel for singers. This tube microphone gives vocals a vintage sound. It's smooth and solid in the middle, with overtones that make recordings sparkle. It's the kind of tone that makes music from the past so classic. The V76T has an upfront presence that lands in the right place in a mix, no matter which kind of music you're making.

Included Accessories



Includes high-isolation shockmount,
power supply, 7-pin power cable,
windscreen and carrying case

- Tube mic that enhances vocals with rich harmonics
- Balanced output for a smooth, solid midrange
- 12AT7 dual-triode tube that delivers vintage tone
- Great up-front presence that sits well in a mix
- Excellent for recording R&B, rock, pop and country

SPECS

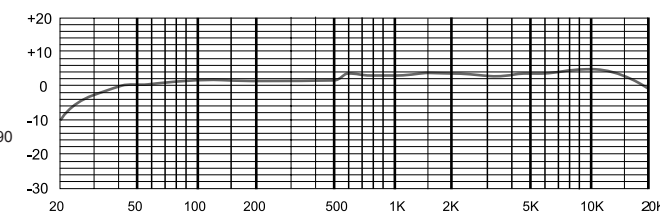
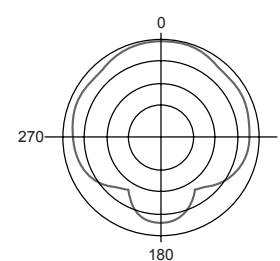

Type: Vacuum tube condenser
 Capsule Size: 1 1/25mm / 6 micron
 Frequency Range: 30Hz - 20kHz
 Polar Pattern: Cardioid
 Sensitivity: 38 MV/pa
 Impedance: 200 ohms
 Equivalent Noise: 18 dB (A-weighted IEC 268-4)
 Max SPL for .5% THD: 122 dB
 Power Requirements:
 120/240V 50/60hz
 Size: 1.85" x 7"/48mm x 180mm
 Weight: 1.15 lbs/525g
 Metal Finish: Nickel Plated

7 in / 180 mm



V67G | Large Capsule Condenser Microphone

The MXL V67G brings extra finesse to vocals. This solid-state microphone gives vocals a mellow touch, with a rich middle that makes every word pop. The warm tone leaves every note velvety. The crystal clear sound pours light onto every detail. You'll get outstanding vocals that stand out over the rest of the tracks.

Included Accessories



Hard Mount
Mic Stand Adapter



Leatherette
Pouch

- Solid-state mic that breathes warmth into vocals
- Rich midrange that matches tube microphones
- Crystal clear sound that's loaded with warmth
- Penetrating vocals that stay above the tracks
- Excellent for R&B, pop, rock and country

SPECS

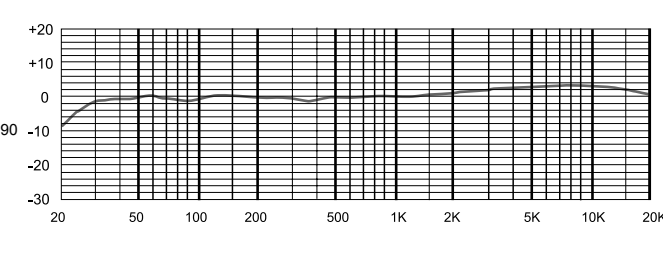
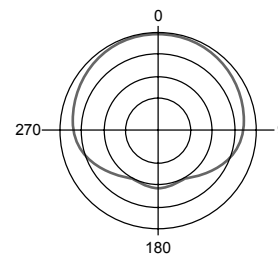

Type: Pressure gradient
32mm capsule
Diaphragm:
6 micron, gold-sputtered
Frequency Range: 30Hz - 20kHz
Polar Pattern: Cardioid
Sensitivity: 15 mv/Pa
Impedance: 200 ohms
Equivalent Noise: 20 dB
(A-weighted IEC 268-4)
S/N Ratio: 74 dB
(Ref. 1 PA A-weighted)
Max SPL for 0.5% THD: 130 dB
Power Requirements:
Phantom power 48V +/- 4V
Size: 1.8"x 7.2"/47 mm x 184 mm
Weight: 1.3 lbs/589g
Metal Finish: Green with gold grill



R150 | Ribbon Microphone

Incorporating a Figure-8 polar pattern and a 1.8-micron aluminum ribbon, the R150 offers breathtaking sound for vocal and instrument recordings. It is an excellent microphone for broadcast applications. The R150 also performs brilliantly on acoustic instruments, strings, and horns. It offers high SPL capability, outstanding side rejection and precise directivity.

Included Accessories



Shockmount



Microfiber
Cleaning Cloth

- Ribbon microphone that delivers a dark, warm tone
- Mellow sound with a rich midrange and a rolled-off top end
- Figure-8 polar pattern that captures instruments and room sound
- High SPL capability -- ideal for electric guitars, horns and percussion
- Also great for electric guitar cabinets, acoustic guitars and strings

SPECS

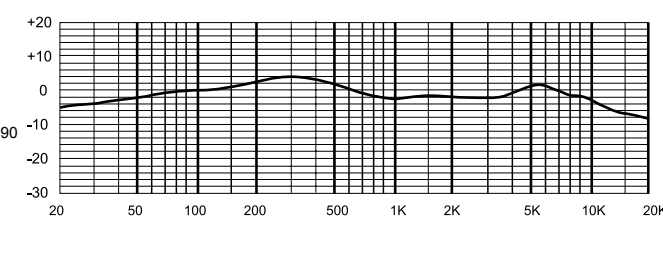
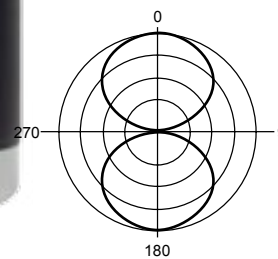

Type: Ribbon velocity microphone
Ribbon Element:
1.8-micron aluminum ribbon
Ribbon Length: 1.8"/47mm
Frequency Range: 20Hz - 17kHz
Polar Pattern: Figure-8
Sensitivity: -56 dB (0 dB=1V/Pa)
Impedance: 250 ohms
Rated Load Impedance:
>1500 Ohms
Max SPL for 0.1% THD:
>130 dB @ 1 kHz
Size: 1.85" x 6.75"/47mm x 171mm
Weight: 0.85 lbs/400g
Metal Finish: Purple and chrome



CR-24 | Studio Condenser Kit

A unique addition to the MXL microphone line, the MXL Cr-24 Black Chrome Vocal & Instrument Microphone Kit is destined to become an artist favorite. This stunning vocal and instrument duo is handcrafted with a finish that dazzles like chrome, but with a black sheen like no other microphone out there. The MXL Cr-24 Kit captures the fine nuances of vocals and instruments and will exceed your wildest expectations on clarity, presence and detail.

- Vocal and Instrument microphone kit with beautiful black chrome finish
- Easy-to-use and ready to record on stage or in studio
- FET preamp delivers a smooth and even response
- Switch selectable bass roll-off and -10 dB pad for recording flexibility (Cr-24)
- High SPL handles all recording applications
- 3-year warranty

Included Accessories



Aluminum
Flight Case



Large Shockmount

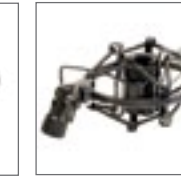

Small Shockmount



2 Leatherette
Pouches



2 Windscreens



Microfiber
Cleaning Cloth



Handling Gloves



MXL CR-24 / Large Diaphragm Condenser Microphone

Type: Pressure gradient condenser mic
Diaphragm: 3 micron gold-sputtered
Frequency Response: 20 Hz - 20 kHz
Polar Pattern: Cardioid
Sensitivity: -42.9 dB re 1 V/Pa
Impedance: 200 ohms
Equivalent Noise Level: 11 dB (A-weighted IEC 651)
Max SPL for 0.5% THD: 152 dB SPL
Power Requirements: Phantom Power 48V (+/- 4V)
Current Consumption: 6.6mA
Weight: 1 lbs / 453.59g
Size: 50mm x 190mm/1.97 in. x 7.48 in.
Metal Finish: Black chrome

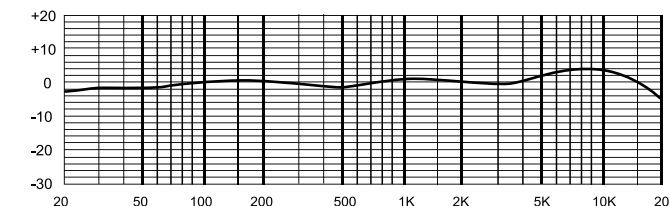
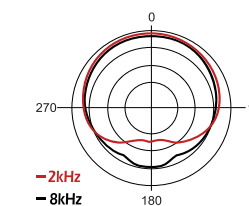
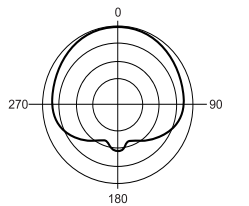
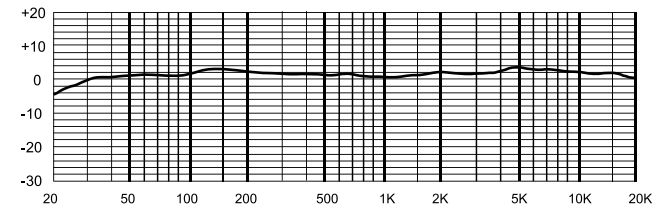

Type: Pressure gradient condenser mic
Diaphragm: 6-micron gold-sputtered
Frequency Range: 30Hz-20kHz
Polar pattern: Cardioid
Sensitivity: 10 mv/Pa
Impedance: 200 ohms
S/N Ratio: 80 dB (Ref. 1Pa A-weighted)
Equivalent noise: 18 dB (A-weighted IEC 268-4)
Max SPL for .5% THD: 134 dB SPL
Power Requirements: 48V Phantom Power (+/- 4V)
Current Consumption: <3.0mA
Size: 22mm x 135mm/0.87 in. x 5.31 in.
Weight: 130g/0.29lbs
Metal Finish: Black chrome

MXL CR-24p



550 / 551R | Recording Ensemble



This all-in-one Recording Ensemble delivers outstanding performance for both vocals and instruments. Ideal for quality-oriented but budget-minded musicians, the MXL 550/551R ensemble includes the MXL 550 and MXL 551. The MXL 550 is a robust vocal condenser microphone with exceptional clarity and tonal quality. The MXL 551 instrument microphone provides the dynamic range needed for acoustic guitars, drums, high-hat cymbals, pianos, percussion, stringed instruments and more.

- Microphone pair that can cover all recording needs
- Perfect to use together -- one for vocals, one for instruments
- Fine-tuned to deliver extra clarity and detail
- FET preamp with balanced output and low noise
- Distinctive design with a striking red body



Included Accessories



Rugged Carrying Case



Hard Mount Mic Stand Adapter



Hard Mount Mic Stand Adapter

MXL 550



6.6 in / 170 mm

Type: Pressure gradient condenser microphone
 Frequency Range: 30Hz - 20kHz
 Sensitivity: 15mV/Pa
 Impedance: 200 ohms
 S/N Ratio: 80 dB (Ref. 1Pa A-weighted)
 Equivalent Noise Level: 20 dB (A-weighted IEC 268-4)
 Max SPL for 0.5% THD: 130 dB
 Power Requirements: 48V Phantom power (+/- 4V)
 Current Consumption: <3.0mA
 Size: 1.8" x 6.6"/47mm x 170mm
 Weight: 0.8 lbs/362g
 Metal Finish: Red with chrome grill

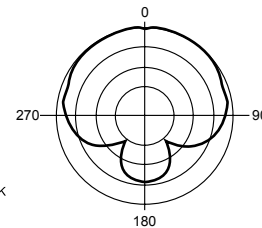
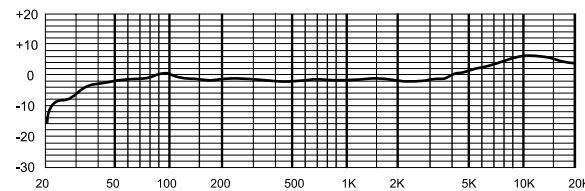

MXL 551R



5.24 in / 133 mm

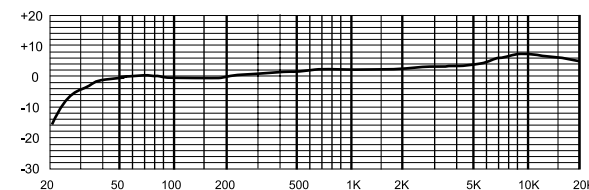
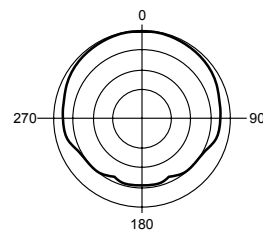

Type: Pressure gradient condenser microphone
 Frequency Range: 30 Hz - 20 kHz
 Polar Pattern: Cardioid
 Sensitivity: 15mV/Pa
 Impedance: 110 ohms
 S/N Ratio: 78 dB (Ref. 1Pa A-weighted)
 Equivalent Noise Level: 20 dB (A-weighted IEC 268-4)
 Max SPL for 0.5% THD: 137 dB
 Power Requirements: 48V Phantom power (+/- 4V)
 Current Consumption: <3.0mA
 Size: 0.86" x 5.24"/22mm x 133mm
 Weight: 0.2 lbs/90g
 Metal Finish: Red with chrome grill

603 Pair | Instrument Microphone Pair

PATENTED

Designed with professional and working musicians in mind, the 603 Instrument Microphone Pair delivers the natural acoustic properties you need for overhead drums, piano, string instruments, and more. Designed with a gold-sputtered, 6 micron gold diaphragm, the 603 Pair is ideal for recording your orchestra, opera, stage show, and more.



Included Accessories

High-Isolation Shockmount

Aluminum Flight Case

- Ideal for recording orchestras, operas or stage shows
- Open, transparent sound
- Easy to use and ready to record on stage or in a studio
- Sleek nickel plated body design



5.2 in / 133 mm

SPECS

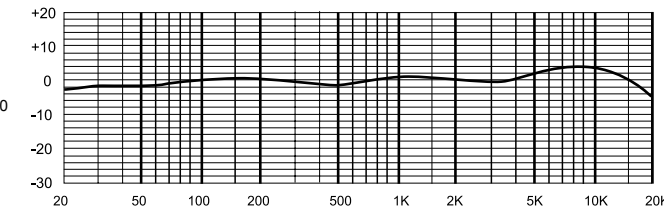
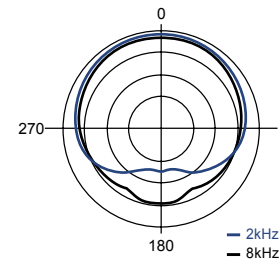

Type: Pressure gradient condenser capsule
 Diaphragm: 6 micron, gold-sputtered
 Frequency Range: 30Hz - 20kHz
 Polar Pattern: Cardioid
 Sensitivity: 10mV/Pa
 Impedance: 200 ohms
 S/N Ratio: 80 dB (Ref. 1Pa A-weighted)

Equivalent Noise Level: 18 dB (A-weighted IEC 268-4)
 Max SPL for 0.5% THD: 134 dB
 Power Requirements: 48V phantom power (+4V)
 Size: 86" x 5.2"/22mm x 133mm
 Weight: 0.3 lbs/136g (individual mic weight)
 Metal Finish: Silver

RF-100 | Portable Professional Reflection Filter



- Portable reflection filter for use in untreated rooms
- Outstanding control of acoustic reflections
- Adjustable side wings for easy fine-tuning
- Lightweight and compatible with most mic stands
- Packaged with all necessary mounting hardware

The MXL RF-100 reflection filter tames even the most challenging acoustic environments. It has a unique design which features adjustable side wings that make it easy to fine-tune a room. It's perfect for reducing awkward room reflections, giving extra isolation to a microphone or tweaking the sound of a recording. You'll get cleaner recordings with less work on the equalizer and the mixer.



Microphone, Stand, Shockmount & Cable not included



BCC-1 | Live Broadcast Condenser Microphone

The MXL BCC-1 brings a balanced sound to broadcasts. This small-diaphragm condenser microphone delivers detailed recordings with outstanding accuracy. It has a built-in shockmount and a tuned grill that eliminates internal reflections, so you'll get clean broadcasts with unwanted noise blocked out. And it's perfect for low voices, with a bass roll-off switch that captures all of the warmth but keeps the sound clear.



- Condenser broadcast mic that delivers a balanced sound
- Small-diaphragm capsule for detailed, accurate recordings
- Tuned grill that eliminates internal reflections
- Bass roll-off switch that gives extra clarity to lower voices
- Built-in shockmount that prevents unwanted noise



SPECS

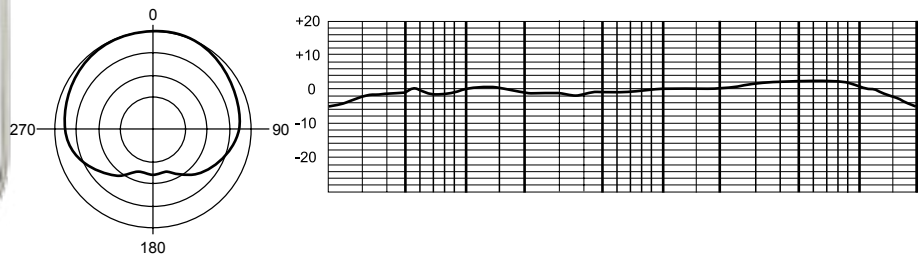

Type: Pressure gradient condenser
 Diaphragm: 6 micron, gold-sputtered
 Capsule Size: 0.87"/22mm
 Frequency Range: 20Hz - 20kHz
 Polar Pattern: Cardioid
 Sensitivity: -49 dB re 1 V/Pa
 Impedance: 150 ohms
 Equivalent Noise Level: -16 dB (A-weighted IEC 651)
 Max SPL for 0.5% THD: 148 dB SPL
 High Pass Filter: 6 dB/Octave @ 150Hz
 Power Requirements:
 Phantom power 48V (+/- 4V)
 Current Consumption: 5.2mA
 Size: 7.87" x 2.1"/200mm x 54mm
 (Not including mounting bracket)
 Weight: 1.6 lbs/720g
 Metal Finish: Nickel Plated



BCD-1 | Live Broadcast Dynamic Microphone

The MXL BCD-1 is a dynamic mic for dynamic broadcasters. It gives voices a bright sound that adds a little spark to broadcasts, and it's excellent for recording vocals for music. It's made to give clean recordings. The BCD-1 has outstanding side rejection, a built-in shockmount and a tuned grill that eliminates internal reflections, so unwanted noise won't stand a chance.



- Dynamic broadcast mic that delivers a bright sound
- Excellent side rejection that's great in a noisy room
- Tuned grill that eliminates internal reflections
- Built-in shock mount that prevents unwanted noise
- Also excellent for recording vocals for music



SPECS

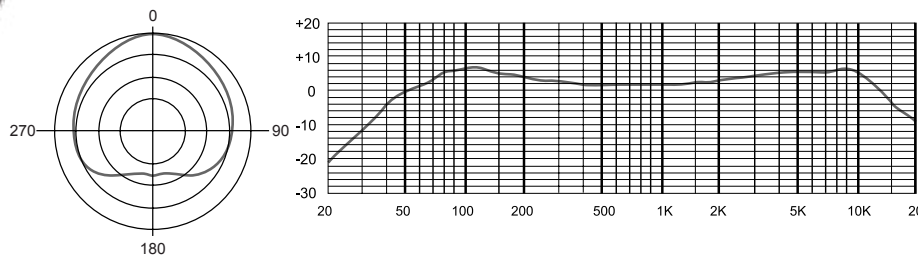

Type: Dynamic microphone
 Frequency Response: 40Hz - 15kHz
 Polar Pattern: Cardioid
 Sensitivity: -54 dB re 1 V/Pa
 Impedance: 600 ohms
 Size: 6.2" x 2.0"/157.5mm x 50.8mm
 Weight: 1.25 lbs/567g
 Metal Finish: Black

PROFESSIONAL MICROPHONE CABLES

for Studio, Live Stage and Broadcast

HIGH
PERFORMANCE

Marshall
Professional Microphone Cable
for Live Stage and Broadcast

- Designed for Ruggedness and High Performance
- 95% Coverage Copper Braid Shield
- High Cancellation of Noise -- both RFI and Hum
- Wide, Accurate Frequency Response
- OFC High Conductivity Copper

3', 6', 10', 25' lengths

The **Marshall Live Series** cables offer a rugged design with 95% copper braid shielding for maximum rejection of RFI, EMI and hum noise.

Ultra-Flexible Stage Ready Construction

- 95% Coverage Copper Braid Shield
- Heavy Duty 6mm Jacket
- Two-Conductor Cable

High Strength Fiber Filler



MXL BCD-Stand
Professional studio desktop microphone stand with built-in XLR cable. Includes screw mount and clamp mount
⊕ Mic not included

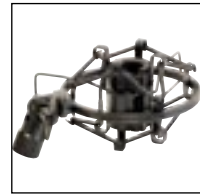

MXL 41-603
High-isolation shockmount (MXL 603, 604, 600, V67N and 991)



MXL-56
High-isolation shockmount for microphones with a tapered body (MXL 2001A, 2003, and 2010)

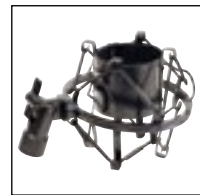

MXL-57 (Black)
High-isolation shockmount for MXL V67 Series, V69, 2006 and other mics with a 47mm diameter

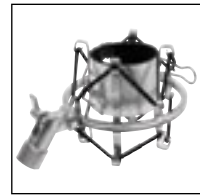

MXL-57-S (Silver)
High-isolation shockmount for MXL V67 Series, V69, 2006 and other mics with a 47mm diameter

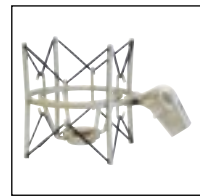

MXL-60
High-isolation shockmount designed for use with the GENESIS (Also available in black)



MXL-70
High-isolation shockmount for MXL 770/990 and other mics with a diameter of 60mm



MXL-90
Microphone shockmount for MXL 770/990 and other mics with a diameter of 60mm

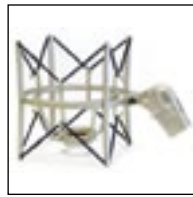

MXL USM-001
Universal heavy-duty basket shockmount (fits most MXL microphones)



MXL USM-002
Universal low profile shockmount (fits most MXL microphones)



MXL DS-01
Universal desktop tripod mic stand with extendable legs

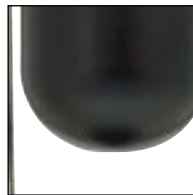

DS-O3
Desktop microphone table stand



PF-001
Universal condenser microphone pop filter



PF-002 (Black)
Universal metal mesh pop filter



PF-003 (Silver)
Universal metal mesh pop filter



MXL PS-69
Replacement power supply for V69 microphone

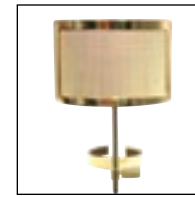

PF-005-G (Gold)
Metal mesh pop filter (Fits mics with diameter of 47.25mm or 1 7/8". Also fits MXL V67G, V67i, V67i Tube, 2001, 2003, 2006, V67Q, V63M, 3000, 909, and 990)



MXL 603/604 Omni Cap
Pair of omnidirectional capsules for MXL 603 and 604 mics



MXL WS-001
Windscreen for large grill microphones such as MXL V67G, V67i, 2006, V69, V6 and more



MXL WS-002
Windscreen for larger grill microphones (MXL 990, 960, 992, 770, 4000 and GENESIS)



MXL H-03
Hard mount mic stand adapter (MXL 603, 604, V67N and 991)



MXL MT-001
Hard mount mic stand adapter for most MXL microphones



MXL-V6-H
Hard mount mic stand adapter (MXL V6, M3, V87, USB.009 and Studio 1 USB)



MXL Mic Mate™ USB Mini Mixer
Portable Mixer Kit



PF-004-SS (Silver)
Metal mesh pop filter for MXL 4000 (Fits mics with diameter of 57.25mm or 2 1/4". Also fits MXL 960, 992, and 990 USB)

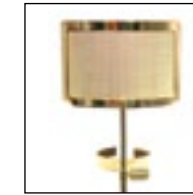

PF-004-G (Gold)
Metal mesh pop filter for GENESIS (Fits mics with diameter of 57.25mm or 2 1/4". Also fits MXL 960, 4000, 992, 990 USB)



MXL iBooster
Signal compatibility interface for Mac® computers



Marshall Professional Microphone Cable
For studio recording & audio broadcasting. Available in lengths of 3, 6, 10, 15, and 25 feet



MXL USB Cable 6
6 ft. USB 2.0 cable



MXL-V69 Cable1
15 ft. Mogami tube microphone cable for MXL V76t



MXL's Multi-use Microfiber Cleaning Cloth
A professional-grade polishing & cleaning material for microphones, instruments, computer screens, cell phones and more (Part #: MXL-CL/CL-01)



MXL RF-100
Portable professional reflection filter



Where Great Recordings Begin

Marshall Electronics

Professional Audio Division, El Segundo, CA

☎ Phone: 310.333.0606 / 800.800.6608 ⬇ Fax: 310.333.0688

🏠 www.mxlmics.com 📺 www.mogamicable.com ✉ sales@mxlmics.com

©2013 Marshall Electronics, Inc. All rights reserved

Designed and engineered in the USA

All logos for Marshall and all other references are trademarks and copyrights of their respective owners.