







# 1080 HD-SDI 5X Autofocus Lens Day/Night Camera

CV350-5X (Signal type: 1080P25/30, 1080i50/60, 720P50/60, 1080P50/60)  
 CV350-5XB (Signal type: 1080P29.97, 1080i59.94, 1080P59.94, 720P59.94)



## PRECAUTIONS

-  **WARNING** Do not use the camera if fumes, smoke or a strange odor is emitted from the unit, or if it seems to not function correctly. Disconnect the power source immediately and consult your supplier.
-  **CAUTION** Always follow the instructions in the installation guide when applying power. Fire and equipment damage can occur if power is applied incorrectly. For the correct power supply, refer to the
-  **CAUTION** Do not install or operate in small, unventilated areas. Heat build up
-  **CAUTION** To prevent damage, do not drop the camera or subject it to strong shock or vibration.
-  **CAUTION** If installed close to a TV, radio transmitter, magnet, electric motor interfere with or distort the image.
-  **CAUTION** Whether or not the camera is used outdoors, never point it toward the sun. Use caution when operating the camera in the vicinity of spot
-  **CAUTION** Do not use the camera in extreme environments where high temperatures or high humidity exists. Use the camera under conditions where temperatures are between 14°F ~ 122°F (-10°C ~ 50°C), and humidity is below 90%.

## REGULATORY NOTICE

This device complies with part 15 of the FCC Rules. Operation is subject to the following two conditions:  
 (1) This device may not cause harmful interference, and  
 (2) This device must accept any interference received, including interference that may cause undesired operation.

## FEATURES

Panasonic 2.3 Megapixel CMOS  
 5x Optical Zoom, F=4mm ~ 20mm, F2.8 ~ F3.9  
 HD-SDI(BNC), HDMI, and Analog CVBS (BNC)  
 0.2Lux (Color), 0.1Lux (B/W), 0.005Lux (DSS On)  
 Optical Multi Coated ICR Filter  
 3D-DNR, Privacy masking  
 Defog, HLC, WDR  
 Full OSD control  
 12VDC

## HARDWARE OVERVIEW: Front

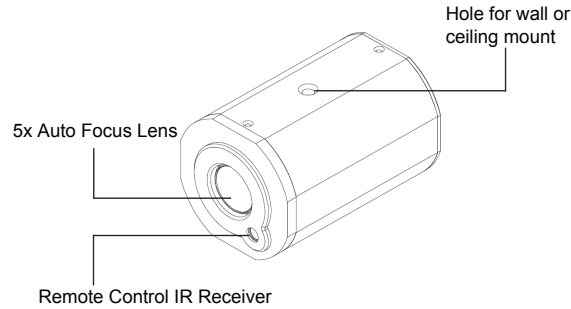

## HARDWARE OVERVIEW: Rear

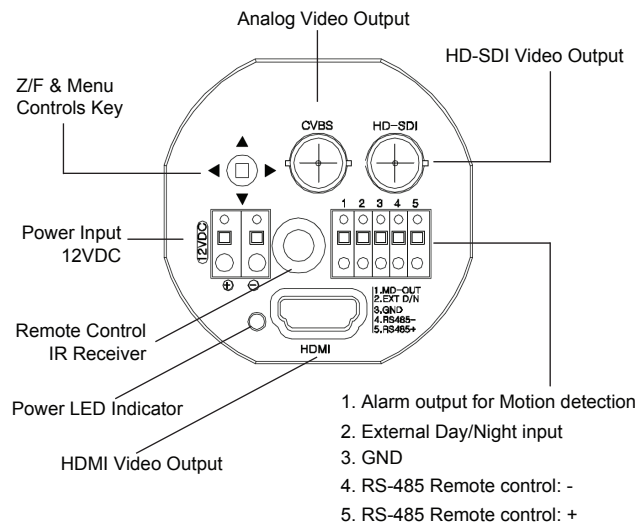

## Z/F & Menu Controls Key



- **MENU On, One Push AF Key**  
 Menu On: Press and hold menu key for 2seconds to display menu.  
 Menu Mode: To select data or exit from menu, press menu key.  
 One Push AF: To adjust focus position, press and release menu key when One Push AF mode is enabled.
- ▶ **Focus NEAR:** Press and hold right key for continuous optical focus near.  
 MENU: To change menu parameter, press right key while menu is displayed.
- ◀ **Focus Far:** Press and hold left key for continuous optical focus far.  
 MENU: To change menu parameter, press left key while menu is displayed.
- ▲ **Zoom TELE:** Press and hold up key for continuous optical zoom in(Tele).  
 MENU: To move up menu item, press up key while menu is displayed.
- ▼ **Zoom WIDE:** Press and hold down key for continuous optical zoom out(Wide).  
 MENU: To move down menu item, press down key while menu is displayed.

## SPECIFICATIONS

Sensor	Image Sensor	1/2.86" Progressive CMOS (Approx. 2.3 mega)	
	Scanning System	16:9 Progressive	
	Sync. System	Internal	
	Effective Pixel	1920(H) x 1080(V)	
Optics	Min. Illumination	0.2Lux (Day), 0.1Lux (Night), 0.005Lux(DSS on)	
	Horizontal Resolution	1000TVL	
	Lens	5x Optical Zoom, F=4.0-20mm, F2.8 ~ F3.9	
	Zoom	5x optical zoom + 12x digital zoom = 60x	
	Focus	Near/Far, Auto/Manual/One Push	
Functions	Angle of View(H)	64.2 degrees(WIDE), 13.8 degrees(TELE)	
	Back Light Compensation	WDR/BLC, HLC(High Light compensation)	
	Exposure	Auto / Manual	
	White Balance	Auto(3,000°K-8,000°K) / ATW(1,900°K-11,000°K) / Manual	
	Day & Night System	AGC / TDN(ICR)	
	Electronic Shutter	NTSC: 1/30-1/30000, PAL: 1/25-1/30000, DSS( ~ 1/1sec)	
	Functions	Privacy Mask, Image Mirror, 3DNR, Flicker-less, Sharpness, Defog	
	Video Output	SDI Output	SMPTTE 292M(1.485Gbps): 1080P@29.97, 720P@59.94 SMPTTE 424M(2.97Gbps): 1080P@59.94 800mVp-p, 75Ω, unbalanced generator(single-ended)
		CVBS (NTSC/ PAL)	Analog Composite(1V ± 0.2 Vp-p) NTSC/PAL
		HD Output	HDMI 1920x1080p@59.94, 1920x1080i@59.94, 1920x1080p@29.97, 1280x720p@59.94
Control Interface	RS485	PELCO-P/D, SONY-VISCA protocol 8bits data, 1 stop bit, no parity, 2400~115200bps	
	DIN input	OPEN(floating): Day mode, CLOSE: Night mode	
	Motion Detection out	High level signal(5VDC) output. MD output use transistor, connect lower than 100mA load.	
General	Operation Temperature	-10°C ~ 50°C	
	Power Input	12VDC (7V to 15VDC)	
	Power consumption	Max 6W (4.8W Lens inactive, 5.5W Lens active)	
	Weight	274g (0.6Lbs)	
Dimensions (D x W x H)	53.7 x 36.3 x 34.8mm (2.11 x 1.42 x 1.37")		

## DIMENSIONS

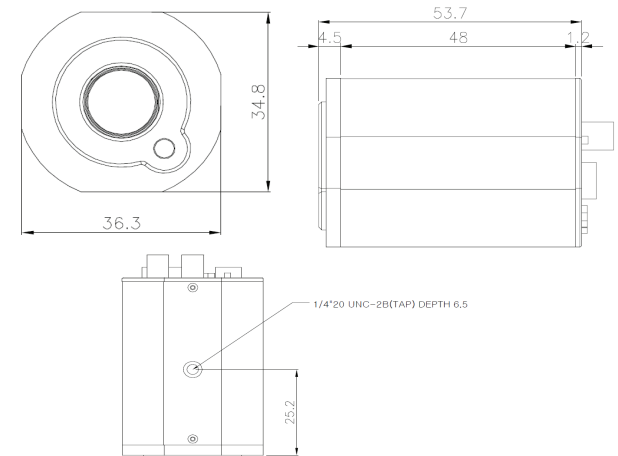

Design and specifications are subject to change without notice.

## Setup Menu of 1080 HD-SDI 5X Auto Focus Camera

SETUP	SUB MENU	SUB MENU	DESCRIPTION
WB CONTROL	AWB		Controls the automatic adjustment of the light source's color temperature to 3,000°K ~ 8,000°K.
	ATW		Continuously adjusts camera color balance in accordance with any change in color temperature. Compensates for color temperature changes within the range of
	PUSH		Color temperature will be manually adjusted by pushing the OSD button. Place the white paper in front of the camera when OSD button is pressed to obtain the
	INDOOR		Select this when the color temperature is between 4500K and 8500K.
	OUTDOOR		Select this when the color temperature is between 1700K and 11000K (Ex. Sodium light inclusion)
	MANUAL	BLUE, RED	Select this to fine-tune White Balance manually. You can adjust the blue and red tone level manually.
AE CONTROL (EXPOSURE)	INDOOR, OUTDOOR		Select one according to the location of camera installation. Then, select one sub-mode from AUTO, MANUAL, SHUTTER, PRIORITY, IRIS PRIORITY, and BRIGHT.
		AUTO	IRIS and SHUTTER are controlled automatically.
		MANUAL	IRIS, GAIN, and SHUTTER are controlled manually.
		SHUTTER PRIORITY	Manual SHUTTER and GAIN control with automatic IRIS control.
		IRIS PRIORITY	Manual IRIS and GAIN control with automatic SHUTTER control.
		BRIGHT	IRIS and GAIN can be controlled by control of BRIGHTNESS.
	BRIGHTNESS	MANUAL, 0~20	<b>0~20:</b> Adjust the screen brightness. <b>MANUAL:</b> BRIGHTNESS control is fixed, and give the exposure control priority to other resources.
	IRIS	AUTO, MANUAL, 0~20	<b>0~20:</b> Adjust the level of DSS. (OFF, 1/30, 1/15, 1/8, 1/4, 1/2) When it is in low luminance condition, DSS can adjust the picture quality by maintaining the light
	AGC LIMIT	0~20	A function which controls the amplification/gain process automatically if the illumination falls under the usable level.
	SHUTTER	AUTO, MANUAL, 1/2~40K	<b>1/2~40K:</b> Adjust the SHUTTER speed. (1/2, 4, 8, 15, 30, 60, 90, 120, 150, 180, 250, 350, 500, 725, 1000, 1500, 2K, 3K, 4K, 6K, 10K, 20K, 30K, 40K)
	DSS(SENS-UP)	MANUAL, OFF~1/2	<b>OFF~1/2:</b> Adjust the level of DSS. (OFF, 1/30, 1/15, 1/8, 1/4, 1/2) When it is in low luminance condition, DSS can adjust the picture quality by maintaining the light
FLICKERLESS	OFF, ON	Use this function when you experience picture flicker, this happens when there is a conflict with the installed lighting frequency.	
FOCUS CONTROL	FOCUS MODE	AUTO	Automatically adjusts the focus position.
		MANUAL	Manually adjusts the focus position when zoom is changed.
		PUSH	When this mode is enabled, it will automatically adjust the focus position only when the zoom is changed.
	ZOOM SPEED	0~7	Set the zoom speed.
	TELE LIMIT	X3~X60	Set the limit of the tele.
	WIDE LIMIT	X1~X2	Set the limit of the wide.
	FAR END	INFINITY, 2, 3, 5, 10M	Set the distance limit for the far focusing. The lens moves to adjust the focus from the distance.
	NEAR END	30CM, 1, 1.5, 2, 3, 5, 10M	Set the priority distance limit for near focusing.
	LENS INITIAL	OFF, AUTO, ONE PUSH	<b>AUTO:</b> The focus is automatically adjusted at the pre-set interval (01~07). <b>ONE PUSH:</b> The focus is re-adjusted when the OSD button is pushed over ONE PUSH.
	USER PRESET		This function is to set user defined zoom and focus position. Up to 32 preset position can be set with sub menu, USER PRESET, ACTIVE, SAVE, RESET.
BACK LIGHT	WDR/BLC	WDR	Enable user to view both object and background more clearly when background is too bright. Set the WDR-LEVEL (0~4).
		BLC	Enable a back light compensation feature.
		SPOT	Enables a user to select a desired area on a picture and view that area more clearly when background is too bright.
	ACE	GAIN	Brightness correction of the dark image area. Adjust the GAIN level (LOW, MIDDLE, HIGH).
	ECLIPSE	LEVEL	Highlight the bright area with a masking box with a selected color. Adjust the masking level (0~20).
IMAGE CONTROL		COLOR	Select the color for masking (GRN, MAG, RED, BLUE, BLK, WHT, YEL, CYN)
		D/N LEVEL	The camera will stay in DAY in a normal environment, but switched to NIGHT mode when ambient illumination become this pre-set level.
	AUTO	MARGIN	Set the margin between Day →Night switching level and Night →Day switching level. Different exposure gain level is needed to avoid malfunctions.
		DWELL TIME	Select the checking time of light condition to confirm to change from the day mode to the night mode.
		NIGHT BURST	Night burst OFF makes that the color burst is removed when ICR switches to black/white.
	DAY		The picture is always displayed in color.
	NIGHT	NIGHT BURST	The picture is always displayed in black/white.
		D/N LEVEL	The camera will stay in DAY in a normal environment, but switched to NIGHT mode when ambient illumination become this pre-set level.
	EXT	DWELL TIME	Select the interval time from the day mode to the night mode.
		NIGHT BURST	Alters the color burst information passed to the video monitor.
	COLOR LEVEL	0~20	Adjust the color level value for a fine color tune.
	SHARPNESS	0~20	As you increase this value, the picture outline becomes stronger and clearer.
	IMAGE FLIP		Video output will be flipped (MIRROR-HORIZONTALLY, FLIP-VERTICALLY, ROTATION).
	DEFOG	AUTO, MANUAL	This feature will help increase visibility in extreme weather conditions, such as fog, rain or in a very strong luminous intensity.
	3D-DNR	OFF, LOW, MIDDLE, HIGH	This feature will reduce the video noise at low ambient light.
MOTION		This feature will observe the object movement by motion zone and sensitivity that are pre-set with sub menu, DET. SIZE, SENSITIVITY, MASK ACTIVE, WIDTH,	
SHADING		This feature will correct the inconsistent brightness level in the image.	
GAMMA		This feature will adjust video output brightness (STANDARD, STRAIGHT, LOW, MIDDLE, HIGH).	
RESOLUTION		Change video output specification. <b>CV350-5X: 1080P25/30, 1080i50/60, 720P50/60, 1080P50/60. CV350-5XB: 1080P29.97, 1080i59.94, 1080P59.94, 720P59.94</b>	
DISPLAY CONTROL	USER TITLE		The camera title can be entered and it will appear over the video output.
	ZOOM MAGNIFICATION		Turn On or off of the zoom scale display.
	PRIVACY		Mask an area you want to hide on the screen with sub menu, MASK NO, MASK ACTIVE, MASK COLOR, WIDTH, HEIGHT, MOVE HOR, MOVE VER, TRANS, RESET
	ADDRESS	0~255	Select the camera ID number.
	ADDRESS DISPLAY	OFF, ON	Select the display of camera ID.
	BAUDRATE		Set the baudrate of RS-485 communication (2400, 4800, 9600, 19200, 38400, 57600, 115200).
	LANGUAGE		You can select the menu language according to your requirements. ( ENGLISH, 简体, FRANÇAIS, DEUTSCH, ESPAÑOL, PORTUGUÊS, РУССКИЙ)
	DEFECT ADJ		Defective pixels can be corrected.
	VER.		Display the firmware version.
RESET		Reset the camera settings to the factory defaults.	
EXIT		Exit the setup.	

Design and specifications are subject to change without notice.