

Display Station Series

Carts & Stands

a collection of carts and stands designed for a clean, aesthetically-pleasing installation and shipped with an integrated power strip

features:

- Designed for professionally-finished installations with a convenient cable management system and power strip incorporated into the support channel
- UL 1678 Listed for Institutional use, for multi-use environments including public, educational and institutional spaces
- Portrait to landscape adjustability of screen orientation after the display has been mounted (single post models only)
- Available with casters, levelers or floor plate
- Models available that mount single displays up to 100"



specifications:

DisplayStation Series Display carts and stands shall be Middle Atlantic Products model #DS-____-AL (see chart for available models). Overall dimensions of DS shall be ___"H x ___" W x ___"D (see drawing). DS shall have___ (Plate, Levelers, Casters (2 locking), refer to chart) base. DS shall accept 1 monitor, with a maximum VESA pattern of (____x____ to ____x____) and accept displays with a recommended diagonal measurement of (37" to 70", 60" to 100"), refer to chart. DS Series single post model shall have portrait to landscape screen adjustability (refer to drawing.) DS series shall have a clear anodized aluminum finish. DS shall have an overall weight capacity of (150, 185) lbs, with no more than (125, 175) lbs. for the monitor, refer to chart. DS shall include a 15 Amp power strip with 4 outlets and 12' cord with 5-15P termination. DS shall have integrated cable management. DS shall be UL Listed for institutional use to UL 1678 in the US and CAN/CSA C22.2 No. 60065-03 in Canada. DS shall comply with requirements of RoHS EU Directive 2002 / 95 / EC and 2011/65/EU. DS shall be manufactured by an ISO 9001 registered company. DS shall be warrantied to be free from defects in material or workmanship under normal use and conditions for 7 years.

Customizable specification clips available at middleatlantic.com



options:

- Camera Shelf shall be model # DS-CS108-BS, mounts above monitor, and have a usable mounting area of 11.1" x 8.15" and having a weight capacity of 5 lbs.
- Utility Shelf shall be model DS-UTS10-B, mount below monitor, have a usable mounting area of 10" wide by 11.25" deep and have a weight capacity of 10 lbs.
- Lock Box shall mount to the rear in a vertical or horizontal orientation, have a useable mounting area of 13.78" D x 15.75" W x 3.1" H, 10 lb. weight capacity and 4qty 1.18" cable pass through grommets in the rear

what **great systems** are built on.™

A brand of **legrand**



Middle Atlantic Products
middleatlantic.com | middleatlantic.ca

96-01216 / rev b / 10-6-16

Display Station Series

basic dimensions

all dimensions in inches unless otherwise noted [all dimensions in brackets are in millimeters]

DS-600SP-AL

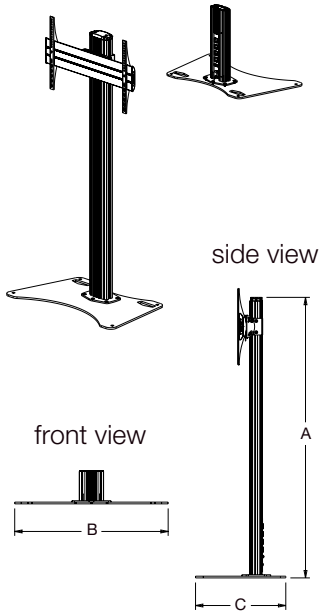

DS-600SL-AL

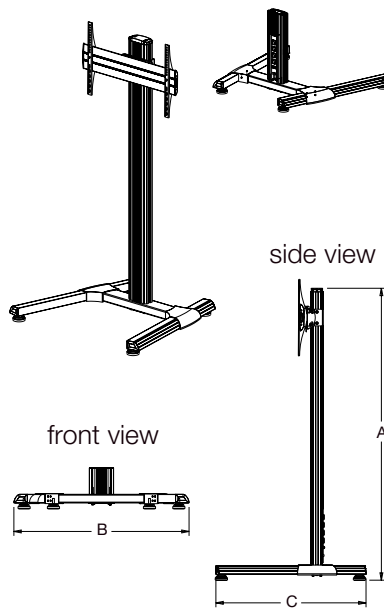

DS-600SC-AL

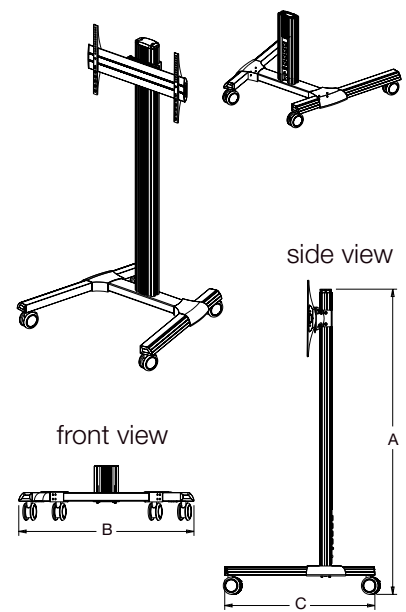

Part #	Description	A	B	C	Monitor Weight Capacity, Lb[Kg]	Total Weight Capacity w/ Accessories, Lb [Kg]	Min. VESA	Max. VESA	Recommended Display Size (Diagonal Measurement)	No. of Outlets Included On Power Strip
DS-600SP-AL	DS STAND,V600 SNGL,PLATE	63.63 [1616.3]	34.80 [884.0]	20.47 [520.0]	125 [56.7]	150 [68.2]	200x200	600X400	37"-70"	4
DS-600SL-AL	DS STAND,V600 SNGL,LEVELERS	64.34 [1634.3]	39.74 [1009.3]	34.12 [866.7]	125 [56.7]	150 [68.2]	200x200	600X400	37"-70"	4
DS-600SC-AL	DS STAND,V600 SNGL,CASTERS	67.81 [1722.4]	39.74 [1009.3]	34.05 [864.9]	125 [56.7]	150 [68.2]	200x200	600X400	37"-70"	4

what **great systems** are built on.™

A brand of **legrand**

Middle Atlantic Products

middleatlantic.com | middleatlantic.ca

Display Station Series

basic dimensions

all dimensions in inches unless otherwise noted [all dimensions in brackets are in millimeters]

DS-600SC-AL

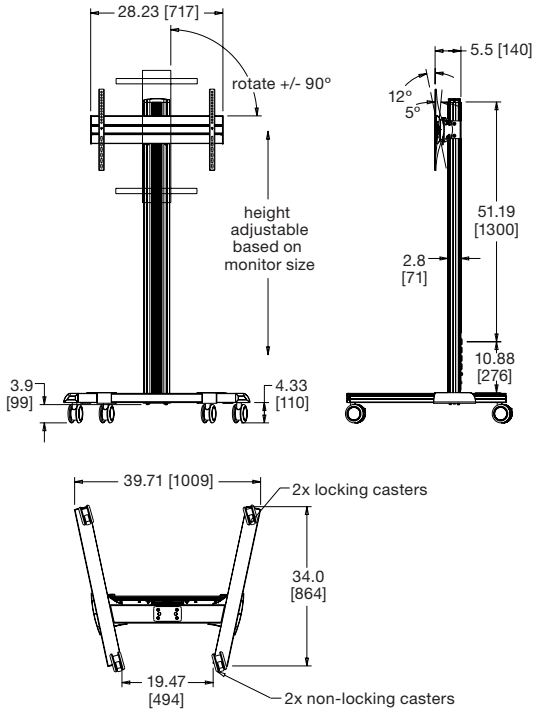

DS-600SP-AL

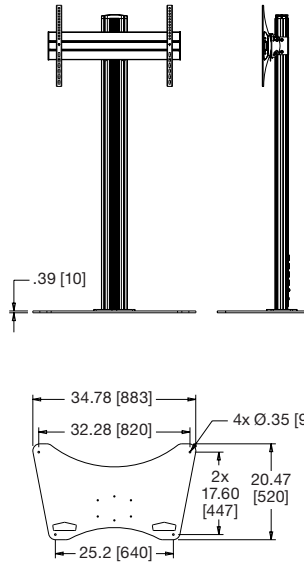

DS-600SL-AL

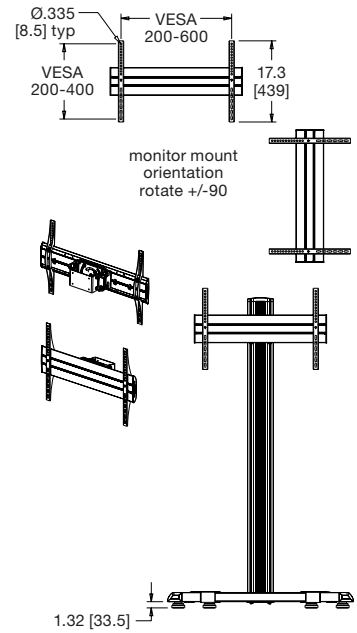

what **great systems** are built on.™

A brand of **legrand**

MA

Middle Atlantic Products

middleatlantic.com | middleatlantic.ca

Display Station Series

basic dimensions

all dimensions in inches unless otherwise noted [all dimensions in brackets are in millimeters]

DS-1000SL-AL

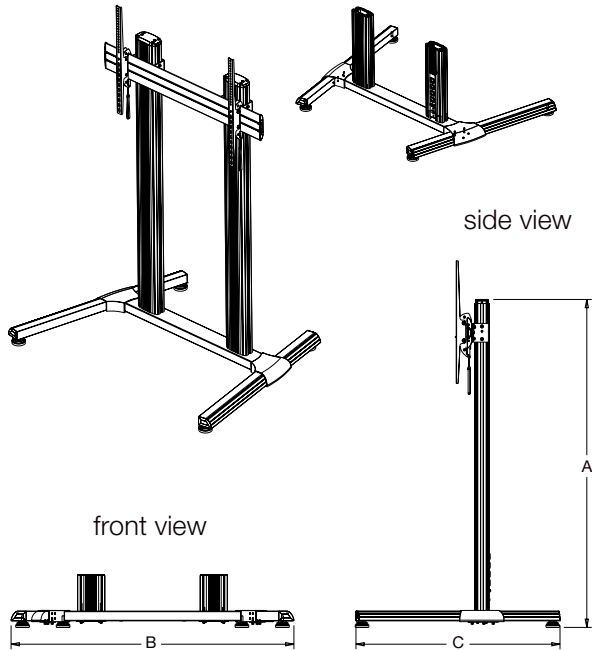

DS-1000SC-AL

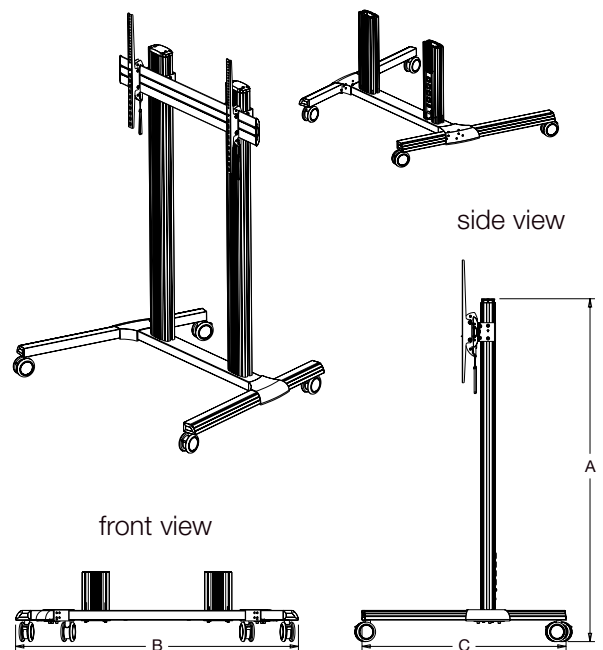

Part #	Description	A	B	C	Monitor Weight Capacity, Lb [Kg]	Total Weight Capacity w/ Accessories, Lb [Kg]	Min. VESA	Max. VESA	Recommended Display Size (Diagonal Measurement)	No. of Outlets Included On Power Strip
DS-1000SL-AL	DS STAND,V1000 SNGL,LEVELERS	64.34 [1634.3]	57.12 [1450.8]	41.30 [1049.0]	175 [79.4]	185 [83.9]	200x200	1000X600	60"-100"	4
DS-1000SC-AL	DS STAND,V1000 SNGL,CASTERS	67.81 [1722.4]	57.12 [1450.8]	41.23 [1047.2]	175 [79.4]	185 [83.9]	200x200	1000X600	60"-100"	4

what **great systems** are built on.™

A brand of **legrand**

Middle Atlantic Products

middleatlantic.com | middleatlantic.ca

Display Station Series

basic dimensions

all dimensions in inches unless otherwise noted [all dimensions in brackets are in millimeters]

DS-1000SC-AL

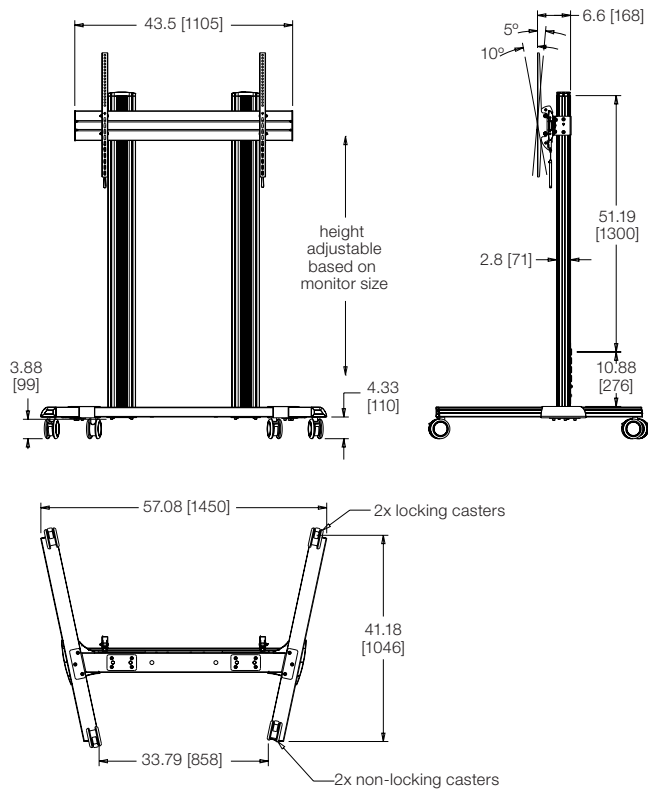

DS-1000SL-AL

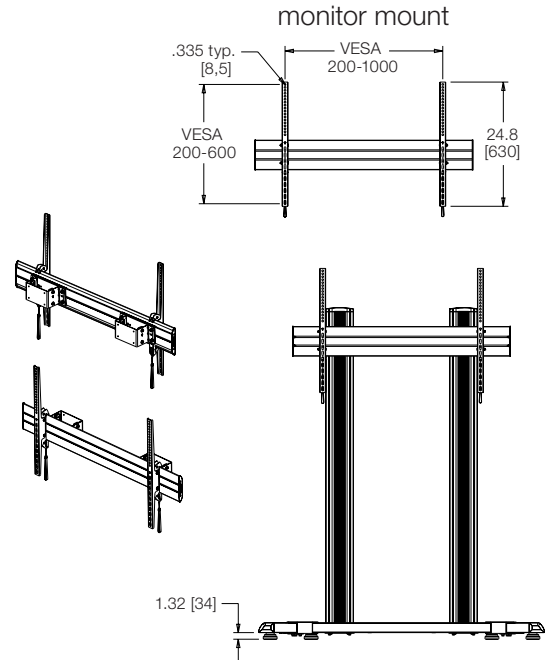

what **great systems** are built on.™

A brand of **legrand**

Middle Atlantic Products

middleatlantic.com | middleatlantic.ca

Display Station Series

basic dimensions

all dimensions in inches unless otherwise noted [all dimensions in brackets are in millimeters]

DS-LSH1416-B

front view

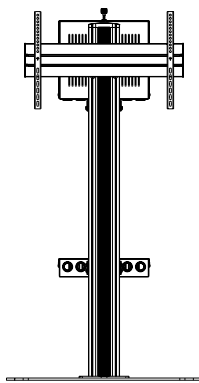

rear view

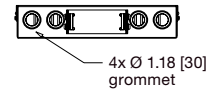
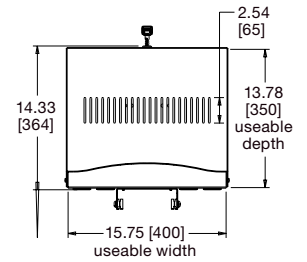
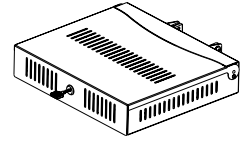
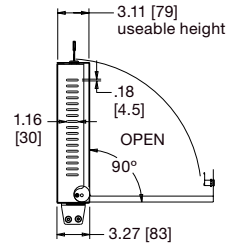
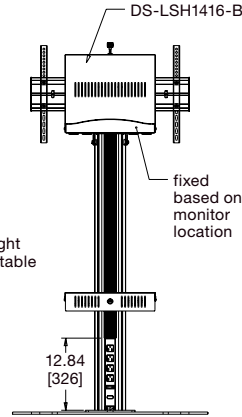

Part #	Description	Weight Capacity, Lb (KG)
DS-LSH1416-B	DS LOCKSHELF 14X16 BLACK	10 [4.5]

Display Station Series

basic dimensions

all dimensions in inches unless otherwise noted [all dimensions in brackets are in millimeters]

front view

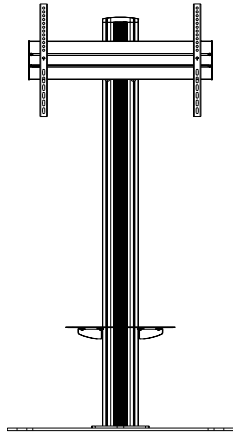

DS-UTS10-B

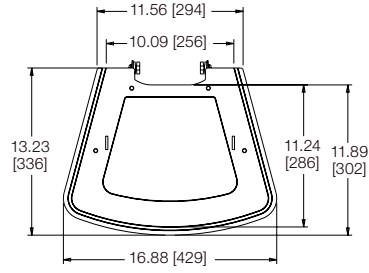
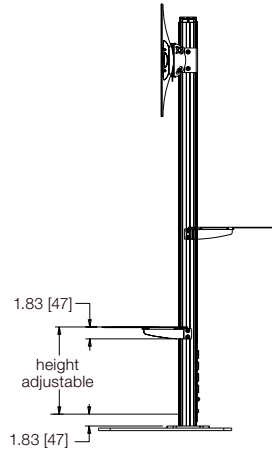

included strap

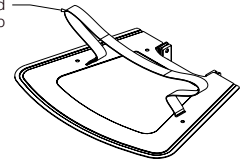

front view



Part #	Description	Weight Capacity, Lb (KG)
DS-UTS10-B	DS UTSHELF 10X10 BLACK	10 [4.5]

Display Station Series

basic dimensions

all dimensions in inches unless otherwise noted [all dimensions in brackets are in millimeters]

DS-CS108-B

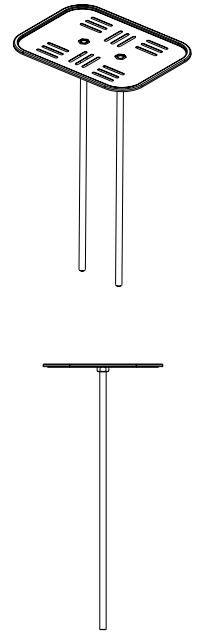
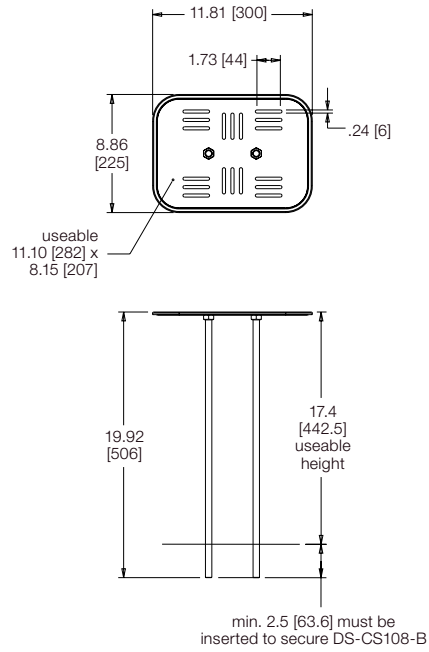
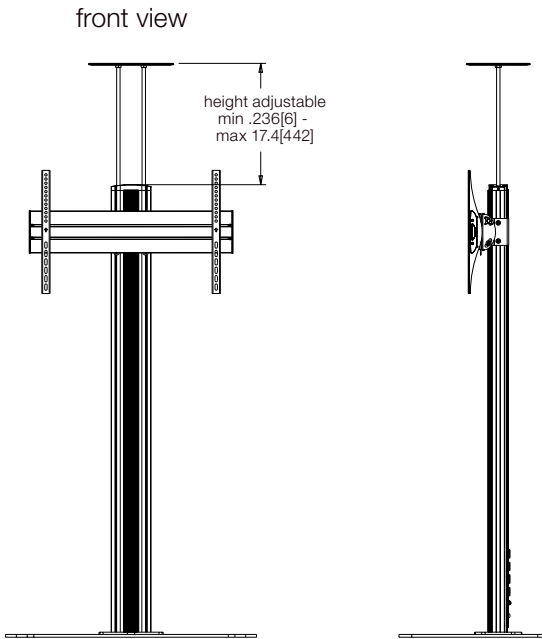

Part #	Description	Weight Capacity, Lb (KG)
DS-CS108-B	DS CAMERA SHELF 10X8	5 [2.2]

what **great systems** are built on.™

A brand of **legrand**

Middle Atlantic Products

middleatlantic.com | middleatlantic.ca

Display Station Series

basic dimensions

all dimensions in inches unless otherwise noted [all dimensions in brackets are in millimeters]

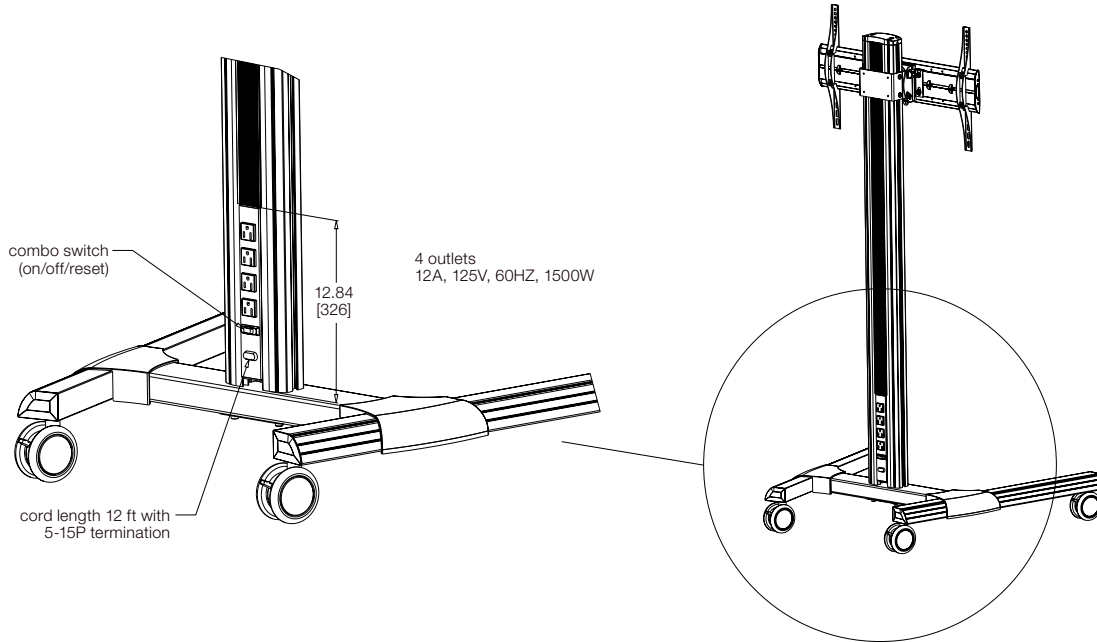

what **great systems** are built on.™

A brand of **legrand**

MA
Middle Atlantic Products
middleatlantic.com | middleatlantic.ca