



Middle Atlantic Products

EXCEPTIONAL SUPPORT & PROTECTION™

Fan Options



Control temperature within an enclosure with fan options and accessories

FAN-119

- 230V (50/60 Hz) nominal fan rated at 2.7 m³/min.
- 39 dBA (measurements made 1 meter from source, centered horizontally and vertically)
- Smooth, long life ball-bearing design
- CE compliant



FAN-119

QFAN-119

- 230V (50/60 Hz) nominal fan rated at 1.4 m³/min.
- <30 dBA (measurements made 1 meter from source, centered horizontally and vertically)
- Quiet fan includes fan guard with black powder coat finish
- Smooth, long life ball-bearing design
- CE compliant
- Used in:
 - QFP-1-119 (one fan) and QFP-2-119 (two fans) black anodized fan panels; QTFP-1-119 and QTFP-2-119 black textured powder coat fan panels



QFAN-119

FAN-254

- 230V (50/60 Hz) nominal fan rated at 15.6 m³/min.
- 49 dBA (measurements made 1 meter from source, centered horizontally and vertically)
- Smooth, long life ball-bearing design
- CE compliant



FAN-254

AXS-FAN-119

- 230V (50/60 Hz) nominal fan rated at 1.6 m³/min.
- 30 dBA (measurements made 1 meter from source, centered horizontally and vertically)
- Slim design fits AXS Series rack
- Smooth, long life ball-bearing design
- CE compliant
- Overtemp and fan failure notification via contact closure



AXS-FAN-119

IUQFP Series Ultra Quiet Fan Panel

- 2.8 m³/min. in 4 fan units, 1.4 m³/min. in 2 fan units
- Minimal friction, long-lasting hydrowave-bearing design
- Power supply with 1.8 meter cord
- Quiet operation, 27 dBA at full speed for 4 fan models, 24 dBA at full speed for 2 fan models
- Temperature display, LED indicators and designer-inspired aesthetic treatments available
- Fan speeds proportional to temperature of enclosure to extend fan life, reduce dust and maintenance
- CE compliant



IUQFP-4D

Specifications for Fan Options

MODEL#	SIZE	VOLTAGE (V nominal)	CURRENT (mA)	SPEED (RPM)	NOISE (dBA)	STATIC PRESSURE (Pa)	AIRFLOW (m ³ /min)
QFAN-119	119mm x 119mm x 38mm	230	45	1450	<30	17.4	1.4
FAN-119	119mm x 119mm x 38mm	230	100	2750	39	64.8	2.7
FAN-254	254mm x 89mm thk	230	250	1650	49	90.9	15.6
AXS-FAN-119	119mm x 119mm x 25.4mm	230	34	2300	30	22.4	1.6

**Mounting hole dimensions for
FAN-254**

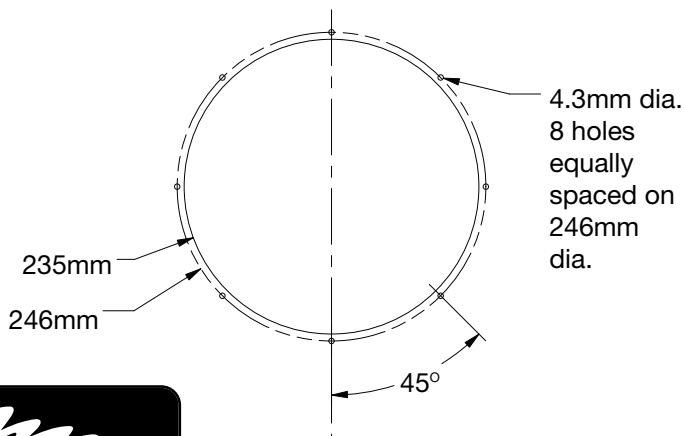

**Mounting hole dimensions for
QFAN-119, FAN-119, AXS-FAN-119**

