

Kaleido-X16

Super-silent, 16 input, dual output multiviewer

Hardware Description & Installation Manual

M869-9902-114

17 December 2014



Copyright & Trademark Notice

Copyright © 2009–2014, Grass Valley USA, LLC. All rights reserved.

Belden, Belden Sending All The Right Signals, and the Belden logo are trademarks or registered trademarks of Belden Inc. or its affiliated companies in the United States and other jurisdictions. Grass Valley, Miranda, Kaleido-X16, Kaleido-X, iControl, and Densité are trademarks or registered trademarks of Grass Valley USA, LLC. Belden Inc., Grass Valley USA, LLC, and other parties may also have trademark rights in other terms used herein.

Terms and Conditions

Please read the following terms and conditions carefully. By using Kaleido multiviewer documentation, you agree to the following terms and conditions.

Grass Valley hereby grants permission and license to owners of Kaleido multiviewers to use their product manuals for their own internal business use. Manuals for Grass Valley products may not be reproduced or transmitted in any form or by any means, electronic or mechanical, including photocopying and recording, for any purpose unless specifically authorized in writing by Grass Valley.

A Grass Valley manual may have been revised to reflect changes made to the product during its manufacturing life. Thus, different versions of a manual may exist for any given product. Care should be taken to ensure that one obtains the proper manual version for a specific product serial number.

Information in this document is subject to change without notice and does not represent a commitment on the part of Grass Valley.

Warranty information is available in the Support section of the Grass Valley Web site (www.grassvalley.com).

Title	Kaleido-X16 Hardware Description & Installation Manual
Part Number	M869-9902-114
Revision	17 December 2014, 5:06 pm

Important Safeguards and Notices

This section provides important safety guidelines for operators and service personnel. Specific warnings and cautions appear throughout the manual where they apply. Please read and follow this important information, especially those instructions related to the risk of electric shock or injury to persons.

Symbols and Their Meanings



Indicates that dangerous high voltage is present within the equipment enclosure that may be of sufficient magnitude to constitute a risk of electric shock.



Indicates that the user, operator or service technician should refer to the product manuals for important operating, maintenance, or service instructions.



This is a prompt to note the fuse rating when replacing fuses. The fuse referenced in the text must be replaced with one having the ratings indicated.



Identifies a protective grounding terminal which must be connected to earth ground prior to making any other equipment connections.

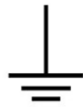

Identifies an external protective grounding terminal which may be connected to earth ground as a supplement to an internal grounding terminal.



Indicates that static sensitive components are present, which may be damaged by electrostatic discharge. Use anti-static procedures, equipment and surfaces during servicing.



Indicates that the equipment has more than one power supply cord, and that all power supply cords must be disconnected before servicing to avoid electric shock.



The presence of this symbol in or on Grass Valley equipment means that it has been tested and certified as complying with applicable Canadian Standard Association (CSA) regulations and recommendations for USA/Canada.



The presence of this symbol in or on Grass Valley equipment means that it has been tested and certified as complying with applicable Underwriters Laboratory (UL) regulations and recommendations for USA/Canada.



The presence of this symbol in or on Grass Valley equipment means that it has been tested and certified as complying with applicable Intertek Testing Services regulations and recommendations for USA/Canada.



The presence of this symbol in or on Grass Valley product means that it complies with all applicable European Union (CE) directives.



The presence of this symbol in or on Grass Valley product means that it complies with safety of laser product applicable standards.

Warnings



A warning indicates a possible hazard to personnel, which may cause injury or death. Observe the following general warnings when using or working on this equipment:

- Appropriately listed/certified mains supply power cords must be used for the connection of the equipment to the mains voltage at either 120 V AC or 240 V AC.
- This product relies on the building's installation for short-circuit (over-current) protection. Ensure that a fuse or circuit breaker for 120 V AC or 240 V AC is used on the phase conductors.
- Any instructions in this manual that require opening the equipment cover or enclosure are for use by qualified service personnel only.
- Do not operate the equipment in wet or damp conditions.
- This equipment is grounded through the grounding conductor of the power cords. To avoid electrical shock, plug the power cords into a properly wired receptacle before connecting the equipment inputs or outputs.
- Route power cords and other cables so they are not likely to be damaged. Properly support heavy cable bundles to avoid connector damage.
- Disconnect power before cleaning the equipment. Do not use liquid or aerosol cleaners; use only a damp cloth.
- Dangerous voltages may exist at several points in this equipment. To avoid injury, do not touch exposed connections and components while power is on.
- High leakage current may be present. Earth connection of product is essential before connecting power.
- Prior to servicing, remove jewelry such as rings, watches, and other metallic objects.
- To avoid fire hazard, use only the fuse type and rating specified in the service instructions for this product, or on the equipment.
- To avoid explosion, do not operate this equipment in an explosive atmosphere.
- Use proper lift points. Do not use door latches to lift or move equipment.
- Avoid mechanical hazards. Allow all rotating devices to come to a stop before servicing.
- Have qualified service personnel perform safety checks after any service.

Cautions



A caution indicates a possible hazard to equipment that could result in equipment damage. Observe the following cautions when operating or working on this equipment:

- This equipment is meant to be installed in a restricted access location.

- When installing this equipment, do not attach the power cord to building surfaces.
- Products that have no on/off switch, and use an external power supply must be installed in proximity to a main power outlet that is easily accessible.
- Use the correct voltage setting. If this product lacks auto-ranging power supplies, before applying power ensure that each power supply is set to match the power source.
- Provide proper ventilation. To prevent product overheating, provide equipment ventilation in accordance with the installation instructions.
- Do not operate with suspected equipment failure. If you suspect product damage or equipment failure, have the equipment inspected by qualified service personnel.
- To reduce the risk of electric shock, do not perform any servicing other than that contained in the operating instructions unless you are qualified to do so. Refer all servicing to qualified service personnel. Servicing should be done in a static-free environment.
- This unit may have more than one power supply cord. Disconnect all power supply cords before servicing to avoid electric shock.
- Follow static precautions at all times when handling this equipment.

Electrostatic Discharge (ESD) Protection



Electrostatic discharge occurs when electronic components are improperly handled and can result in intermittent failure or complete damage adversely affecting an electrical circuit. When you remove and replace any card from a frame always follow ESD-prevention procedures:

- Ensure that the frame is electrically connected to earth ground through the power cord or any other means if available.
- Wear an ESD wrist strap ensuring that it makes good skin contact. Connect the grounding clip to an *unpainted surface* of the chassis frame to safely ground unwanted ESD voltages. If no wrist strap is available, ground yourself by touching the *unpainted* metal part of the chassis.
- For safety, periodically check the resistance value of the antistatic strap, which should be between 1 and 10 megohms.
- When temporarily storing a card make sure it is placed in an ESD bag.
- Cards in an earth grounded metal frame or casing do not require any special ESD protection.

Battery Handling



This product includes a backup battery. There is a danger of explosion if the battery is replaced incorrectly. Replace the battery only with the same or equivalent type recommended by the manufacturer. Dispose of used batteries according to the manufacturer's instructions. Before disposing of your Grass Valley equipment, please review the *Disposal and Recycling Information* appendix.

Mesures de sécurité et avis importants

La présente section fournit des consignes de sécurité importantes pour les opérateurs et le personnel de service. Des avertissements ou mises en garde spécifiques figurent dans le manuel, dans les sections où ils s'appliquent. Prenez le temps de bien lire les consignes et assurez-vous de les respecter, en particulier celles qui sont destinées à prévenir les décharges électriques ou les blessures.

Signification des symboles utilisés



Signale la présence d'une tension élevée et dangereuse dans le boîtier de l'équipement ; cette tension peut être suffisante pour constituer un risque de décharge électrique.



Avertit l'utilisateur, l'opérateur ou le technicien de maintenance que des instructions importantes relatives à l'utilisation et à l'entretien se trouvent dans la documentation accompagnant l'équipement.



Invite l'utilisateur, l'opérateur ou le technicien de maintenance à prendre note du calibre du fusible lors du remplacement de ce dernier. Le fusible auquel il est fait référence dans le texte doit être remplacé par un fusible du même calibre.



Identifie une borne de mise à la terre de protection. Il faut relier cette borne à la terre avant d'effectuer toute autre connexion à l'équipement.

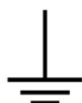

Identifie une borne de mise à la terre externe qui peut être connectée en tant que borne de mise à la terre supplémentaire.



Signale la présence de composants sensibles à l'électricité statique et qui sont susceptibles d'être endommagés par une décharge électrostatique. Utilisez des procédures, des équipements et des surfaces antistatiques durant les interventions d'entretien.



Le symbole ci-contre signifie que l'appareil comporte plus d'un cordon d'alimentation et qu'il faut débrancher tous les cordons d'alimentation avant toute opération d'entretien, afin de prévenir les chocs électriques.



La marque C-CSA-US certifie que l'appareil visé a été testé par l'Association canadienne de normalisation (CSA) et reconnu conforme aux exigences applicables en matière de sécurité électrique en vigueur au Canada et aux États-Unis.



La marque C-UL-US certifie que l'appareil visé a été testé par Underwriters Laboratory (UL) et reconnu conforme aux exigences applicables en matière de sécurité électrique en vigueur au Canada et aux États-Unis.



La marque ETL Listed d'Intertek pour le marché Nord-Américain certifie que l'appareil visé a été testé par Intertek et reconnu conforme aux exigences applicables en matière de sécurité électrique en vigueur au Canada et aux États-Unis.



Le marquage CE indique que l'appareil visé est conforme aux exigences essentielles des directives applicables de l'Union européenne en matière de sécurité électrique, de compatibilité électromagnétique et de conformité environnementale.



Le symbole ci-contre sur un appareil Grass Valley ou à l'intérieur de l'appareil indique qu'il est conforme aux normes applicables en matière de sécurité laser.

Avertissements



Les avertissements signalent des conditions ou des pratiques susceptibles d'occasionner des blessures graves, voire fatales. Veuillez vous familiariser avec les avertissements d'ordre général ci-dessous :

- Un cordon d'alimentation dûment homologué doit être utilisé pour connecter l'appareil à une tension de secteur de 120 V CA ou 240 V CA.
- La protection de ce produit contre les courts-circuits (surintensités) dépend de l'installation électrique du bâtiment. Assurez-vous qu'un fusible ou un disjoncteur pour 120 V CA ou 240 V CA est utilisé sur les conducteurs de phase.
- Dans le présent manuel, toutes les instructions qui nécessitent d'ouvrir le couvercle de l'équipement sont destinées exclusivement au personnel technique qualifié.
- N'utilisez pas cet appareil dans un environnement humide.
- Cet équipement est mis à la terre par le conducteur de mise à la terre des cordons d'alimentation. Pour éviter les chocs électriques, branchez les cordons d'alimentation sur une prise correctement câblée avant de brancher les entrées et sorties de l'équipement.
- Acheminez les cordons d'alimentation et autres câbles de façon à ce qu'ils ne risquent pas d'être endommagés. Supportez correctement les enroulements de câbles afin de ne pas endommager les connecteurs.
- Coupez l'alimentation avant de nettoyer l'équipement. Ne pas utiliser de nettoyeurs liquides ou en aérosol. Utilisez uniquement un chiffon humide.
- Des tensions dangereuses peuvent exister en plusieurs points dans cet équipement. Pour éviter toute blessure, ne touchez pas aux connexions ou aux composants exposés lorsque l'appareil est sous tension.
- Avant de procéder à toute opération d'entretien ou de dépannage, enlevez tous vos bijoux (notamment vos bagues, votre montre et autres objets métalliques).
- Pour éviter tout risque d'incendie, utilisez uniquement les fusibles du type et du calibre indiqués sur l'équipement ou dans la documentation qui l'accompagne.
- Ne pas utiliser cet appareil dans une atmosphère explosive.
- Présence possible de courants de fuite. Un raccordement à la masse est indispensable avant la mise sous tension.

- Après tout travail d'entretien ou de réparation, faites effectuer des contrôles de sécurité par le personnel technique qualifié.

Mises en garde



Les mises en garde signalent des conditions ou des pratiques susceptibles d'endommager l'équipement. Veuillez vous familiariser avec les mises en garde ci-dessous :

- L'appareil est conçu pour être installé dans un endroit à accès restreint.
- Au moment d'installer l'équipement, ne fixez pas les cordons d'alimentation aux surfaces intérieures de l'édifice.
- Les produits qui n'ont pas d'interrupteur marche-arrêt et qui disposent d'une source d'alimentation externe doivent être installés à proximité d'une prise de courant facile d'accès.
- Si l'équipement n'est pas pourvu d'un module d'alimentation auto-adaptable, vérifiez la configuration de chacun des modules d'alimentation avant de les mettre sous tension.
- Assurez une ventilation adéquate. Pour éviter toute surchauffe du produit, assurez une ventilation de l'équipement conformément aux instructions d'installation.
- N'utilisez pas l'équipement si vous suspectez un dysfonctionnement du produit. Faites-le inspecter par un technicien qualifié.
- Pour réduire le risque de choc électrique, n'effectuez pas de réparations autres que celles qui sont décrites dans le présent manuel, sauf si vous êtes qualifié pour le faire. Confiez les réparations à un technicien qualifié. La maintenance doit se réaliser dans un milieu libre d'électricité statique.
- L'appareil peut comporter plus d'un cordon d'alimentation. Afin de prévenir les chocs électriques, débranchez tous les cordons d'alimentation avant toute opération d'entretien.
- Veillez à toujours prendre les mesures de protection antistatique appropriées quand vous manipulez l'équipement.

Protection contre les décharges électrostatiques (DES)



Une décharge électrostatique peut se produire lorsque des composants électroniques ne sont pas manipulés de manière adéquate, ce qui peut entraîner des défaillances intermittentes ou endommager irrémédiablement un circuit électrique. Au moment de remplacer une carte dans un châssis, prenez toujours les mesures de protection antistatique appropriées :

- Assurez-vous que le châssis est relié électriquement à la terre par le cordon d'alimentation ou tout autre moyen disponible.
- Portez un bracelet antistatique et assurez-vous qu'il est bien en contact avec la peau. Connectez la pince de masse à une *surface non peinte* du châssis pour détourner à la terre toute tension électrostatique indésirable. En l'absence de bracelet antistatique, déchargez l'électricité statique de votre corps en touchant une surface métallique *non peinte* du châssis.

- Pour plus de sécurité, vérifiez périodiquement la valeur de résistance du bracelet antistatique. Elle doit se situer entre 1 et 10 mégohms.
- Si vous devez mettre une carte de côté, assurez-vous de la ranger dans un sac protecteur antistatique.
- Les cartes qui sont reliées à un châssis ou boîtier métallique mis à la terre ne nécessitent pas de protection antistatique spéciale.

Remplacement et élimination des piles



L'appareil renferme une pile. Pour réduire le risque d'explosion, vérifiez la polarité et ne remplacez la pile que par une pile du même type, recommandée par le fabricant. Mettez les piles usagées au rebut conformément aux directives du fabricant. Avant de vous défaire de l'équipement, assurez-vous d'avoir lu l'appendice *Disposal and Recycling Information*.

Recycling

Visit www.grassvalley.com for recycling information.

Certification and Compliance

Safety Compliance



This equipment complies with the requirements of the following standards for safety of information technology equipment:

- CSA-C22.2 No. 60950-1-07 (2nd Edition)
- UL 60950-1 (2nd Edition)
- EN 60950-1:2006 ITE
- IEC 60950-1:2005 (2nd Edition)

The power cords supplied with this equipment meet the appropriate national standards for the country of destination.

Electromagnetic Compatibility



This equipment has been tested for verification of compliance with FCC Part 15, Subpart B requirements for class A digital devices.

Note: This equipment has been tested and found to comply with the limits for a Class A digital device, pursuant to Part 15 of the FCC rules. These limits are designed to provide reasonable protection against harmful interference when the equipment is operated in a commercial environment. This equipment generates, uses, and can radiate radio frequency energy, and, if not installed and used in accordance with the instruction manual, may cause harmful interference to radio communications. Operation of this equipment in a residential area is likely to cause harmful interference in which case the user will be required to correct the interference at his own expense.

CE This equipment has been tested and found to comply with the requirements of the EMC directive 2004/108/EC:

- EN 55022 Class A Radiated and conducted emissions
- EN 61000-3-2 Limits for harmonic current emissions
- EN 61000-3-3 Limitation of voltage fluctuations and flicker
- EN 61000-4-2 Electrostatic discharge immunity
- EN 61000-4-3 Radiated, radio-frequency, electromagnetic field immunity
- EN 61000-4-4 Electrical fast transient immunity
- EN 61000-4-5 Surge transient immunity
- EN 61000-4-6 Conducted disturbances immunity
- EN 61000-4-8 Power frequency magnetic field immunity
- EN 61000-4-11 Voltage dips, short interruptions and voltage variations immunity

toc

Table of Contents

1 Kaleido-X16 Installation	1
Introduction.....	1
Mechanical Installation	4
Frame and Electrical Installation	5
CompactFlash.....	11
Signalling	11
Maintenance	21
2 Specifications	23
Inputs.....	23
Outputs.....	25
Audio I/O.....	28
Control.....	28
Frame.....	29
Appendix: Disposal and Recycling Information.....	31
Contact Us	33

1

Kaleido-X16 Installation

The Kaleido-X16 is a 1RU, multi-image display processor with high image quality and a rich feature set. This chapter contains physical descriptions, installation instructions and connection information for the Kaleido-X16 frame.

Summary

<i>Introduction</i>	1
<i>Mechanical Installation</i>	4
<i>Frame and Electrical Installation</i>	5
<i>CompactFlash</i>	11
<i>Signalling</i>	11
<i>Maintenance</i>	21

Introduction

The Kaleido-X16 system is a cost-effective multi-image processor. It can accommodate smaller systems or scale up to production systems, where smaller building blocks with fewer input counts per display are desirable. Each chassis can display up to 16 auto-sensing HD, SD, or Analog inputs that can be displayed across two high resolution outputs at multiple sizes.



Features

Small form factor	1RU
Expandable	Expandable multi-room architecture, based on a chassis with 16 inputs, and 2 independent multi-image display outputs
Unmatched flexibility	Any source can be repeated to any position, to any display, at any size, at any resolution, without blocking or grouping restrictions

Kaleido-X16 as a router	The Kaleido-X16 can behave as a router, with 16 input channels as sources and the two <i>RT OUT</i> outputs as destinations
Superior display	Highest quality multi-image output without compression, with superior on-screen graphics, for the most critical live monitoring applications
128 audio channels	Unprecedented audio performance with the ability to monitor up to 128 channels of audio, including embedded, discrete analog, discrete AES from ABT
DVI inputs	DVI inputs (one per output head) mappable in the background of each output without the need for scaling
Two-room layouts	Intuitive layout editor software allows rapid creation of two-room layouts, which can be recalled quickly from networked remote control panels
Highly robust	Highly robust design, with multiple points of redundancy, and no single point of failure for reliable 24/7 operation

Port Availability

The Kaleido-X16 offers a wide variety of ports for incoming and outgoing signals. However, with a view towards future expansion, there are ports whose connections exist but that are currently not fully supported. The following ports on the Kaleido-X16 are not yet supported:

- OPTION streaming output connector
- PC In analog audio input ports at the Audio I/O connector

Overview of the Kaleido-X16 System

The following diagram shows a basic Kaleido-X16 system configuration, with a single Kaleido-X16 feeding 2 monitor wall displays. The Kaleido-RCP2 would be located on the production desk, while the Client PC could be anywhere with Internet access to the network.

The diagram below shows a Kaleido-X16 system with its inputs and outputs. Examples of the various external devices that connect to the Kaleido-X16 are also shown.

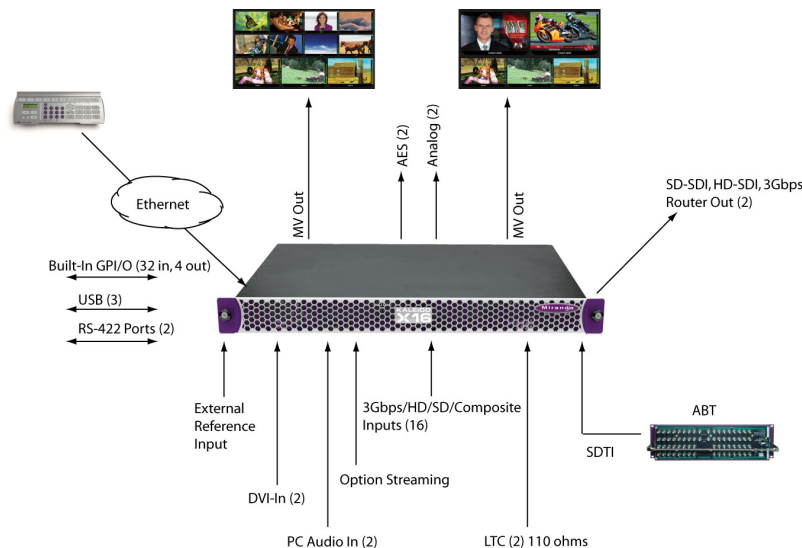

The Kaleido-X16 system is available in two model types: a single-head model (Kaleido-X16-S) and a dual-head model (Kaleido-X16-D). Throughout this manual, *Kaleido-X16* refers to both models unless it is necessary to distinguish the single-head model from the dual-head model.

Kaleido-X16-D

There are two heads (Head 1 and Head 2) on the dual-head Kaleido-X16 (Kaleido-X16-D). The Input and Output connections are as follows.

Connector	Number of connectors on Head 1	Number of connectors on Head 2
MV OUT	1	1
SDI OUT	1	1
DVI IN	1	1

The rear connector panel for this model is displayed, below:

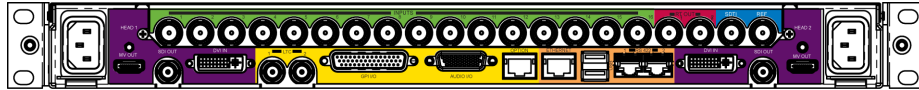

In addition to the difference in the number of output heads, the Audio I/O TBA pinout is different between the two models (see [Audio I/O TBA](#), on page 14 for details).

Kaleido-X16-S

There is one head (Head 1) on the single-head Kaleido-X16 (Kaleido-X16-S). The Input and Output connections are as follows.

Connector	Number of connectors on Head 1
MV OUT	1
SDI OUT	1
DVI IN	1

The rear connector panel for this model is displayed, below:

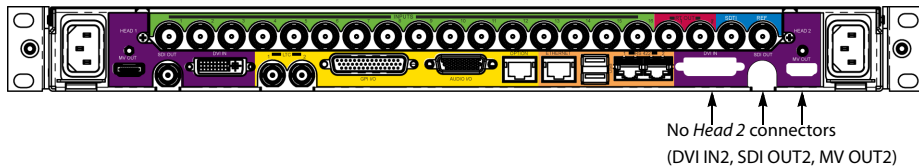

In addition to the difference in the number of heads, the Audio I/O TBA pinout is different between the two models (see [Audio I/O TBA](#), on page 14 for details).

Mechanical Installation

Unpacking

Make sure the following items have been shipped with your Kaleido-X16. If any of these are missing, contact your distributor or Grass Valley.

- Kaleido-X16 unit with one or two power supplies pre-installed (second power supply optional)
- Two support brackets
- One AC power cord per power supply
- DVD including manuals, software and release notes
- One mouse
- Four serial port adapters (one with straight wiring and one with crossover wiring for each of the two RS-422 ports on your multiviewer):

Part number	Adapter cabling	RS-422 pinout at the DE-9P connector
1737-3000-102	Straight	Controller (SMPTE master) mode
1792-3700-100	Crossover	Tributary (SMPTE slave) mode

Notes

- The Kaleido-RCP2 unit is optional and is not included in the standard Kaleido-X16 package. Refer to the Kaleido-RCP2 Guide to Installation and Operation (available on the DVD that shipped with your system) for more information.
 - The standard Kaleido-X16 comes with one PSU. A redundant, second PSU is optional.
-

Mounting the Kaleido-X16 in a Rack

To mount the Kaleido-X16 in a standard 19-inch rack

- 1 Install both support brackets at the back of the rack by using suitable screws and washers (not included), so that the bottom of the Kaleido-X16 frame will be supported by the brackets.

- 2 Insert the Kaleido-X16 frame at the designated location within the rack, and secure the front of the frame to the rack by using suitable screws and washers (not included).

IMPORTANT

Mobile Installation

If you are deploying your Kaleido-X16 in a mobile unit, it is your responsibility to make sure the back of the multiviewer is securely attached to the rack. For instance you may install a blank panel at the back of the rack, so that it meets the top of the frame, to prevent the frame from bouncing away from the support brackets.

Ventilation

For proper ventilation, make sure the front and side panel air vents are not blocked and the air filter is clean.

Note: The optional Kaleido-RCP2 may also be installed in a rack, by using the KRCP-RK2 mounting kit.

Frame and Electrical Installation

The Kaleido-X16 multiviewer is a self-contained unit consisting of a frame, redundant power supplies, and various input and output cards. The monitor wall displays and external control devices complete the system.

Frame

The Kaleido-X16 frame is 1 RU high. Input and output connectors are mounted on a connector panel on the rear of the frame. The redundant power supply is installed in the front of the frame. The front cover can be removed to give access to the PSUs, CompactFlash card, USB connector, and basic LEDs.

The Kaleido-X16 frame incorporates the following key elements:

- A rack-mountable mechanical framework (for mounting into a 19-inch EIA rack)
- A removable door to cover and protect the front of the frame
- An optional redundant power supply
- Ventilation



Front view of the Kaleido-X16 frame (PSUs installed; front cover removed)

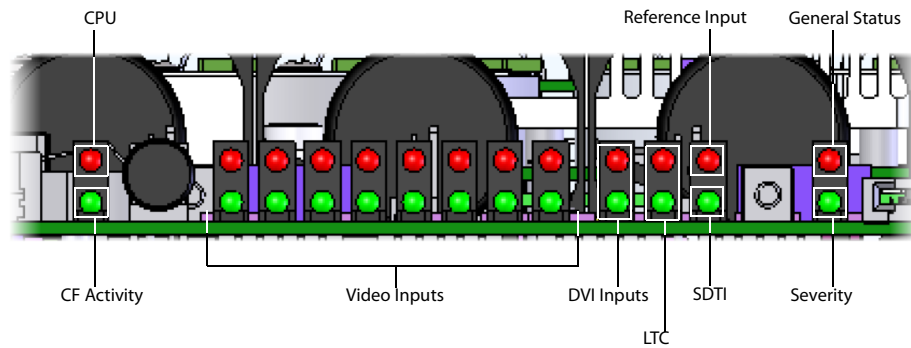

LEDs on the front of the frame (behind the cover)

The LEDs on the front of the frame (behind the cover) indicate the following conditions depending on their color and whether they are blinking or not:

LED	LED Status						
	Green	Blinking green	Red	Blinking red	Yellow	Blinking yellow	Off
CPU	Normal operation	Application booting	Error	Live Update	OS Booting	N/A	Front cover is closed
CPF Activity	N/A	Activity	N/A	N/A	N/A	N/A	No Activity
Video Inputs	Inputs are locked	N/A	Inputs are unlocked, or no input	ERROR ON SIGNAL	N/A	N/A	Front cover is closed
DVI Inputs	Inputs are locked	N/A	Inputs are unlocked, or no input	ERROR ON SIGNAL	N/A	N/A	Front cover is closed
LTC	LTC valid	N/A	No signal	N/A	N/A	N/A	Front cover is closed
Ref. Input	Input is locked	N/A	Input is unlocked, or no input	ERROR ON SIGNAL	N/A	N/A	Front cover is closed
SDTI	Inputs are locked	N/A	Inputs are unlocked, or no input, or no SDTI signal	ERROR ON SIGNAL	N/A	N/A	Front cover is closed
Gen. Status	System OK	Intrusive self-diagnostic finished	Configuration Failed, Safe Mode	Firmware Upgrading	Boot up Diagnostic (Verbose switch on)	Firmware error	Front cover is closed
Severity	Boot OK	Booting	Boot error, Need live-update	Fatal error, CALL TECH SUPPORT	N/A	N/A	No power

Monitoring the Temperature of the Kaleido-X16

For optimal performance, it is strongly recommended that you operate the Kaleido-X16 multiviewer in an environment with an ambient temperature between 0 °C and 40 °C.

IMPORTANT

When measuring the ambient room temperature, take your readings from directly in front of the Kaleido-X16 frame.

There are two factors that could influence airflow inside the frame: altitude and airflow obstruction on the sides of the unit.

Power Supplies

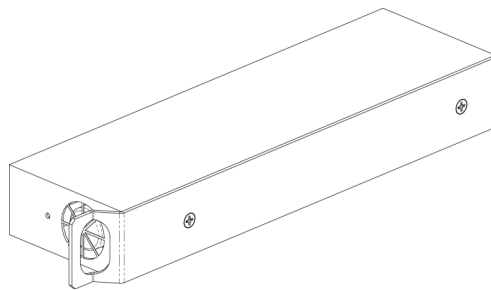

Power supply for the Kaleido-X16 frame

The Kaleido-X16 frame is powered by dual redundant, current-sharing power supply units (PSUs). The PSUs are installed and removed from the front of the frame and are hot-swappable, so that a defective supply may be replaced without removing the Kaleido-X16 frame from service. When facing the front of the frame, the PSU on the left side is referred to as *PSU A* and the PSU on the right side is *PSU B*.

IMPORTANT

If your frame has only one PSU, it must be installed in Slot A (left side of frame)

There are two power supplies: an operational PSU and a redundant PSU. The system operates with a single PSU. If you choose to have only one PSU installed in your Kaleido-X16 frame, you should do the following:

- Clear the **PSU B Installed** check box for this Kaleido-X16 frame in XAdmin (see the “Configuring Power Supply Redundancy on the Kaleido-X16” section in the *Getting Started* chapter of the Kaleido-X User’s Manual).
- Install the single PSU (PSU A) in Slot A (the left side of the frame when facing the front of the frame) (see [Installing a Power Supply](#), on page 8).

Access the power supplies by removing the front cover of the frame. Viewed from the front of the frame, the PSUs are located on the left-hand and right-hand sides of the frame:

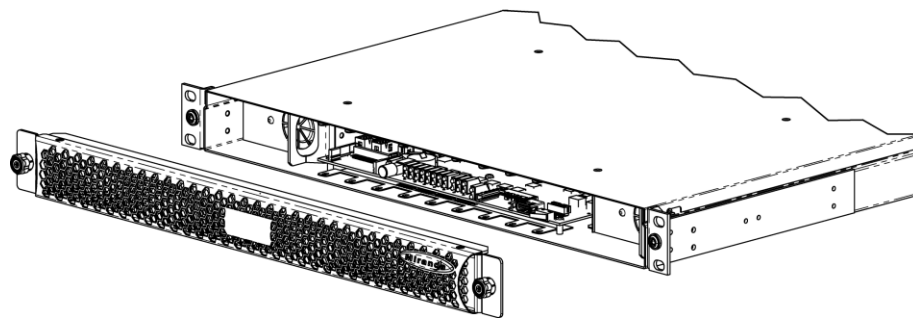
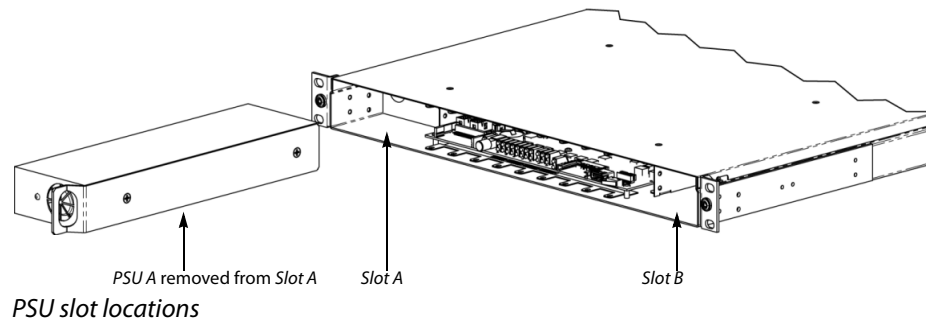

Two PSUs installed in a frame; front cover removed

Removing a Power Supply

To remove a power supply

- 1 Open the front cover of the frame and locate the power supply (PSU) you would like to remove (either the left or the right side).
- 2 Pull on the handle on the right side of the PSU and pull the PSU out of the frame.

Installing a Power Supply

To install a power supply

- 1 Position the power supply (PSU) in front of an empty power supply slot in front of the frame, with the connector end towards the frame and the PSU handle on the right side.
- 2 Slide the PSU into the empty slot, moving it gently until it contacts the sockets at the rear of the slot.
- 3 Push firmly but gently on the PSU faceplate until the PSU's connectors have mated with the frame's sockets, and the PSU will go in no further.

Powering up the Kaleido-X16

Separate AC power sockets serve the two power supplies. On the rear of the frame, connect both power sockets of the Kaleido-X16 to an appropriate power source using the supplied power cords.

As seen from the rear of the frame:

- The left power socket is for PSU B.
- The right power socket is for PSU A.

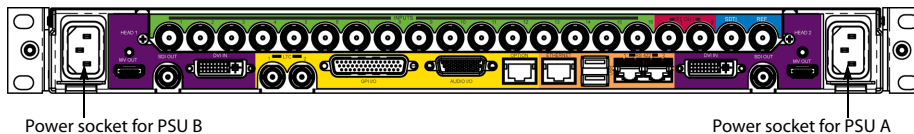

IMPORTANT

- A Kaleido-X16 multiviewer can draw 4.0 amps of current. Ensure that the circuit to which the frame is connected can handle that load, and that of any other connected devices.
- If you only have one PSU, make sure you plug your power cable into the power connector on the right side of the rear connector panel (as you face the rear of the frame). This should be on the same side of the frame as the one PSU you have installed. If you do not do this, your system cannot draw power.
- If you have two PSUs, make sure you plug in both power cables into both power connectors of the rear connector panel. If you do not do this your system cannot have PSU redundancy.

To power up the Kaleido-X16

- 1 Plug the power cord(s) from the Kaleido-X16 into a grounded power outlet.
- 2 Push the power button at the front of the frame (behind the front cover).

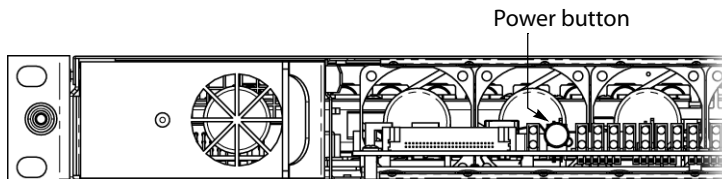

The startup sequence takes a couple of minutes, during which time some video may appear on the displays. The startup is completed when the CPU LED is solid green.

Ventilation

The Kaleido-X16 multiviewer is cooled by ventilation intakes located on the front of the frame. Fans are located in key positions within the frame:

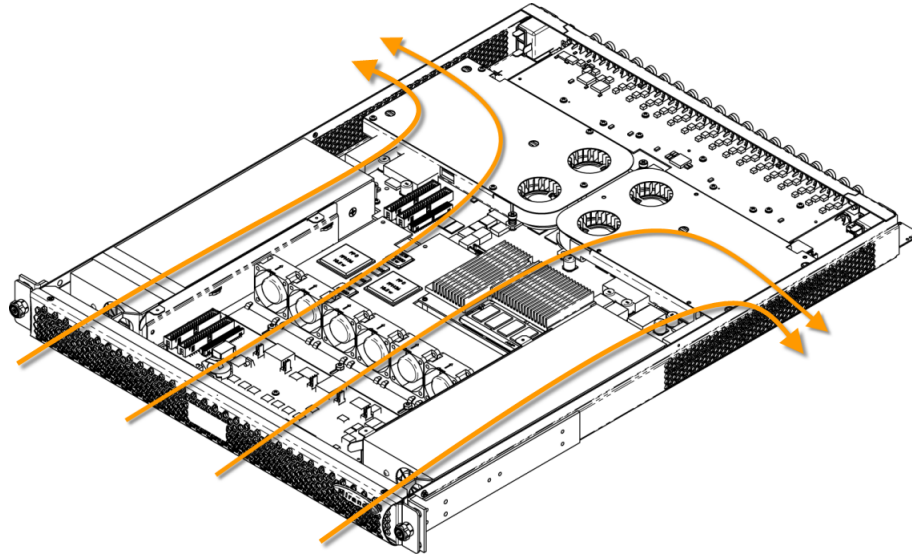

Air flow through the Kaleido-X16 frame

Frame Cooling Fans

Air intake for the multiviewer is handled by six fans located near the front of the frame and two heat sinks near the rear of the frame. The fans draw air into the frame through a grille and filter in the front cover. The heat sinks help to exhaust air out through grates on either side (see diagram, above).

IMPORTANT

The Kaleido-X16 multiviewer requires a constant flow of cooling air during operation. DO NOT OPERATE THE UNIT IF THESE FANS ARE NOT WORKING. If a fan is not working contact your next level of support.

Power Supply Cooling Fan

Each PSU has one fan located on its front. Each PSU draws air through the frame's front grille, through the PSU, then out to the closest rear fan to be exhausted out the side of the frame (see diagrams, above and below):

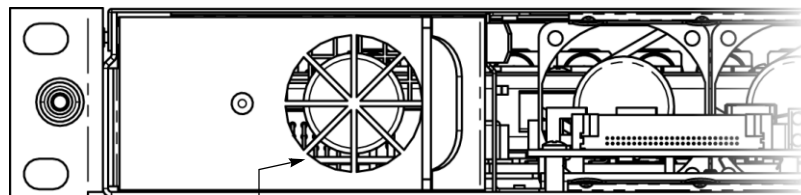

PSU fan on front of PSU A

Air Filter

Cooling air drawn into the Kaleido-X16 frame by the ventilating fans passes through a filter located behind a grille in the front cover of the frame.

For more information about cleaning the air filter, see [Cleaning the Air Filter](#), on page 21.

CompactFlash

In order to boot the CPU, you must ensure the appropriate CompactFlash (CF) card is properly inserted in the CF slot (accessible from the front of the Kaleido-X16 frame). The CF card contains the operating system required for a system boot.

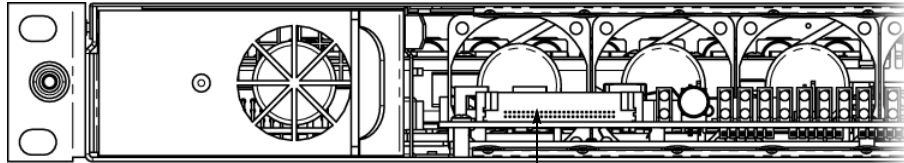

CF slot on front of Kaleido-X16 frame

For more information about starting the Kaleido-X16, see the *Setting up the Kaleido-X16* chapter in the Kaleido-X16 Quick Start Guide.

Signalling

IMPORTANT

The Kaleido-X16-D model supports two Heads while the Kaleido-X16-S supports one Head. For details about the difference in connector support on the two models, see [Kaleido-X16-D](#), on page 3 and [Kaleido-X16-S](#), on page 3.

Connector label	Connector type	Function
DVI IN1-2	DVI	DVI input signal that can be used as a background in the monitor wall display in place of the internally-generated background.
INPUTS 1-16	BNC	HD/SD-SDI or composite video inputs 1 to 16.
MV OUT 1-2	HDMI	HDMI output including embedded audio for each head.
SDI OUT 1-2	BNC	Serial digital HD output signal for monitoring purposes.
REF	BNC	Reference signal to genlock the multiviewer to the local plant. Supported Reference formats: <ul style="list-style-type: none"> • SMPTE ST 170 • SMPTE ST 318 • ITU 624-4 • BUT 470-6 • PAL and NTSC composite sync • SMPTE ST 274 • SMPTE ST 296 • SMPTE ST 240
LTC 1-2	BNC	Time code inputs.
GPI 1-44	DB-44 (female)	GPI input/output (unidirectional) connections.
RT OUT 1-2	BNC	Supports 3Gbps-SDI, HD-SDI, and SD-SDI router output signals.

Connector label	Connector type	Function
AUDIO I/O	HD-26 (female)	Supports two AES3 audio outputs or two analog audio outputs for monitoring.
SDTI	BNC	Multiplexed audio from an external audio box (Audio Bridge Terminal).
ETHERNET	RJ-45	100 Base-T Ethernet connection.
USB	USB	Connect a mouse, keyboard, or USB flash memory for software upgrade or data backup. Note: There are three USB ports, one on the front of the frame (behind the front cover) and two on the rear connector panel.
RS-422	RJ-45 (see RS-422 , on page 20)	Connect to an RS-422 (SMPTE ST 207, EBU-3245) or RS-485 device or network.

Inputs

Video Signals

The 16 BNC *Input* connectors located on the Kaleido-X16 frame's rear connector panel support HD/SD/3 Gbps SDI or composite video inputs 1 to 16 (see [Video Signal Inputs](#), on page 23 for specification details).

BNC connectors (16) for SD-SDI, HD-SDI, 3Gbps-SDI, and Analog Composite Inputs

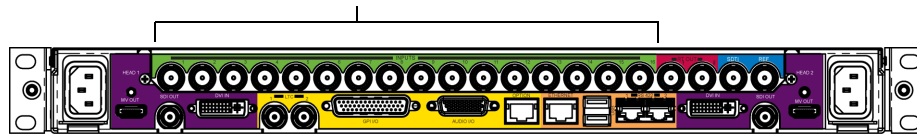

Graphic Signals

The Kaleido-X16-D supports two digital DVI inputs, one for each of two heads (the Kaleido-X16-S supports a single DVI input). The DVI IN connectors on the rear panel are female, dual-link DVI-I universal connectors. The supported signal and cabling for this connection is single-link DVI-D (see [DVI Graphic Inputs](#), on page 24 for specification details).

Note: The two DVI inputs cannot be crossed nor combined. That is, DVI IN 1 must output on Head 1, and DVI IN 2 must output on Head 2.

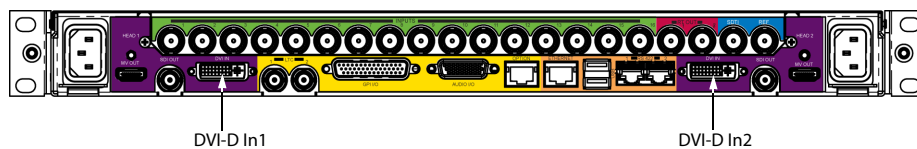

Mosaic Outputs

HDMI Outputs

There is one HDMI output for each output head (MV OUT 1, MV OUT 2). See [HDMI Outputs](#) on page 25 for specification details. The HDMI connection is a high definition connection for the multiviewer output, which carries audio and video, and can support resolutions up to 1920 × 1200.

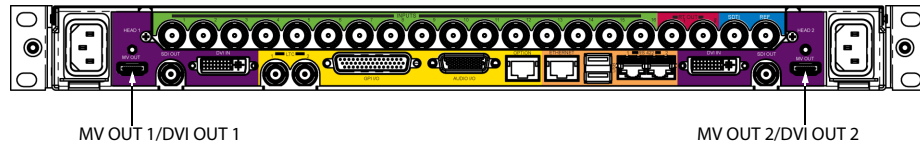

Note: To use an HDMI output connection as a DVI output, use an HDMI cable with an HDMI-to-DVI adapter at one end. Alternatively, use an HDMI-to-DVI cable.

HD-SDI Monitoring Outputs

IMPORTANT

Audio monitoring at the HD-SDI outputs is supported on recent hardware only.

Support for audio monitoring at the HD-SDI outputs requires **version 5.30** (or later) of the Kaleido-X Software, and recent hardware. In the XAdmin Status and Options page, under SYSTEM, the value indicated for the **Card revision** attribute must be **0x4** or more.

There are two HD-SDI monitoring outputs: one for each head (see [HD-SDI Monitoring Outputs](#), on page 26 for specification details).

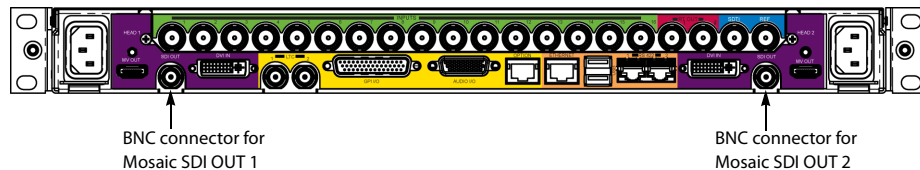

External Reference

The external reference (REF) input signal allows the Kaleido-X16 to genlock to the local plant.

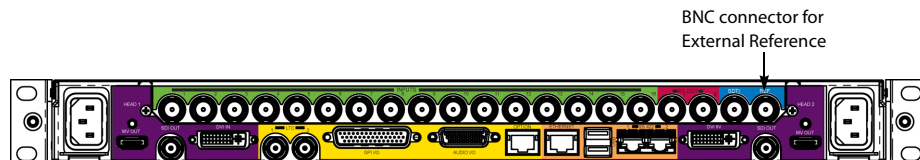

Router Outputs

The Kaleido-X16 can be configured as a router. In this configuration, up to two Kaleido-X16 channels are considered as sources, and the destinations are the two RT OUT ports on the rear connector panel:



For more information about Router Output specifications, see [Router Outputs](#), on page 27. For more information about Routers and the Kaleido-X16, see the *Routers* chapter of the Kaleido-X User's Manual.

Audio I/O

The Kaleido-X16 supports audio monitoring through its HD-26 connector. The supported formats are AES3 digital audio, and analog audio. In addition, the Kaleido-X16 supports audio monitoring through the SDTI input port from an audio bridge terminal (ABT).

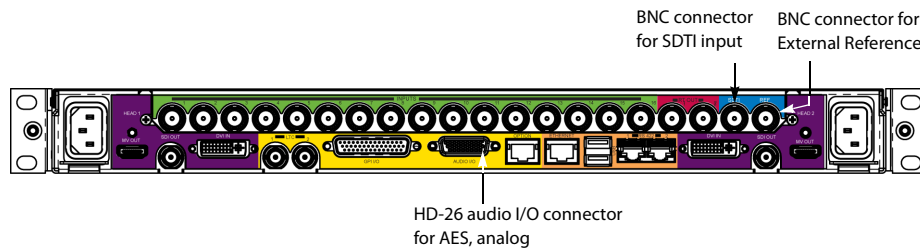

Audio I/O TBA

To facilitate cabling through the HD-26 connector, a terminal block adapter (TBA) is available separately (order code NSH26M).

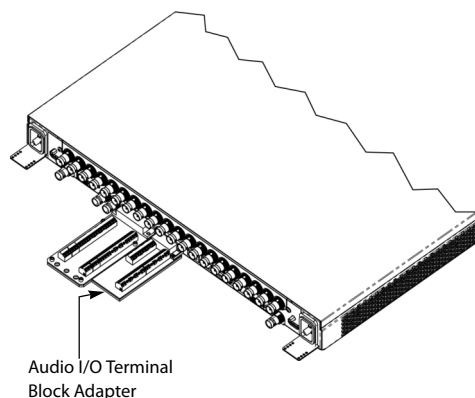

Audio I/O Terminal Block Adapter installed in rear connector panel

The pinout of the Audio I/O terminal block adapter (TBA) depends on whether you have a single-head or dual-head Kaleido-X16 model.

Audio I/O TBA Pinout on the Kaleido-X16-D

The Audio I/O TBA pinout on the Kaleido-X16-D is as follows:

Bottom row		Center row		Top row	
19	GND	10	AES Out 1 (+)	1	AES Out 1 (-)
20	GND	11	AES Out 2 (+)	2	AES Out 2 (-)
21	GND	12	GND	3	GND
22	GND	13	Analog Left Out 1 (+)	4	Analog Left Out 1 (-)
23	GND	14	Analog Right Out 1 (+)	5	Analog Right Out 1 (-)
24	GND	15	Analog Left Out 2 (+)	6	Analog Left Out 2 (-)
25	GND	16	Analog Right Out 2 (+)	7	Analog Right Out 2 (-)
26	GND	17	PC In 1 Left (<i>not supported</i>)	8	PC In 1 Right (<i>not supported</i>)
		18	PC In 2 Left (<i>not supported</i>)	9	PC In 2 Right (<i>not supported</i>)

Audio I/O TBA Pinout on the Kaleido-X16-S

The Audio I/O TBA pinout on the Kaleido-X16-S is as follows:

Bottom row		Center row		Top row	
19	GND	10	AES 1 (+)	1	AES 1 (-)
20	GND	11	NC	2	NC
21	GND	12	GND	3	GND
22	GND	13	Analog Left Out 1 (+)	4	Analog Left Out 1 (-)
23	GND	14	Analog Right Out 1 (+)	5	Analog Right Out 1 (-)
24	GND	15	NC	6	NC
25	GND	16	NC	7	NC
26	GND	17	PC In 1 Left (<i>not supported</i>)	8	PC In 1 Right (<i>not supported</i>)
		18	NC	9	NC

For more information about:

- SDTI audio specifications, see [SDTI Audio Input](#), on page 28.
- analog audio specifications, see [Analog Audio Output](#), on page 28.
- AES output specifications, see [AES Outputs](#), on page 28.
- triggering audio monitoring, see “Triggering Audio Monitoring” in the *Operation of the Monitor Wall* chapter of the Kaleido-X User’s Manual.
- calibrating audio monitoring delay, see “Calibrating the Audio Monitoring Delay” in the *Calibrating the Kaleido-X* chapter of the Kaleido-X User’s Manual.
- calibrating audio monitoring color, see “Calibrating the Audio Monitoring Color” in the *Calibrating the Kaleido-X* chapter of the Kaleido-X User’s Manual.

Control

The connectors located in the middle of the rear connector panel (the yellow and orange color-coded area) are *Control* connectors.

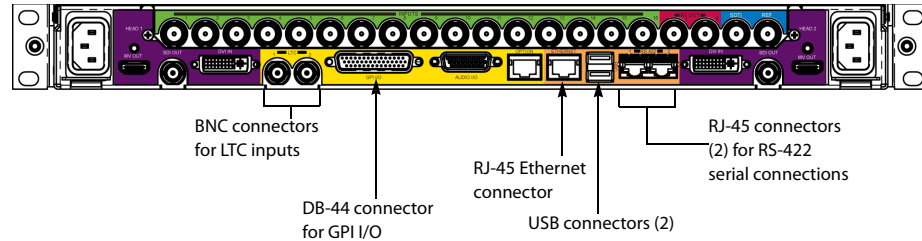

Linear Time Code (LTC)

The Kaleido-X16 supports two linear time code (LTC) inputs over BNC connectors. The format is SMPTE ST 12 unbalanced (see [Time Code Inputs \(LTC\)](#), on page 28 for specification details).

GPI I/O

The Kaleido-X16 supports status monitoring, genlock and GPI interfacing. The rear connector panel houses all input and output connectors associated with GPI I/O. The Kaleido-X16 supports 32 GPI inputs and 4 GPI outputs. The GPI connector type is a DB-44 (female on the connector panel; male on the cable):

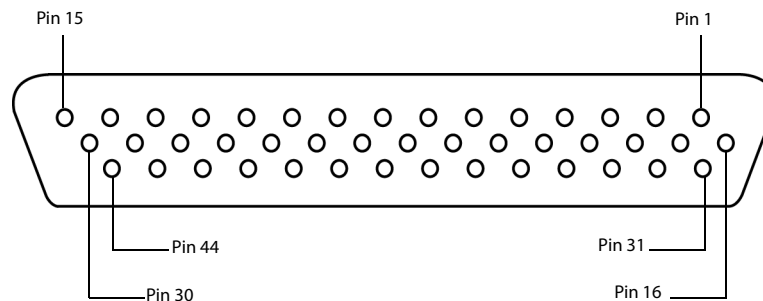

There are 44 GPI connector pins (40 not including GND) whose functions are as follows:

- 4 Ground (GND) pins
- 32 GPI Input pins
- 4 GPI Output Emitter pins (designated in the table, below, as "N")
- 4 GPI Output Collector pins (designated in the table, below, as "P")

The exact pinout for the GPI connector is as follows:

Bottom row		Middle row		Top row	
Pin #	Description	Pin #	Description	Pin #	Description
31	GND	16	GPI Output N 1	1	GPI Output P 1
32	GPI Output N 2	17	GPI Output P 2	2	GPI Output N 3
33	GPI Output P 3	18	GPI Output N 4	3	GPI Output P 4
34	GPI Input 21	19	GPI Input 22	4	GPI Input 23

Bottom row		Middle row		Top row	
Pin #	Description	Pin #	Description	Pin #	Description
35	GND	20	GPI Input 24	5	GPI Input 25
36	GPI Input 26	21	GPI Input 27	6	GPI Input 28
37	GPI Input 29	22	GPI Input 30	7	GPI Input 31
38	GPI Input 20	23	GPI Input 32	8	GPI Input 18
39	GPI Input 16	24	GPI Input 19	9	GPI Input 15
40	GPI Input 14	25	GPI Input 17	10	GPI Input 12
41	GND	26	GPI Input 13	11	GPI Input 10
42	GPI Input 9	27	GPI Input 11	12	GPI Input 7
43	GPI Input 6	28	GPI Input 8	13	GPI Input 4
44	GPI Input 3	29	GPI Input 5	14	GPI Input 1
		30	GPI Input 2	15	GND

GPI Circuits

The individual GPI contacts are reconfigurable as either inputs or outputs. For interfacing purposes, the input and output circuit configurations are as shown in the following diagrams:

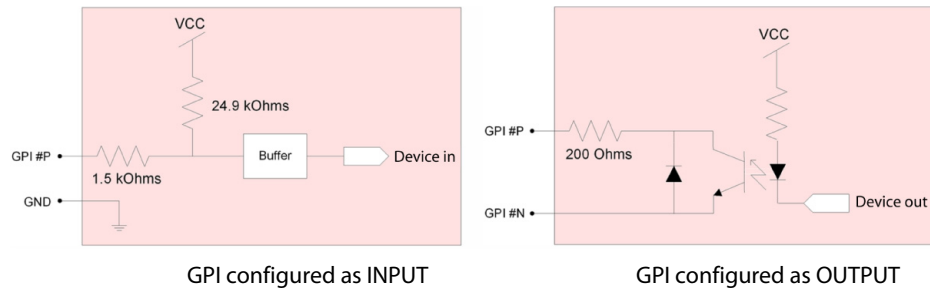

You should ensure your GPI physical connections are well established. In the following example, the goal is to trigger a relay and light up a light.

CAUTION

In the example, below, make sure your P and N connections are in the proper polarity otherwise your GPI output will always be in the ON state.

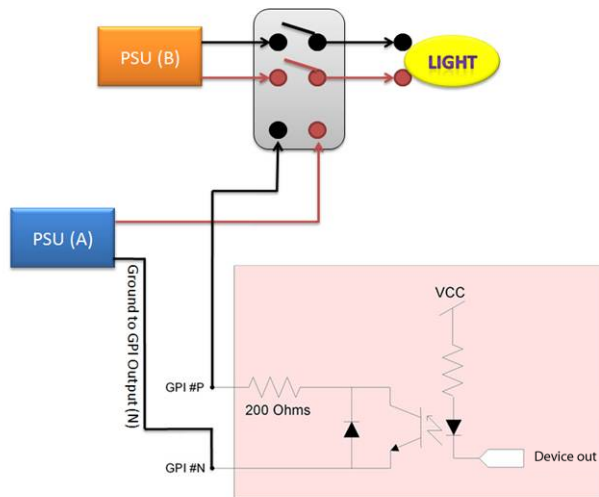

To facilitate cabling of the GPI inputs and outputs, a terminal block adapter is available separately (order code KXA-TBA-44). The GPI Terminal Block Adapter accommodates up to 44 terminal block connections using positive and negative terminal connections. Each column on the terminal block has 6 positive and 6 negative terminal connections that correspond to each pin position. Negative pins (labelled with an N) on the Terminal Block Adapter are not used as connections. Positive pins (labelled with a P) and Ground pins (labelled with a GND) correspond to GPI input connections:

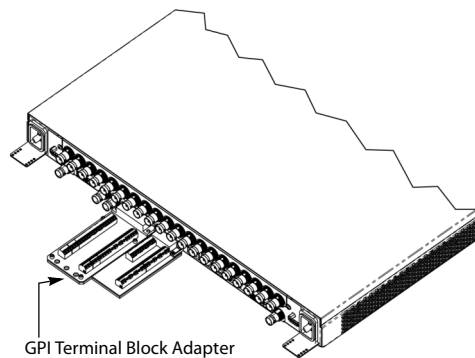

GPI Terminal Block Adapter installed in rear connector panel

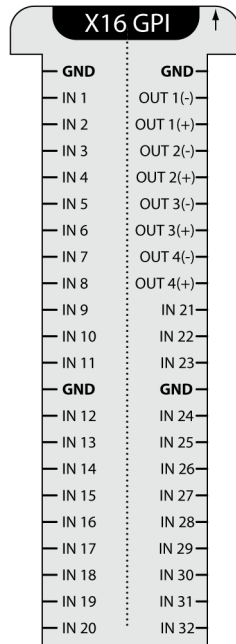

Kaleido-X16 GPI Terminal Block Adapter pinout

For more information about:

- GPI specifications, see [GPI INPUT \(up to 32\)](#) and [GPI OUTPUT \(up to 4\)](#), on page 29.
- triggering GPI output events, see “Triggering GPI Output Events” in the *Operation of the Monitor Wall* chapter of the Kaleido-X User’s Manual.
- calibrating GPI lines, see “Calibrating GPI Lines” in the *Calibrating the Kaleido-X* chapter of the Kaleido-X User’s Manual.

Ethernet

The Kaleido-X16 supports one Ethernet connection through an RJ-45 connector (see [Ethernet](#), on page 29 for specification details).

USB

The Kaleido-X16 has three USB 1.0 connectors (see [USB](#), on page 29 for specification details). Connect a mouse, keyboard, or USB flash memory for a software upgrade or data backup. Two connectors are on the rear connector panel, and one is on the front of the frame behind the front cover.

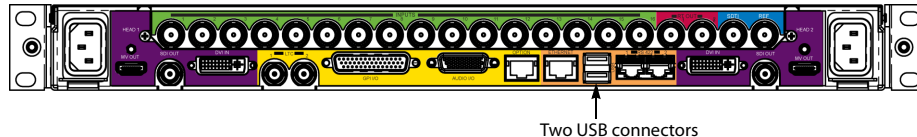

Two USB connectors on the rear panel

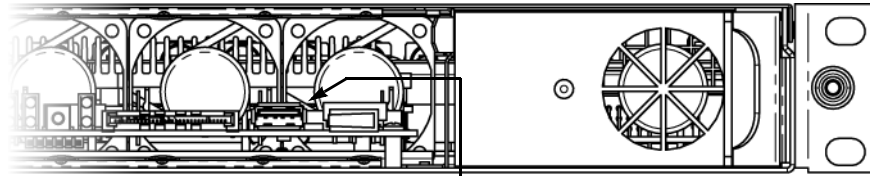

USB (1) connector on front of Kaleido-X16

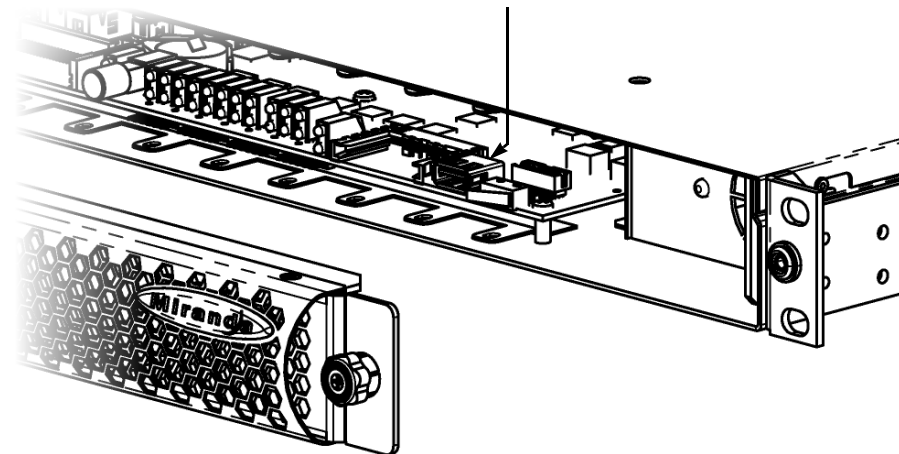

One USB connector on the front of the frame

RS-422

The Kaleido-X16 supports two RS-422 serial inputs over RJ-45 connectors. These inputs allow the Kaleido-X16 to connect to external serial devices such as a router, production switcher, or router controller.

Note: The Kaleido-X16's two RS-422 ports each have an RJ-45 connector in order to preserve space on a busy panel. The RS-422 interface specifies a DE-9 connector, so if you are using this interface, you will require a DE-9-to-RJ-45 adapter. Grass Valley supplies two adapter models, correctly wired for this application: a straight adapter (part no. 1737-3000-102), and a crossover adapter (part no. 1792-3700-100).

The pinout for the RS-422 signals on the Kaleido-X16's RJ-45 connectors, and the wiring diagrams for the appropriate adapters, are shown here:

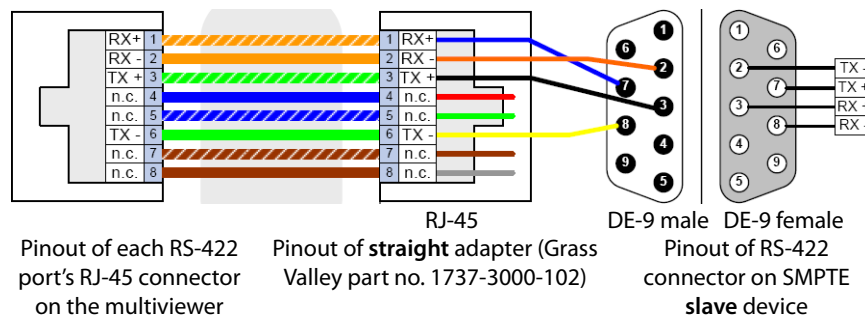

Standard wiring between multiviewer and devices wired to SMPTE "slave" specification (e.g. most routers, Ross Synergy switchers, Nevion ETH-CON)

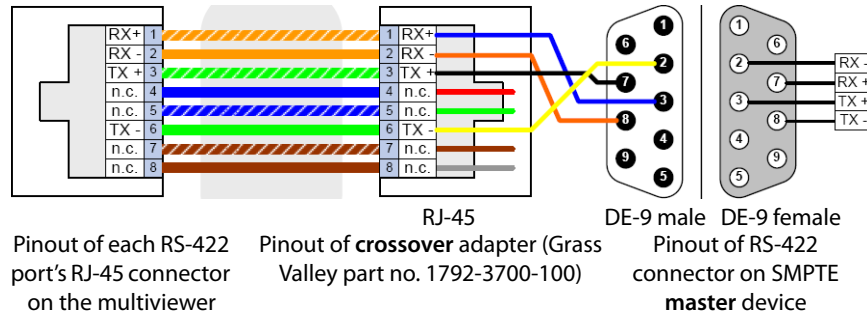

Standard wiring between multiviewer and devices wired to SMPTE "master" specification (e.g. Philips Jupiter router control system, Miranda Presmaster PCS)

Note: The two RS-422 ports on the Kaleido-X16 side have no ground pin. Using the appropriate DE-9S-to-RJ-45 adapter, an external device should be able to communicate with a Kaleido-X16 despite the lack of a ground.

For more information about RS-422 specifications, see [RS-422](#), on page 29. For more information about RS-422 serial connections, see "Serial Connections" in the "Routers" chapter of the Kaleido-X User's Manual.

Maintenance

Cleaning the Air Filter

Occasionally, the air filter has to be cleaned in order to maintain proper ventilation. The air filter is located in the front cover of the Kaleido-X16 frame. The filter may be cleaned without removing it from the cover.

To clean the air filter

- 1 Carefully remove the cover from the frame.

IMPORTANT

Risk of damage to CompactFlash card

Be careful not to damage the CompactFlash card as you remove the front cover of the frame. Lift the cover directly away from the frame (i.e.: not up or down).

- 2 Place the cover flat on a work surface with the inside facing up.
- 3 Using a vacuum cleaner with a brush nozzle to prevent scratching, vacuum the dust from the inner side of the cover.
- 4 Turn the cover over and vacuum the outer side of it.
- 5 Reinstall the cover onto the frame.

Replacing a Defective Power Supply

In the event of a power supply failure, the unit will switch to the redundant power supply for its power source. If a PSU's LED is not green, you must replace the unit.

For more information about removing and reinstalling a power supply, see [Power Supplies](#), on page 7.

2 Specifications

This chapter lists equipment specifications for the Kaleido-X16 multiviewer.

Inputs

Video Signal Inputs

The Kaleido-X16 frame supports 16 signal inputs. The supported input types include Composite, SD/SDI, HD-SDI, and 3Gbps (auto-detected). The processing delay is two fields if the video inputs are genlocked, and two or three fields if the video inputs are not genlocked. Signal inputs require BNC connectors.

Composite Inputs

Signal	NTSC (SMPTE ST 170), NTSC-J, PAL-BGDHI, PAL-N, PAL-M, SECAM
Return loss	> 30 dB up to 5.75 MHz
Quantization	8 bits

SD-SDI Inputs

Signal	4:2:2 SMPTE ST 259-C (270 Mbps)
Formats	525 and 625
Audio	SMPTE ST 274:1994
Cable length	225 m (738 ft) (Belden 1694A)
Return loss	>15 dB up to 270 MHz
Jitter	< 0.2 UI

HD-SDI Inputs

Signal	4:2:2 SMPTE ST 292-C (1.5 Gbps)
--------	---------------------------------

HD-SDI Inputs *(continued)*

Formats	720p24, 720p25, 720p29.97, 720p50, 720p59.94 1080i50, 1080i59.94 1080PsF23.98, 1080PsF24, 1080PsF25, 1080PsF29.97 1080p23.98, 1080p24, 1080p25, 1080p29.97 Note: The Kaleido-X software does not distinguish between 1080PsF25 and 1080i50, and neither between 1080PsF29.97 and 1080i59.94. Both 1080PsF25 and 1080i50 are reported as 1080i50, and both 1080PsF29.97 and 1080i59.94 are reported as 1080i59.94, on the monitor wall and in XAdmin's Status and Options page.
Audio	SMPTE ST 299-1
Return loss	>15 dB up to 1.485 GHz
Jitter	< 0.2 UI
Cable length	100 m (328 ft) (Belden 1694A)

3Gbps Inputs

Signal	4:2:2 SMPTE ST 424:2006 (2.97/1.001 Gbps)
Formats	1080p50 1080p59.94
Audio	SMPTE ST 299-1
Return loss	> 15 dB up to 1.485 GHz > 10dB up to 2.97GHzB
Jitter	< 0.2 UI
Cable length	100 m (328 ft) (Belden 1694A)

Graphics converted to HD-SDI from KXI-DVI-Bridge

Signal	SMPTE ST 292-C (1.485, 1.485/1.001 Gbps)
Formats	1024 × 768 @ 60 (XGA) 1280 × 1024 @ 60 (SXGA) 1366 × 768 or 1368 × 768 @ 60 (WXGA) 1680 × 1050 @ 60 (WSXGA+) 1600 × 1200 @ 60 (UXGA)
Cable length	100 m (328 ft) (Belden 1694A)

DVI Graphic Inputs

The Kaleido-X16 supports two DVI inputs, one for each of two output heads.

Signal	DVI-D (single link)
Resolution	From 1024 × 768 to 1920 × 1200 NI

H frequency	37 kHz to 96 kHz
Refresh rate	50/59.94 Hz
Cable length	3.6 m (12 ft) with Altinex CB4012DV
Connector	DVI-I (dual link)

Outputs

Mosaic Outputs

The Kaleido-X16 frame supports two HDMI outputs.

HDMI Outputs

Signal	DVI-D
Resolution	From 1024 × 768 to 1920 × 1200 NI
H frequency	37 kHz to 96 kHz
Refresh rate	50/59.94 Hz
Cable length	5 m (15 ft) ¹
Connector	HDMI
Supported cable types	HDMI to HDMI, or HDMI to DVI-D

1. Depending on the selected output resolution, on your display monitor's tolerance, and on the quality of the HDMI cable itself, a longer cable could be used, as long as the signal integrity is maintained between the multiviewer, and the display monitor. For example, with a 1080p output resolution, longer high-speed HDMI cables may require an HDMI booster.

The following table lists some (but not all) output formats supported on the HDMI connection.

Resolution	Format name	Refresh rates (Hz)
1024 × 768	XGA	50.00, 59.94
1280 × 720	Margay	50.00, 59.94
1280 × 768	WXGA	50.00, 59.94
1280 × 1024	SXGA	50.00, 59.94
1280 × 1024	Barco	59.94
1360 × 768	NEC	50.00, 59.94
1480 × 1200	Christie	50.00, 59.94
1600 × 1200	UXGA	50.00, 59.94
1920 × 1080	Baycat	50.00, 59.94
1920 × 1200	WUXGA	50.00, 59.94

Note: Users can customize their own timing rates through the XEdit software for resolutions ranging from 1024 × 768 up to 1920 × 1200 pixels.

The Kaleido-X16 frame supports two 3G/HD-SDI monitoring outputs (with embedded audio).

HD-SDI Monitoring Outputs

Signal	4:2:2 SMPTE ST 292-C (1.5 Gbps)
Formats	720p59.94 1080i50 1080i59.94 1080PsF23.98 1080PsF24 1080PsF25 1080p23.98 β 1080p24 1080p29.97
Audio	SMPTE ST 299-1 (limited to one pair, embedded on group 1, pair 1)
Cable length	100 m (328 ft) (Belden 1694A)
Jitter	< 0.2 UI p-p
Connectors	BNC

3G-SDI Monitoring Outputs

Signal	4:2:2 SMPTE ST 424:2006 (2.97 Gbps / 2.97/1.001 Gbps)
Formats (Level A only)	1080p50 1080p59.94
Audio	SMPTE ST 299-1 (limited to one pair, embedded on group 1, pair 1)
Cable length	100 m (328 ft) (Belden 1694A)
Return loss	> 15 dB up to 1.5 GHz > 10 dB up to 2.97 GHz
Quantization	8 bits
Jitter	< 0.3 UI p-p
Connectors	BNC

Router Outputs

The Kaleido-X16 frame supports two 3G/HD/SD-SDI router outputs.

SD-SDI Router Outputs

Signal	4:2:2 SMPTE ST 259-C (270 Mbps), SMPTE ST 272:1994
Formats	525 and 625
Cable length	225 m (738 ft) (Belden 1694A)
Return loss	>15 dB up to 270 MHz
Additive jitter	< 0.2 UI p-p (wideband)
Connector type	BNC

HD-SDI Router Outputs

Signal	4:2:2 SMPTE ST 292-C (1.5 Gbps)
Formats	720p59.94 1080i50 1080i59.94 1080PsF23.98 1080PsF24 1080PsF25 1080PsF29.97 1080p23.98 1080p24 1080p29.97
Cable length	100 m (328 ft) (Belden 1694A)
Return loss	>15 dB up to 1.5 GHz
Additive jitter	< 0.2 UI p-p (wideband)
Connector	BNC

3G-SDI Router Outputs

Signal	4:2:2 SMPTE ST 424:2006 (2.97 Gbps / 2.97/1.001 Gbps)
Formats	1080p50 1080p59.94
Cable length	100 m (328 ft) (Belden 1694A)
Return loss	>15 dB up to 1.5 GHz + 10 dB up to 2.97 GHz
Jitter	< 0.3 UI p-p (wideband)
Connectors	BNC

Audio I/O

The Kaleido-X16 frame supports one SDTI audio input.

SDTI Audio Input

Signal	SMPTE ST 305 (up to 128 channels/64 AES)
Cable length	250 m (820 ft) (Belden 1694A)
Connector	BNC

The Kaleido-X16 supports audio monitoring through its HD-26 connector. The supported formats are the AES3 digital audio, and analog audio.

Analog Audio Output

Signal	Balanced analog audio
Level	MAX + 24 dBu
Quantization	20-24 bits
Impedance	< 600 Ω
THD+N	80 dB
SNR	92 dB
Connector	HD-26

AES Outputs

Signal	Balanced digital audio
Format	AES3
Level	4 V p-p
Impedance	110 Ω
Connector	HD-26

Control

The Kaleido-X16 frame supports two LTC unbalanced inputs for clock synchronization.

Time Code Inputs (LTC)

Signal	SMPTE ST 309:1999, SMPTE ST 12:1995(EBU-3259-E)
Electrical level	0.3 to 5 V p-p
Impedance	High Impedance (>10k Ω)
Connector	BNC

The Kaleido-X16 supports 32 GPI inputs and 4 GPI outputs, on a DB-44 female connector.

GPI INPUT (up to 32)

Description	Contact closure to GND
Pull-up voltage	3.3 Volts
Source current	30 μ A when input shorted
Low-level activation	0.8 Volts max
Over voltage	24 Volts max
Connector	DB-44

GPI OUTPUT (up to 4)

Description	Contact closure to GND
Signal	Open collector 5 to 12 VDC
Contact closure current	50 mA max
Reverse voltage	-15 Volts max
Reverse current	-50 mA max
V out low	0.6 Volts at 1.5mA
Connector	DB-44

Ethernet

Signal	10/100 BASE-T (IEEE 802.3)
Connector	RJ-45

RS-422

Signal	RS-422 (SMPTE ST 207, EBU-3245)
Connector	RJ-45

USB

Signal	USB Version 1.0
Connector	USB

Frame

Power supply	Hot-swappable redundant power supply
Input voltage	100-240 V
Frequency	47.63 Hz
Power	300 W @ 75% of PSU

Specifications
Frame

Max current	4 A
Max power	300 W
Dimensions	H: 45 mm (1.75 in) (1 RU) W: 451 mm (18 in) + mounting flange for standard 19-inch rack D (with cover and connectors): 641 mm (25.25 in) D (without cover and connectors): 591 mm (23.25 in)
Full spec. temp. range	0-40 °C (ambient)
Storage humidity	90% RH non-condensing
Functional humidity	65% RH non-condensing
Weight (2 PSUs)	10.5 kg (23 lbs)
Weight (1 PSU)	9.5 kg (21 lbs)

Disposal and Recycling Information



Your Grass Valley equipment comes with at least one lithium button battery (Li-MnO₂) located on the main printed circuit board. The batteries are used for backup and should not need to be replaced during the lifetime of the equipment.

Before disposing of your Grass Valley equipment, please remove the battery as follows:

- 1 Make sure the AC adapter is unplugged from the power outlet.
- 2 Remove the protective cover from your equipment.
- 3 Gently remove the battery from its casing using a blunt instrument for leverage such as a screwdriver if necessary.

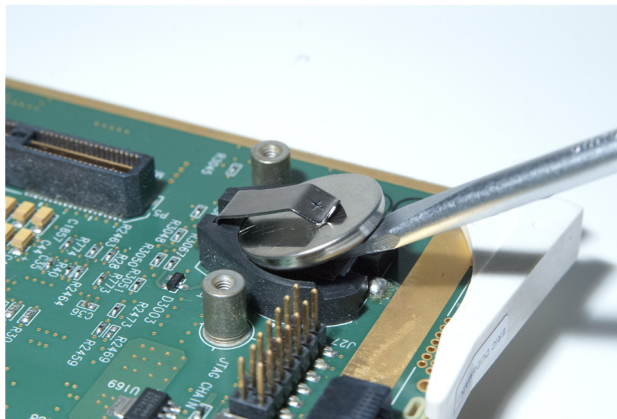

- 4 Dispose of the battery and equipment according to your local environmental laws and guidelines.

WARNING

Be careful not to short-circuit the batteries by adhering to the appropriate safe handling practices. Do not dispose of batteries in a fire as they may explode. Batteries may explode if damaged or overheated. Do not dispose of batteries as household waste. Do not dismantle, open or shred batteries. Keep batteries out of the reach of children.

The electrolyte of the batteries contains 1,2-dimethoxyethane (DME) (CAS 110-71-4, EINECS 203-794-9) above 0.1% by weight. DME is listed as a Substance of Very High Concern (SVHC) by the regulation (EC) No 1907/2006 of the European Parliament and of the Council. It is classified as a reprotoxic of category 2 in the European Union. Accordingly, exposure to DME may impair fertility and may cause harm to the unborn child. DME is also classified as harmful by inhalation.

WARNING *(continued)*

Risk of exposure occurs only if the battery is mechanically or electrically abused. The most likely risk is acute exposure when a cell vents. In the event of a battery leak, do not allow battery liquid to come in contact with skin or eyes. Seek medical help immediately in case of ingestion, inhalation, skin or eye contact, or suspected exposure to the contents of an opened battery.

For more information about recycling, please contact Grass Valley.



Grass Valley Technical Support

For technical assistance, contact our international support center, at 1-800-547-8949 (US and Canada) or +1 514 333 1772.

To obtain a local phone number for the support center nearest you, please consult the Product Support section of Grass Valley's Web site, at <http://www.grassvalley.com/support/contact>.

An online form for e-mail contact is also available from the Web site.

Corporate Head Office

Grass Valley
3499 Douglas-B.-Floreani
St-Laurent, Quebec H4S 2C6
Canada
Telephone: +1 514 333 1772
Fax: +1 514 333 9828
www.grassvalley.com