

# 401X QUAD

*Four Channel VHF Wireless  
Microphone System*



**OWNER'S MANUAL**

---

---

# C O N T E N T S

---

---

Introduction .....	3
System Features .....	4
Operation .....	5
• 401X Quad Receiver .....	5
• WHT Handheld Microphone Transmitter .....	8
• WLT Lavalier/Lapel or Headworn Microphone .....	10
• WGT Instrument Bodypack Transmitter .....	12
• LINK 2™ Plug-In Transmitter .....	14
Specifications .....	17
Service .....	18

---

---

# I N T R O D U C T I O N

---

---

Thank you for purchasing a Nady 401X Quad VHF Wireless Microphone System and congratulations on your choice. The 401X Quad VHF is by far the best price/performance value available in multiple channel wireless systems. Please read the instructions in this manual completely before operating your unit.

## ***Using This Manual***

This booklet provides instructions for the operation of the Nady 401X Quad four-channel VHF wireless, including handheld, instrument, lavalier, headmic and plug-in transmitter systems. Features of the 401X Quad are listed, followed by step-by-step instructions explaining how to operate your new system. After reading the receiver instructions, turn to the section of the booklet that covers the type of transmitter used with the system you have purchased. Each section will give you detailed operating instructions. Also included in this manual are system specifications and servicing information.

## ***401X Quad Receiver***

- Four independent VHF receivers in one convenient, rugged, all-metal single rack space housing – makes operating 4 wireless systems at the same time easier than ever
- Front-mount dual antenna jacks for either onboard or remote antennas
- Front panel Power ON/OFF switch, plus Power ON LED, TX ON and AF signal level LED displays
- Rear panel individual XLR AF Output jacks, volume and RF mute controls for each of the 4-channels, and 4-Channels-Mixed AF Out 1/4" phone jack
- Noise-free transmitter ON/OFF operation
- High performance – unmatched transparent audio with 120 dB dynamic range and up to 250+ feet optimum line-of-sight operation

## ***WHT Handheld Microphone Transmitter***

- Features the Nady DM -10D unidirectional neodymium dynamic cartridge for optimum true sound, maximum feedback rejection and minimal handling noise
- OFF/STANDBY/ON switch allows convenient audio muting with the transmitter "ON"
- Low battery LED indicator flashes once for unit "ON"; lights steady for low battery alert
- Rubber, "easy-mount" mic clip included

## ***WGT & WLT Bodypack Transmitters***

- Choice of instrument (WGT-15) or headworn/lavalier microphone (WLT-15) bodypack transmitter
- OFF/STANDBY/ON switch allows convenient audio muting with the transmitter "ON"
- Low battery LED indicator flashes once for unit "ON"; lights steady for low battery alert
- Locking 3.5mm mini-jack provides secure connection for removable microphone or instrument cable
- Easily accessible input level adjust control for optimum sound

## ***LINK 2™ Plug-In Transmitter***

- Plug-in transmitter converts your favorite XLR handheld or lavalier microphone to wireless instantly
- Rugged construction and positive locking connector for reliable performance
- Selectable phantom power and LO/HI audio input level
- Optional leatherette pouch with clip available for use as bodypack

## **401X Quad Receiver**

### ***1. Powering the Receiver***

Plug the **16V AC/DC ADAPTER (1)** provided into the **DC INPUT JACK (11)** on the back of the receiver. Then plug the power supply into an AC outlet.

*(Note: Any 16V DC source with 800mA capability can also be used.)*

Turn **VOLUME CONTROL (6)** for all four channels counterclockwise to minimum located on the front of the receiver. Once the receiver is connected to a power source, press the **POWER SWITCH (3)** to ON position. The **POWER ON LED (4)** indicator will light up. The **TX LED INDICATOR (7)** on the front panel of the receiver will not light up until one or more of the four channels is receiving a signal from your system's transmitter.

### ***2. Antennas***

The **ANTENNAS (2)** assembly consists of two antennas. Connect antennas into the **ANTENNA JACKS (5)** on the front of the receiver. Extend the antennas fully to obtain maximum range. Position **ANTENNAS (2)** at 45 degrees from the horizontal; 90 degrees from each other. For maximum range, it is always best to maintain a line of sight (no obstructions) between the receiver antennas and the transmitter whenever possible.

### ***3. Mute (Squelch) Adjustment***

In normal operation, the **MUTE CONTROL (9)** should be set fully counterclockwise to the factory preset minimum RF level of 1 $\mu$ V for maximum sensitivity. Doing so sets each receiver for maximum range. However, in areas of high RF activity, the mute (or squelch, as it is sometimes called) may need to be adjusted to compensate for the adverse conditions in a particular location. If, with the transmitter off, its corresponding LED on the receiver front panel flickers or stays on, the **MUTE CONTROL (9)** should be turned clockwise until the LED extinguishes. For each of the four channels, when the Mute is properly adjusted, the corresponding LED will light only when the system's transmitter is turned on. Turning the **MUTE CONTROL (9)** too far clockwise will result in reduced range, but yield a quieter signal during dropouts or at the end of the operating distance range.

### **5. Connecting the Audio Output**

The output stage of each channel and the separate four channels mixed output of the 401X Quad are all configured for adjustable unbalanced LINE and fixed balanced XLR line or microphone audio outputs. The adjustable unbalanced 1/4" mix out is a low level LINE with an output impedance of 600 ohms. The individual fixed level balanced XLR out can be configured as high level line out with 11k ohms output impedance or microphone level out with a 600 ohms load impedance.

For each channel you wish to use, insert an audio cord with a balanced female XLR plug into its **AF OUTPUT (10)** jack on back of the receiver. Plug the other end of each cord into your amplifier, effect or mixing board. Adjust volume on your mixing board so that no audio distortion is present when amp or mixer is set at its usual level.

*[Note: To prevent possible undesired noises during use, leave the volume controls of unused channels, (which the corresponding transmitter off) turned off in the amp or mixer. The audio should only be "live" if the transmitter is on.]*

If you want to use the 401X Quad as its own mixer (your amplifier, effect or mixing board should have 12dB or more gain select on), you can connect to the **MIX AF OUTPUT (8)** which provides a mixed line output of up to all four channels, with the relative volume of each channel in the mix determined by that channel's **VOLUME CONTROL (6)**.

#### ***a. Instrument Connection (using the WGT instrument transmitter)***

Insert an audio cord with a 1/4" mono phone plug in the **AF OUTPUT JACK (8)** on the rear panel of the receiver. Plug the other end of the cord into amplifier, effect or mixing board. Adjust the **VOLUME CONTROL (6)** on the 401X Quad clockwise to about 3/4 rotation until the volume level is comfortable for your application. This setting is roughly equivalent to direct instrument cord connection. Turning the volume up to maximum will provide 4dB gain over a cord.

#### ***b. Microphone Connection (using the WLT transmitter with either a headset or lavalier microphone or the WHT handheld microphone transmitter)***

Insert an audio cord with a 1/4" mono phone plug in the **AF OUTPUT JACK (8)** on the rear panel of the receiver. Plug the other end of the cord into amplifier, effect or mixing board. Adjust the **VOLUME CONTROL (6)** on the 401X Quad clockwise to about 1/2 MAX and adjust the volume control until the volume level is optimal. If the volume control is set too high, you may overload your mixer or amp.

Since your 401X Quad is comprised of four separate and independent XLR output channels, it can be used with either one, two, three or four channels operating. Simply turn your mixer volume control of any channel which you are not using to minimum. If the mix line out is used, just turn down the 401X Quad receiver's volume controls.

# OPERATION

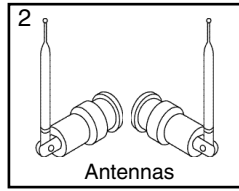
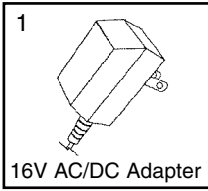

401X Quad Front

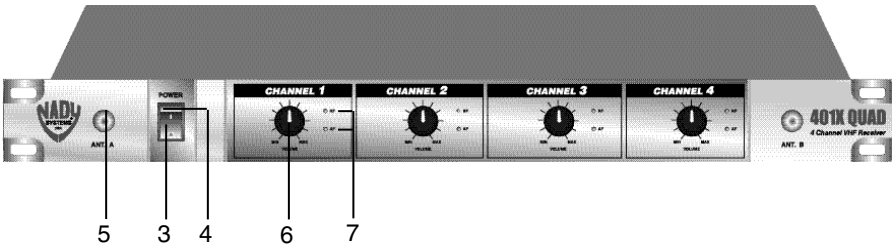

401X Quad Back

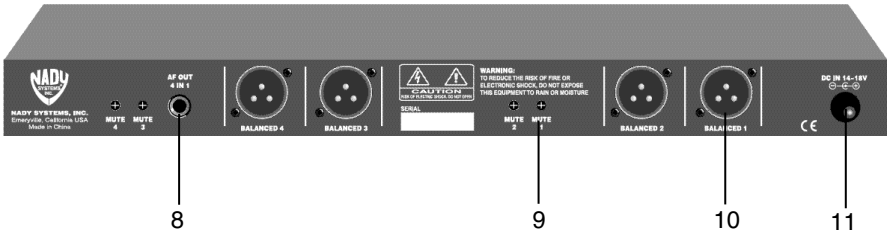

## ***WHT Handheld Microphone Transmitter***

1. Unscrew the **BATTERY COMPARTMENT COVER (12)** and remove, exposing the **BATTERY HOLDER (13)**. Insert a fresh **9V ALKALINE BATTERY (14)**, observing the correct polarity as marked, and screw the cover back on to the microphone. Make sure the cover is screwed on completely. A fresh alkaline battery can last up to 15 hours in use, but in order to ensure optimum performance, it is recommended that you replace the battery after every 10 hours of use.

2. Turn on the WHT by sliding the **OFF/STANDBY/ON SWITCH (15)** to the **STANDBY** position (transmitter on, audio muted) or the **ON** position (transmitter and audio both on). The **BATTERY INDICATOR LED (16)** will give a single quick flash, indicating usable battery strength. In the case of a dead or low battery, the LED will either not go on at all or will stay on continuously, indicating that the battery should be replaced with a fresh one. To preserve battery life, turn the transmitter off when not in use.

3. The microphone is now ready to use. The **TX LED INDICATOR (7)** on the 401X Quad receiver should now be lit, indicating a received signal from the transmitter. When ready to speak, slide the transmitter switch to the **ON** position. Adjust the volume of the receiver as per the Audio Output Microphone Connection section of the above 401X Quad receiver instructions. The **AF LEVEL LED DISPLAY (7)** on the 401X Quad receiver will light up as if the input signals are getting stronger. Occasional flickering on and off during use of the LED indicator is normal. However, if the LED stays on continuously, it means the signal is too loud and there is the possibility of overload distortion. If this occurs, back off from the microphone until the red LED indicator only flickers on peaks.

*[Note: Observe care in selecting P.A. volume, transmitter location and speaker placement so that acoustic feedback (howling or screeching) will be avoided.]*

*[Note: Microphone elements can easily be destroyed by the buildup of salts and minerals from perspiration and saliva. It is good practice to put a windscreen on the mic element at all times to protect it.]*



---

# OPERATION

---

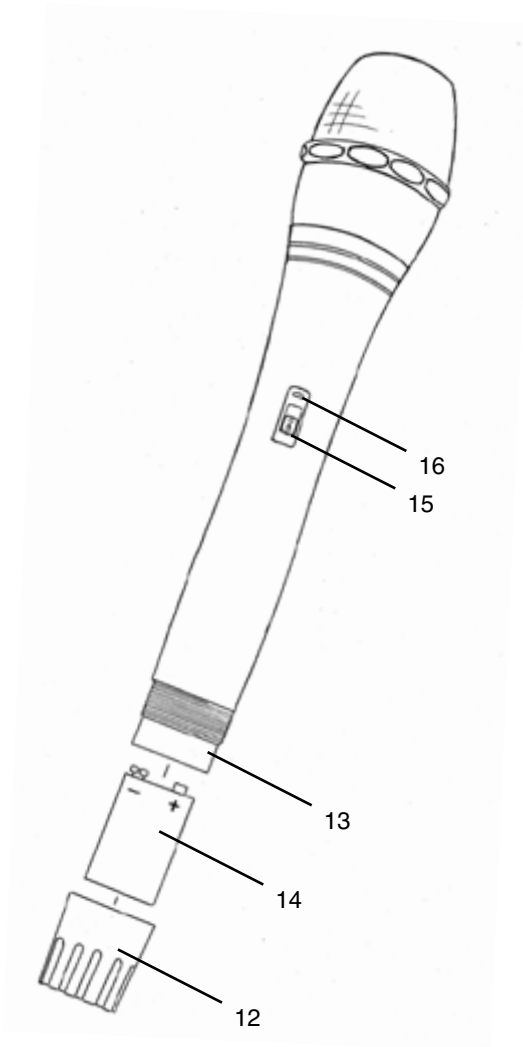

## **WLT Lavalier/Lapel or Headworn Microphone Bodypack Transmitter**

1. Snap open the **BATTERY COMPARTMENT (17)** and insert a fresh **9V BATTERY (18)**, observing the correct polarity. Close the compartment.

2. The WLT is provided with a 3.5 mm **LOCKING JACK (19)** for connecting the microphone. Plug in either the **LAVALIER/LAPEL (20)** or the **HEADWORN MICROPHONE (21)**, as supplied. To secure the connection, turn the metal slip ring on the plug clockwise to thread it on to the jack. To unplug, reverse the process. Slip the transmitter into a pocket or clip on to your clothes. To use the lavalier mic, attach it at chest level. Do not place too close to the mouth – a distance of about six inches usually works best. To use the headworn mic, place it on the head and adjust the mic boom so that the mic is about one inch to the side of the front of the mouth.

*(Note: The lavalier or headworn mic wire is also the transmit antenna, and rolling up or shortening the wire may reduce the effective operating range. Extend the wire fully during use and keep it as straight as possible.)*

3. Turn on the WLT by sliding the **OFF/STANDBY/ON SWITCH (22)** to the **STANDBY** position (transmitter on, audio muted) or the **ON** position (transmitter and audio both on). The **BATTERY INDICATOR LED (23)** will give a single quick flash, indicating usable battery strength. In the case of a dead or low battery, the LED either will not go on at all or will stay on continuously, indicating that the battery should be replaced with a fresh one.

4. The microphone is now ready to use. The **TX LED INDICATOR (7)** on the 401X Quad receiver should now be lit, indicating a received signal from the transmitter. When ready to speak, slide the transmitter switch to the **ON** position and adjust the volume of the receiver as per the Audio Output Microphone Connection section of the above 401X Quad receiver instructions. The **AF LEVEL LED DISPLAY (7)** on the 401X Quad receiver will light up as if the input signals are getting stronger. Occasional flickering on and off during use of the LED indicator in this display is normal, however if the LED stays on continuously, it means the signal is too loud and there is the possibility of overload distortion. Re-position the microphone farther from the source or adjust the **AUDIO INPUT LEVEL CONTROL (24)** until the red LED indicator flickers only on the loudest inputs.

*[Note: Observe care in selecting P.A. volume, transmitter location and speaker placement so that acoustic feedback (howling and screeching) will be avoided. Please also observe the pickup patterns of the microphone selected: omnidirectional mics pick up sound equally from all directions and are prone to feedback if not used carefully. Unidirectional mics are more resistant to feedback, but pick up sound sources best that are directly in front of the mic. Also, mics that are farther from the sound source, such as lavaliers, require more acoustic gain and thus are also more prone to feedback than close-source mics such as handheld or headworn mics that are used close to the mouth.]*

*(Note: Microphone elements can easily be destroyed by the buildup of salts and minerals from perspiration and saliva. It is good practice to put a windscreen on the mic element at all times to protect it.)*

# OPERATION

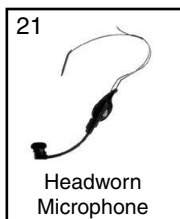
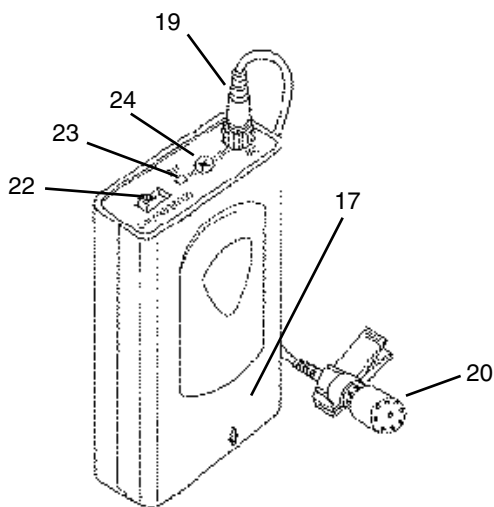
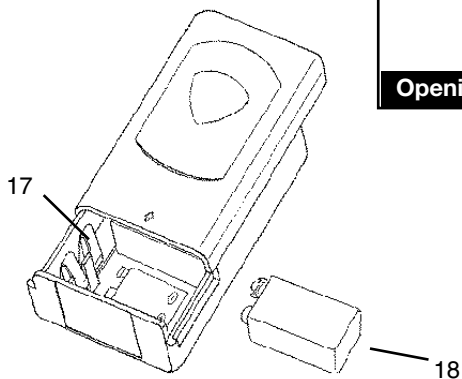
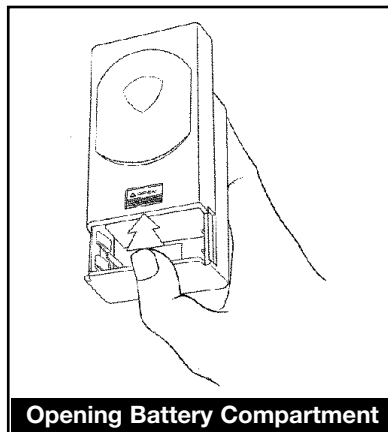

## **WGT Instrument Bodypack Transmitter**

1. Snap open the **BATTERY COMPARTMENT (25)** and insert a fresh **9V BATTERY (26)**, observing the correct polarity. Close the compartment. The WGT-15 is provided with a **3.5 mm LOCKING JACK (27)** for connecting the **INSTRUMENT CABLE (28)**. To secure the connection, turn the metal slip ring on the plug clockwise to thread it on to the jack. To unplug, reverse the process. Slip the transmitter into a pocket or clip on to your clothes or instrument strap.

*(Note: As the cord to the instrument also serves as the antenna, be sure to extend it fully for maximum range. Rolling up or shortening the cord may reduce the effective operating range.)*

2. Turn on the WGT by sliding the **OFF/STANDBY/ON SWITCH (29)** to the **STANDBY** position (transmitter on, audio muted) or the **ON** position (transmitter and audio both on). The **BATTERY INDICATOR LED (30)** will give a single quick flash, indicating usable battery strength. In the case of a dead or low battery, the LED either will not go on at all or will stay on continuously, indicating that the battery should be replaced with a fresh one.

3. The WGT transmitter is now ready to use. The **TX DISPLAY LEDs (7)** on the 401X Quad receiver should now be lit, indicating a received signal from the transmitter. Adjust the volume of the receiver as per the *Audio Output Instrument Connections* section of the above 401X Quad receiver instructions. The **AF LEVEL LED DISPLAY (7)** on the 401X Quad receiver will light up as if the input signals are getting stronger. Occasional flickering on and off during use of the LED indicator is normal. However, if the LED stays on continuously, turn down the instrument volume control or noticeable distortion may result. For ultra high-gain instrument sources such as active bass pickups or even extra hot guitar pickups, an attenuation pad may be required to eliminate unwanted distortion.

*(Note: The **INPUT LEVEL CONTROL (31)** is not operable because it is preset and switched internally at the factory to instrument GT input mode. The control is only used for Headworn Mic (HM) and Lavalier (LT) input modes.)*

*(Note: Scratchy noises can sometimes occur when some electric guitars/basses with dirty pots or connections are used with any wireless system. For this reason, the supplied **INSTRUMENT CORD (28)** has a factory installed capacitor inside the 1/4" plug. This capacitor provides first order filtering of the RF signal from the cord into the guitar and eliminates virtually all scratchy noises. Should your equipment still produce scratchy noises, we suggest these steps to eliminate them:*

- 1) Make sure all guitar volume and tone pots are clean and all contacts are solid – this is very important.*
- 2) Provide extra filtering with a 220 pF capacitor soldered across the hot to ground terminals of the guitar's volume and tone pots.)*

# OPERATION

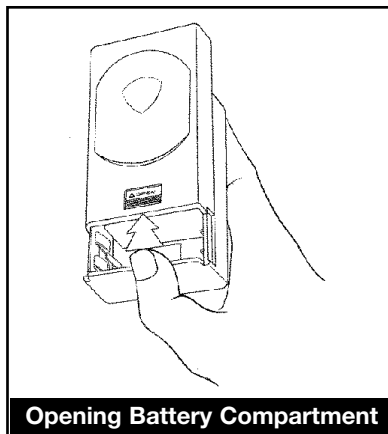

Opening Battery Compartment

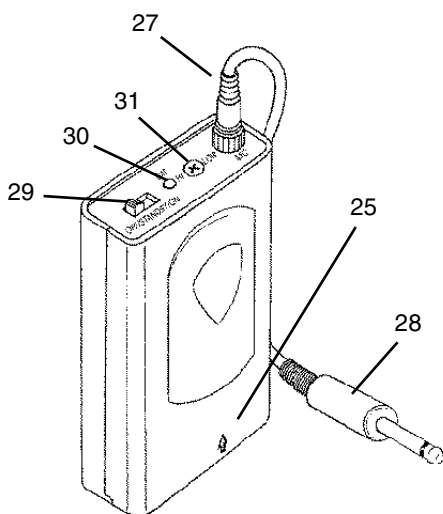
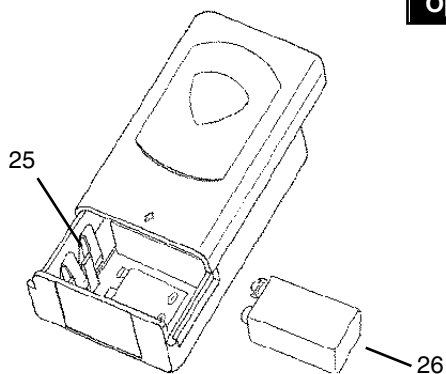

## The LINK 2™ Plug-In Transmitter

### 1. Transmitter Set-Up

First, slide open the **BATTERY COMPARTMENT DOOR (39)** to expose compartment. Insert a fresh **9V ALKALINE BATTERY (41)**, observing polarity. Close the battery compartment door.

### 2. Handheld Microphone Installation

- Step 1 - Rotate the transmitter's threaded **LOCKING RING (33)** clockwise toward the **XLR CONNECTOR (32)** until it stops.
- Step 2 - Hold your mic in one hand and The Link 2 in the other.
- Step 3 - Plug your mic into the **XLR CONNECTOR**.
- Step 4 - Lock the mic into place with the adjustable threaded **LOCKING RING** by rotating the ring, counterclockwise, to the top of the transmitter.
- Step 5 - To release the **XLR CONNECTOR**, turn the threaded **LOCKING RING** clockwise and press the **RELEASE BUTTON (40)**.

### 3. Lavalier Microphone Installation

The lavalier microphone you are using must terminate with an XLR connector and conform to the pin assignments shown below. If they do not conform, you must use an appropriate adapter or the lav mic may not work with the Link 2. If you have any questions, please contact your Nady dealer or Nady Systems' Customer Service Department.

**Note: the pin assignments on The Link 2's XLR connector are as shown:**

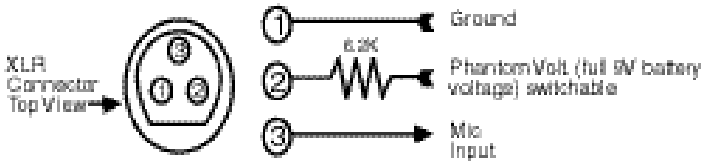

*Note: Select phantom power, as needed, with the PHANTOM POWER ON/OFF SWITCH (38)*

#### 4. Microphone Operation

a. Turn on The Link 2 by sliding the **ON/STANDBY/OFF SWITCH (37)** to the STANDBY position (transmitter on, audio muted) or the ON position (transmitter and audio both on). The **LOW BATTERY INDICATOR LED (36)** will give a single quick flash, indicating usable battery strength. In case of dead or low battery, the indicator will either not go on at all or stay on continuously, indicating a battery voltage below 7V. If this occurs, replace with a fresh 9V battery. Remember to turn the transmitter off when not in use.

b. The Link 2 is now ready to use. The **AF LEVEL LED DISPLAY (7)** on the 401X Quad receiver should now be lit, indicating a received signal from the transmitter. When ready to speak, slide the transmitter switch to the ON position and adjust the volume of the receiver as per the **Audio Output Microphone Connection** section of the above 401X Quad receiver instructions. The **AF LEVEL LED DISPLAY (7)** on the 401X Quad receiver will light up as if the input signals are getting stronger. Occasional flickering on and off during use of the LED indicator is normal. However, if the LED stays on continuously, it means the signal is too loud and there is the possibility of overload distortion. Re-position the microphone farther from the source or adjust the Link 2 transmitter gain with the **VOLUME LO/HI GAIN SWITCH (35)**. Set for the maximum possible level without noticeable distortion on the high level peaks. Set the **GAIN SWITCH** to LO to decrease the audio level, and set the **GAIN SWITCH** to HI to increase the audio level. The red LED indicator should flicker only on the loudest inputs.

*[Note: Observe care in selecting P.A. volume, transmitter location and speaker placement so that acoustic feedback (howling and screeching) will be avoided. Please also observe the pickup patterns of the microphone selected: omnidirectional mics pick up sound equally from all directions and are prone to feedback if not used carefully. Unidirectional mics are more resistant to feedback, but pick up sound sources best that are directly in front of the mic. Also, mics that are farther from the sound source, such as lavaliers, require more acoustic gain and thus are also more prone to feedback than close-source mics such as handheld or headworn mics that are used close to the mouth.]*

*(Note: Microphone elements can easily be destroyed by the buildup of salts and minerals from perspiration and saliva. It is good practice to put a windscreen on the mic element at all times to protect it.)*

---

## O P E R A T I O N

---

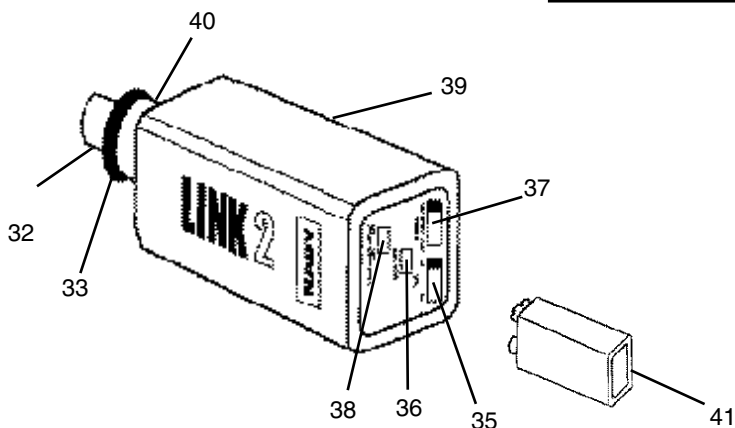
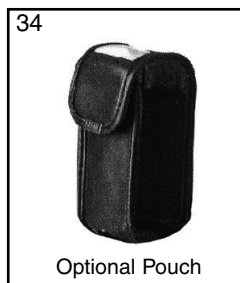

- 32 ***XLR Connector*** – Connects microphone to the transmitter module for signal input
- 33 ***Locking Ring*** – Locks microphone to the transmitter
- 34 ***Optional Pouch*** – For lavalier bodypack operation (with beltclip and strap ring for securing)
- 35 ***Gain Control Switch*** – Adjusts the input sensitivity (LO or HI)
- 36 ***Low Battery LED*** – Single flash (power on), lit steady (low battery)
- 37 ***Power Switch*** - Turns the power ON/STANDBY/OFF. In standby position, the power is on and the audio is off.
- 38 ***Phantom Power ON/OFF Switch*** – Turns the phantom power ON/OFF
- 39 ***Battery Compartment***
- 40 ***Release Button*** – Press to release XLR connector
- 41 ***9V Alkaline Battery***



---

---

# S P E C I F I C A T I O N S

---

---

## 401X Quad OVERALL SYSTEM PERFORMANCE

Frequency Response	30-18KHz (-3dB)
Dynamic Range	120dB (20-20KHz)
Total Harmonic Distortion	<0.5% (typical)
RF Carrier Frequency Range	170-230MHz (Factory installed Channels)
Frequency Stability	+/- 0.005%, crystal controlled
Modulation	FM (F3E), +/-15KHz nor,+/-30KHz max
Operating Range	250 feet typical — up to 500+ feet optimum line-of-sight

## 401X Quad TRANSMITTERS

### Audio Inputs

- WHT Nady DM-10D neodymium dynamic cartridge
- WLT/WGT 3.5mm mono locking jack for connecting to omni or unidirectional lavalier mic or unidirectional headworn mic, with phantom power (WLT); or connecting to instrument cable (WGT)
- LINK 2™ Locking XLR jack for connecting to microphone or cable, with selectable phantom power

### Controls

- WHT OFF/STANDBY/ON switch
- WLT/WGT OFF/STANDBY/ON switch, input level adjust
- LINK 2™ OFF/STANDBY/ON, LO/HI Level, and ON/OFF Phantom power switch

### LED Indicator

Unit "ON" (single flash), Low Battery Alert (steady)

### RF Power Out

50mW (Max. allowed by FCC)

### Harmonic & Spurious Emissions

<-40dB

### Battery

9V Alkaline

### Battery Life

Up to 20 hours

### Dimensions

- WHT 9.5" X 1.4" Diam. (24.1 X 3.5 cm)
- WLT/WGT 4.1" X 2.4" X 0.8" (10.4 X 6.1 X 2.0 cm)
- LINK 2™ 4.5" X 1.5" X 1.25" (11.4 X 3.8 X 3.2 cm)

### Weight (w/o battery)

- WHT 6.9 oz (193 g)
- WLT/WGT 3.6 oz (101 g)
- LINK 2™ 2.6 oz (71 g)

## 401X Quad RECEIVER

### Controls

Power ON/OFF, volume control, mute control

### Connectors

1 unbalanced adjustable mixed (all four channel)  
1/4" T-S audio output jack. Line level, 600 ohms.  
4 balanced fixed level XLR. #1=GND, #2-3=signals  
Line/Mic level, 11k/600 ohms

### Receiver

2.1 mm barrel-type DC input jack (tip=positive)

### LED Indicators

1 Power ON LED, 4 AF LED, 4 TX ON LED

### Dimensions

1.75" x 7.5" x 16.5" (4.4 x 19 x 42 cm)

### Weight

4.5 lbs (2 Kg)

### Power Requirements

16V @ 800mA, nominal, AC/DC adapter supplied

### Antenna Connectors

Dual female BNC connectors

---

---

## S E R V I C E

---

---

(U.S.) Should your Nady 401X Quad Wireless Microphone System require servicing, please contact the Nady Service Department via telephone at (510) 652-2411 or e-mail to [service@nady.com](mailto:service@nady.com) for a Return Authorization (R/A) Number and a service quote (if out of warranty). Make sure the R/A Number is clearly marked on the outside of the package when you sent it in and enclose a cashier's check or money order (if not prepaid with a credit card). Please ship the unit prepaid to: Nady Systems, Inc., Service Department, 6701 Shellmound Street, Emeryville, CA 94608. Please include a brief description of the problem you are experiencing.

**The warranty card enclosed with this system contains additional valuable warranty and service information. Keep it in a safe place for possible future reference. Do not attempt to service this unit yourself as it will void the warranty.**

**(International)** For service, please contact the Nady distributor in your country through the dealer from whom you purchased this product.

Nady wireless microphone systems are type accepted under  
FCC rules parts 90, 74, and 15.

This device complies with RSS-210 of  
Industry & Science Canada.

Operation is subject to the following two conditions: (1) this  
device may not cause harmful interference and (2) this device  
must accept any interference received, including interference  
that may cause undesired operation.



NADY SYSTEMS, INC. • 6701 SHELLMOUND STREET, EMERYVILLE, CA 94608  
Tel: 510.652.2411 • Fax: 510.652.5075 • [www.nady.com](http://www.nady.com)