

OWNER'S MANUAL



4W-1KU

1000-Channel UHF Quad Receiver
Wireless System



Contents

Introduction	2
Using this Manual.....	2
System Features	3
Quick User Controls Guide.....	4
System Operation	8
4W-1KU Receiver.....	8
HT-1KU Handheld Microphone Transmitter.....	10
BT-1KU Bodypack Transmitter.....	12
Specifications	15
Cautions and Troubleshooting	16
Miscellaneous Tips	17
Frequency.....	19
Accessories	19
Service Information	19
Warranty.....	20

Introduction

Thank you for choosing the Nady 4W-1KU QUAD wireless system, and congratulations on your choice. The Nady 4W-1KU QUAD wireless system has the best performance and price value in professional UHF wireless, offering clear-channel, frequency-agile operation on the UHF band for interference-free performance in any application or locale. The Nady 4W-1KU QUAD wireless system has four independent UHF receivers, each delivering 1000 user-selectable channels with auto-scan for easy finding of clear channels, frequency synthesized in pre-programmed 00-09 groups and 00-99 channels in the (U.S.) Band 1: 672.000-696.975MHz, (Int.) Band 2: 795.000-819.975MHz ranges. The Nady 4W-1KU QUAD wireless system features proprietary companding and low-noise circuitry for an industry-best 120dB dynamic range, and the clearest, most natural sound available in wireless today.

Using This Manual

This booklet provides instructions for the operation of the 4W-1KU and includes a description of features, a quick user controls guide, a step-by-step guide to operations for each unit, system specifications, a troubleshooting guide, miscellaneous tips, and servicing information. Please refer to the Nady 4W-1KU frequency guide for the frequency band(s) and channels utilized by your system.

System Features

4W-1KU Receiver

- Unsurpassed state-of-the-art PLL UHF performance with 120dB dynamic range and operation up to 500 feet line-of sight
- Four complete and independent wireless receivers with 1000 user-selectable UHF frequencies for simultaneous operation of four transmitters
- True Diversity circuitry with two complete front ends per receiver for maximizing range and most effective elimination of signal dropouts
- AUTO-SCAN for easily locating clear channels and ASC™ (Auto-Sync Channel) IR download feature which sends selected Group/Channel information to transmitter via IR sender for easy frequency synchronization
- Sophisticated IF filtering for simultaneous operation of multiple systems in the same location
- Front panel touch control buttons and user-friendly LCD configuration menus
- Front panel backlit LCD display indicates selected Group, Channel, RF signal strength meter; Audio Output Volume level; Diversity A/B LED indicators
- Back panel Balanced XLR Mic level and Unbalanced ¼" SUM Line level audio output jacks, squelch control, RF BNC connectors for dual removable ½ wave antennas, and DC power input jack supply
- Externally powered (adapter included)
- Rugged all-metal housing— 1U rack mountable with supplied rack ears (front antenna mount kit optional)
- Works with any four combinations of available instrument, handheld and lavalier UHF transmitters

HT-1KU Handheld and BT-1KU Bodypack Transmitters

- Choice of transmitters: HT-1KU or BT-1KU, all with 1000 easily selectable channels: manually with up/down buttons on units or via IR Sync download of selected channel for easy synchronization with receiver
- HT-1KU Handheld transmitter features a sleek, durable all-metal housing; power Off/On switch; internal antenna system; and superior neodymium cartridge for clear, powerful audio, maximum feedback rejection, and minimal handling noise
- BT-1KU bodypack transmitter (choice of three versions: LT, LT/HM, or GT) features road worthy all-metal case; power Off/ Mute/On switch; flexible external antenna rod; and mini locking connector for lapel (LT), Headmic™ (LT/HM), or instrument (GT) applications
- HT-1KU and BT-1KU transmitters feature LCD displays indicating selected Group, Channel, Audio Input Levels, and Battery level status; transmitting High/Low RF power switch for optimizing distance operation depending on application; and operation with two AA batteries (alkaline or rechargeable NiMH) for longest reliable, economical battery life

Quick User Controls Guide

4W-1KU Receiver: Front View

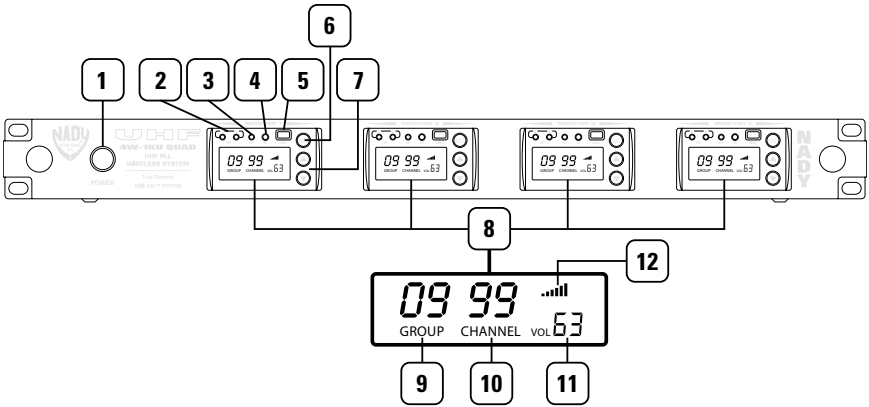

- 1. POWER BUTTON** Press for one second to turn both receivers ON-OFF
- 2. DIVERSITY A/B INDICATOR** Indicates receiver A or B is active when transmitter is on
- 3. AF PEAK LED** Shows flickering GREEN LED is normal or solid GREEN LED is for maximum audio allowable
- 4. IR** Infrared LED transmitter window for linking the RX to the TX for frequency download
- 5. AUTO-SCAN/ASC (IR SYNC) BUTTON** Long press (hold ~2 seconds) for AUTO-SCAN to locate a clear channel to use. Short press (~1 second) to make the IR link download the receiver's selected frequency to the TX. To download, positioning the HT-1KU/BT-1KU transmitters' **IR Window (34/43)** by 6-12" away from the **RX IR LED (4)**. Press the **ASC Button (5)** once and wait one second for the RX to respond. If the download is successful, the RX will show one of the **Diversity A/B Antenna LED (2)** and full **RF LCD Bars (12)** on the **LCD Display (8)**
- 6. SET** To scroll through the LCD menu and set the selected program/function
- 7. ▲ UP BUTTON** To change the receiver output VOL level, GRP/CH up by one step at a time
▼ DOWN BUTTON To change the receiver output VOL level, GRP/CH down by one step at a time
- 8. LCD DISPLAY** For indication of A-B Diversity, GRP (00-09)/CH (00-99), RF signal strength indicator 1-6 bars, and Volume Levels (0-63)
- 9. FREQUENCY GROUP** Indicates selected GROUP from 00-09
- 10. FREQUENCY CHANNEL** Indicates selected CHANNEL from 00-99
- 11. SUM VOLUME LEVEL** Indicates selected LINE output level from 00-63, (63 is loudest output)
- 12. RF SIGNAL METER** Indicates received signal strength levels from 1-6 bars, (6 bars show excellent incoming RF signal)

4W-1KU Receiver: Back View

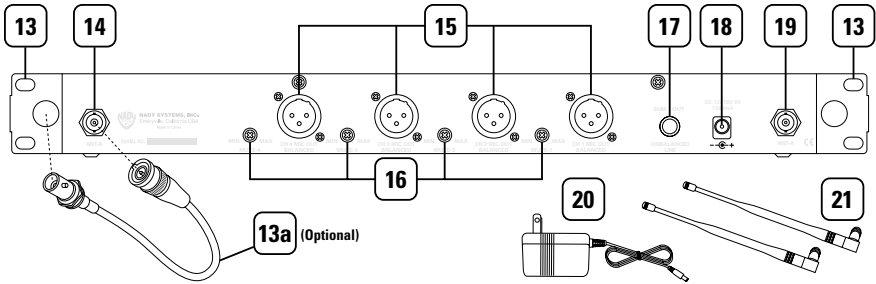

13. RACK EARS Left and Right rack ears are built into the unit

13a. ANTENNA EXTENSION CABLES (Optional)

Attach coax cables with BNC connectors from back antenna jacks to rack ear holes for front antenna mounting configuration

14. RF CONNECTORS Antenna jack A for RF True Diversity reception

15. BALANCED MIC OUT Audio output connection for each receiver—fixed Mic level

16. MUTE (SQUELCH) CONTROLS Control the mute level for each receiver—turn CW for maximum range; turn CCW for minimum range, if needed, to minimize noises from outside RF interference upon muting

17. UNBALANCED AUDIO OUT SUM Volume Level audio output for four receivers—adjustable LINE level

18. DC INPUT JACK For using external DC adapter to power the receivers

19. RF CONNECTORS Antenna jack B for RF True Diversity reception

20. DC POWER SUPPLY UNIT DC Adaptor connects to DC Input Jack (18)

21. ANTENNAS $\frac{1}{2}$ wave antennas connect to A/B Antenna Jacks (14, 19)

Quick User Controls Guide

HT-1KU Handheld Transmitter

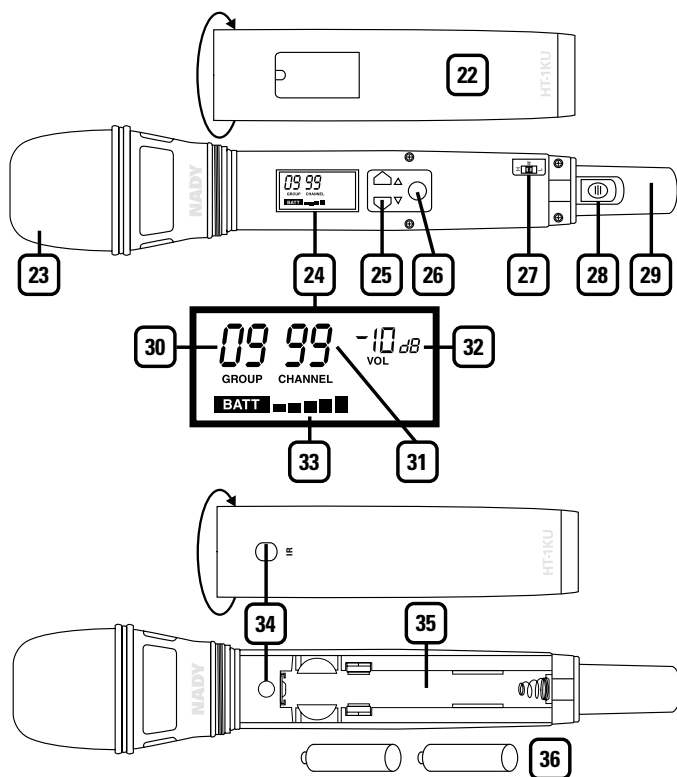

22. BATTERY COVER Unscrew CW and full down to insert two AA alkaline batteries

23. MIC BALL Windscreen/dust cover

24. LCD DISPLAY For indication of GRP (00-09)/CH (00-99), AUDIO INPUT LEVEL (0dB to -30dB), and BATTERY status (5 bars and "BATT." See 30/31/32/33 in HT-1KU transmitter diagram above for detail LCD display indicators.

25. ▲ UP BUTTON To change the GRP/CH or VOL level up by one step at a time or to light up the display

▼ DOWN BUTTON To change the GRP/CH or VOL level down by one step at a time or to light up the display

26. SET To scroll through the LCD menu and set the selected program/function

27. RF POWER SWITCH Select the TX power level high or low output

28. POWER ON/OFF SWITCH Slide power switch up-down to turn ON-OFF

29. INTERNAL ANTENNA Built-in antenna

30. FREQUENCY GROUP Indicates selected GROUP from 00-09 or to light up the display

31. FREQUENCY CHANNEL Indicates selected CHANNEL from 00-99 or to light up the display

32. INPUT VOLUME LEVEL Indicates input audio level ranging from 00dB to -30dB

33. BATTERY METER Indicates battery status (5 bars=100%, 1 bar=20%). Change batteries when flashing "BATT"

34. IR RECEPTOR SENSOR/WINDOW Infrared LED sensor for IR frequency download from RX

35. BATTERY COMPARTMENT

36. TWO AA ALKALINE BATTERIES

Quick User Controls Guide

BT-1KU Bodypack Transmitter (LT, LT/HM or GT)

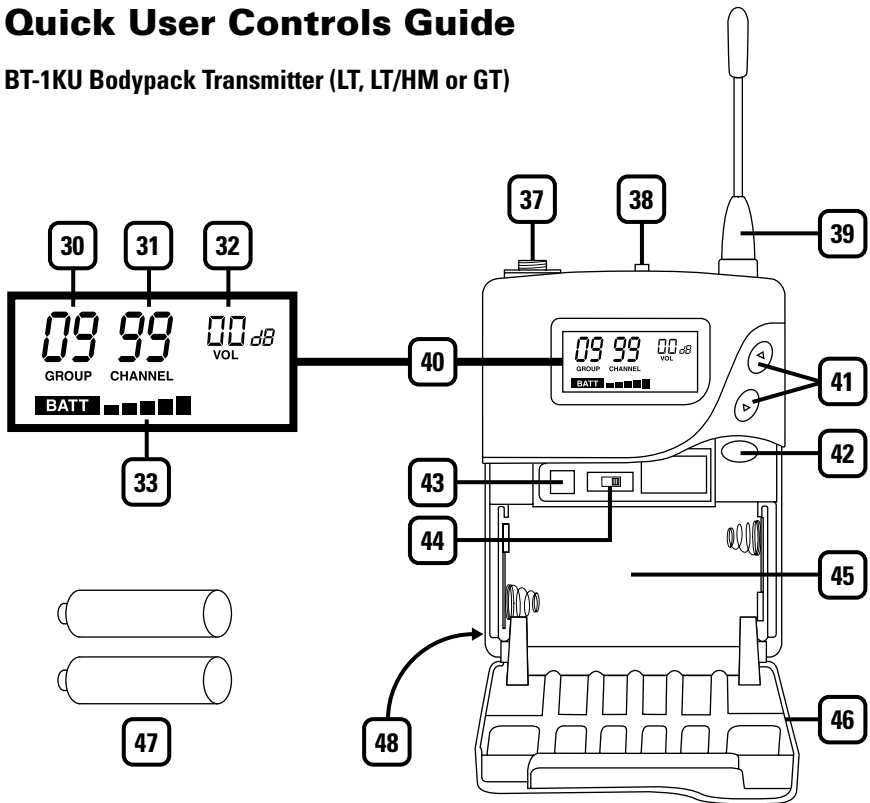

37. INPUT JACK 3.5mm locking mini jack for connecting audio input cord from lapel mic (LT), Headmic™ (LT/HM), or instrument (GT)

38. POWER OFF/MUTE/ON SWITCH Slide power switch to ON or OFF to turn ON-OFF; set to MUTE to turn power on with audio muted

39. ANTENNA Permanently attached antenna

40. LCD DISPLAY For indication of GRP (00-09)/CH (00-99), AUDIO INPUT LEVEL (0dB to -30dB), and BATTERY status (5 bars and "BATT." See 30/31/32/33 in HT-1KU transmitter diagram above for detail LCD display indicators.

41. ▲ UP BUTTON To change the GRP/CH or VOL level up by one step at a time or to light up the display

▼ **DOWN BUTTON** To change the GRP/CH or VOL level down by one step at a time or to light up the display

42. SET BUTTON To scroll LCD menu and set the selected program/function

43. IR RECEPTOR SENSOR Infrared LED sensor for linking the TX to the RX during IR frequency download

44. RF POWER HI/LOW SWITCH Select the TX power level high or low output

45. BATTERY COMPARTMENT

46. LATCHING BATTERY COMPARTMENT DOOR

47. TWO AA ALKALINE BATTERIES

48. BELT CLIP (on back of unit)—removable clip can be set for top of transmitter pointing either up or down

System Operation

4W-1KU Receiver

Buttons Function

The **Power Button (1)** is used to turn ON or OFF all four receivers at the same time. When this power button is pressed for two seconds, the blue backlights on the **LCD Displays (8)** will light up indicating the receivers are on. Press the Power button again for two seconds to turn off the receivers. The backlight on the LCD will display "OFF" indicating the receivers are off. At power-off the 4W-1KU QUAD receivers will store the last settings entered and re-display them at power-on. It can be reprogrammed to any new Group/Channel, or Volume level. The default factory setting is Group 00 (Receiver 1) and 03 (Receiver 2), 06 (Receiver 3) and 09 (Receiver 4), Channel 00 and Volume 63 are same for all receivers.

The **▲ (Up) or ▼ (Down) Buttons (7)** are active while in the Set mode, or can be used to change **Volume Level (11)** at anytime.

When the **Set Button (6)** is repeatedly pressed the **LCD Display (8)** menus will cycle in the following order:

MAIN MENU > VOLUME > GROUP > CHANNEL > MAIN MENU (repeats)

During manual programming, the selected function will flash for five seconds or press the Set button to confirm the selection and the display will return to the main menu.

The **AUTO-SCAN / ASC (IR Sync) Button (2)** has two functions:

- Long press (hold ~2 seconds) for AUTO-SCAN for finding a clear channel within the frequency band (with all TXs turned off at this time). Clockwise running segments on the LCD display show the scanning is in progress which normally takes ten seconds. When it finds an interference-free channel, it will display and store that

channel for use. Then ASC IR Sync the TX as described below.

- Short press (~ 1 second) to transfer the selected frequency information from the receiver to the transmitter for easy synchronization prior the transmitter can be used. When short pressing the ASC IR Sync button while the main menu is displayed, the **IR LED (4)** will light up red and stay for about three seconds. This indicates IR transmission is in progress and IR data is transferring during this period. A transmitter should be used at this time to receive data from the receiver (see *IR Sync Programming in Programming sections of HT-1KU and BT-1KU transmitter sections*). Upon successful data transferred (usually in about three seconds) the IR LED stops and the transmitter's backlight will light up and the transmitter will transmit a radio signal on the same channel as the receiver. The Signal Strength and Diversity Indicators on the receiver's LCD display will then light up, indicating that the IR link is completed. If manual channel selection is preferred, skip this selection.

***Note:** If you are using multiple transmitters at the same location, set up the first transmitter and leave it ON and keep it 3 ft. away from the receivers. Then start AUTO-SCAN on the second receiver. This avoids duplicate selection of the same channel as already selected for the first receiver. Using these procedures for the remaining receivers to be used.*

If you are not satisfied with a channel after scanning, repeat anytime for locating another free channel.

Selecting the 4W-1KU QUAD Receiver Volume Level / Group / Channel

This section will also aid in finding desired channel(s) of operation when setting up your system(s).

Press the **Set Button (6)** three times to check the current **Volume Levels (12)** setting.

To change the Volume Levels, press the **▲ (Up) or ▼ (Down) Buttons (7)** anytime for single stepping, or hold the Up/Down button continuously for faster level selection. Select 1 of 63 (soft to loud sound) levels from the Volume menu and advance to exit Setup Mode by pressing the Set Button one more time. Selecting 0 should mute the receiver and no output for the Line Out only. The XLR out is unaffected.

Choose the 4W-1KU QUAD operating frequency by selecting one of ten **Groups (9)** and one of 100 **Channels (10)** that are determined to be desirable open channels. Press the Set button to enter the Group setup mode and the Group icon will flash, then press the Up/Down button once for single stepping through the groups, or hold continuously for faster group selection. Select 1 of 10 groups available from the Group menu and then press the Set button again to Channel Setup Mode and the Channel icon will flash, or press the Set button three times to skip changing the Channel or Volume. Within the Channel Setup menu, press the Up/Down button once for single stepping through the channels, or hold continuously for faster channel selection. Select 1 of 100 channels available from the Channel menu or press the Set button twice to skip Volume Level setting and exit to main menu. During manual programming, the selected function will flash for five seconds or press the Set button to confirm the selection and the display will return to the main menu. For detail how to IR Sync the TX, see *IR Sync Programming* in *Programming* sections of HT-1KU and BT-1KU transmitter sections.

Rack-mounting the Receiver

The Nady 4W-1KU QUAD receiver wireless system has built-in **Rack Ears (13)**. Use the supplied screws to install the receiver onto the rack.

Note: Do not mount the receiver on a rack directly above an amplifier or other source of high heat. This could degrade the performance of the

4W-1KU QUAD. Always ensure adequate airflow and heat dissipation in any rack configuration.

Installing Antennas

Install antennas by connecting the two **Antennas (21)** included with your system onto the two **RF Connectors (14/19)** located on the back of the 4W-1KU QUAD receiver. The two antennas must be installed in order for the diversity circuit to work properly. The optimal positions of the antennas are 45° from the receiver and 90° from each other. For maximum range, it is always best to maintain a line-of-sight (no obstructions) between the receiver antennas and the transmitter at all times whenever possible.

To install optional **Antenna Extension Cables (13a)**, insert one end of each cable into a rack ear hole and secure using the removable nut. Clip the other end of the cable to an **RF Connector (14/19)** on the back of the unit. Connect the two antennas to the front of the system.

Powering the Receivers

To power the receivers, plug the provided AC/DC **Power Supply (20)** adapter into the DC **Input Jack (18)** on the back of the receivers, then plug the adapter into an AC outlet.

Note: Any 16-18VDC source with minimum 800~1000mA capacity can also be used.

Once the receiver is connected to the power source, press the **Power Button (1)** for two seconds. The **LCD Displays (8)** will light (showing Group, Channel, RF Level Meter, and Output Volume). The **Diversity A/B (2)** and the **AF PEAK LED (3)** are off at this time and will display when the transmitter is on and the audio is transmitted. To turn off, press the Power button for two seconds. The LCD will display "OFF" then the backlight will turn off indicating the receivers are off.

Connect either the ¼" **Unbalanced Audio Out (17)** or each **XLR Balanced Mic Outs (15)** to your mixing board, effect, or amplifier inputs (See *Connecting the Audio Outputs* section).

Adjusting the Squelch

In normal operation, each 4W-1KU QUAD receiver's **Mute Control (16)** works independently and should be adjusted clockwise (CW) to the minimum RF squelch setting at which the **RF Level Meter (12)** and one of the LED **Diversity A/B Indicators (2)** will remain on while your transmitter is in normal use, up to the maximum operating range anticipated in use for your application. However, in areas of high RF activity, the MUTE control may need to be adjusted counterclockwise (CCW). If the transmitter is off, the receiver signal and the **RF Signal Meter (12)** and one of the LED Diversity A/B Indicators is flickering or stay on continuously, the MUTE level should be adjusted higher level CCW (counterclockwise for less mute sensitivity level) to stop the flickering. Be careful not to adjust too high CCW setting as this may reduce the operating range to below what is needed. A range walk test will help in selecting the proper level. If the range is not critical, note that a counterclockwise (maximum mute) setting will also yield a quieter mute function, which might be desired in certain applications. The MUTE level is factory preset at clockwise (CW) for maximum sensitivity and operating range (i.e. clockwise (CW) for minimum squelch level—maximum usable range).

Audio Level and Peak LED Indicator

The 4W-1KU QUAD receiver has an **AF Peak LED (3)** display for each receiver and each works independently per channel. The AF Peak LED occasional flickering green on normal or loud inputs to the transmitter is normal. If the AF Peak LED lights green continuously, you might overload the system. Decrease the audio level input to the transmitter or overload distortion sound may result.

Connecting the Audio Outputs

The 4W-1KU QUAD receiver has one **Unbalanced Audio Out (17)** (adjustable Line level) SUM audio output and four **Balanced**

Mic Out (15) (fixed level) XLR jacks and each output works independently per receiver. The Unbalanced Audio Out is controlled by **▲ (Up) or ▼ (Down) Buttons (7)** for volume control and the receiver **Sum Volume Meter (11)** will indicate the level selected. For unbalanced output, plug an ¼" mono (Tip/Sleeve) audio cable into the **Unbalanced Audio Out (17)** and plug the other end into your mixing board or amplifier. When using the BT-1KU instrument transmitter system, connect the Unbalanced Audio Out directly to your instrument amp or preamp. At maximum receiver volume setting, as indicated by the Sum Volume Level display, the system output is approximately +4dB higher than a direct cord-to-amp connection. Note that all receivers output will be mixed together as per the individual receivers' volume settings as selected by the up/down volume controls. If separate signals are required for each instrument then the Balanced Mic Out sockets must be used. However, they are not line level or adjustable. The SUM out is best utilized for switching between separate transmitters during performance with only one audio signal at a time fed to the instrument amplifier. For balanced output, plug an audio cable with an XLR connector into each receiver and plug the other end into your mixing board or amplifier inputs accordingly.

Note: As when making any connection, make sure the amplifier or mixing board volume is at the minimum level before plugging in the receiver to avoid possible sound system damage.

Your 4W-1KU QUAD receiver is now operational and ready to use. Once you have completed the above steps, proceed to the following instructions for the HT-1KU Handheld or BT-1KU Instrument transmitter.

Note: Only one transmitter can be used with one receiver. It is not possible to use two transmitters on the same frequency and mix the output of these transmitters into one wireless receiver. However, as this is a four receiver unit, four transmitters on separate frequencies can be utilized, one with each receiver.

HT-1KU Handheld Microphone Transmitter

Buttons Function

The **RF Power Level Switch (27)** is used to select Hi/Low power transmission.

Each time the **Set Button (26)** is pressed, the LCD menu will cycle in the following order:

*MAIN MENU > VOLUME > GROUP >
CHANNEL > MAIN MENU* (repeats)

The **▲ (Up) or ▼ (Down) Buttons (25)** work in the set mode only. They can be used to change any Group/Channel as selected (if not using IR Sync from receiver).

They can also be used to select the desired Input audio level VOL setting. Or they can be used to turn on the LCD display.

During manual programming, the selected function will flash for five seconds, or press the Set button to confirm the selection and the display will return to the main menu.

Setting up the Transmitter

The HT-1KU requires two AA size batteries to operate. To install the batteries onto the battery compartment, unscrew the **Battery Compartment Cover (22)** by turning counterclockwise until loose and slide down the cover, exposing the **Battery Compartment (35)**. Insert two fresh **AA batteries (36)** according to the correct polarity as indicated on the transmitter body. Screw the battery cover back onto the microphone, making sure it is securely tightened. Fresh alkaline batteries can provide up to 8-10 hours of operation, but in order to ensure optimal performance it is recommended that the batteries be replaced after 6-8 hours of use or as indicated to be necessary by the flashing **Battery "BATT" Meter Icon (33)**.

Powering the Transmitter On/Off

To turn on the transmitter, slide the **Power On/Off Switch (28)** to the "ON" position. The LCD backlight will light up, indicating the unit is now on. After ten seconds the backlight will automatically turn off to conserve battery life. The **Group (30), Channel (31), Input Volume Level (32), and Battery Meter (33)** indicator icons stay on for normal operation.

As many of the LCD battery meter levels should stay lit as possible, as they indicate usable battery strength. As the batteries weaken, fewer of the level indicators will stay lit until only one bar shows, which will then flash to warn that the batteries are now too low and should be replaced as soon as possible with fresh ones.

To preserve battery life, turn the transmitter off when not in use. To turn the transmitter off, slide the power on/off switch to the "OFF" position. The LCD will display "OFF," no LCD or backlight is lit up and the unit will be off.

At Power Off the transmitter will store the last settings entered and re-display them at the next power on where it can be reprogrammed to any new Group/Channel or Volume level at the first time of use or anytime later. The factory default setting for Volume -10dB is same for all transmitters. These settings are optimal for most applications.

Programming the HT-1KU to the Selected Channel

The transmitter can be programmed to the same frequency as selected for the receiver, either via automatic synchronization using the IR Sync function or manually on the transmitter itself.

IR Sync Programming:

Use the wireless **IR LED Receptor Sensor (34)** to download pre-programmed channels from the receiver. Start programming by holding the IR Receptor Sensor/Window

about 6-12" from the receiver to be used. On the receiver, when short pressing the **ASC IR Sync Button (5)**, while the main menu is displayed, the **IR Infrared LED (4)** will light up red and stay for about three seconds. This indicates IR transmission is in progress and IR data is transferring during this period. Upon successful data transfer (usually in about three seconds) the IR LED stops and the transmitter's backlight will light up and the transmitter will transmit a radio signal on the same channel as the receiver. The Signal Strength and Diversity Indicators on the receiver's LCD display will then light up, indicating that the IR link is completed. Note, if procedure is not done correctly during the three seconds of active data transfer, the receiver and the transmitter do not link and transmitter's previous programmed channel remains unchanged.

***Note:** The IR link is infrared light and thus works best when this data transfer is accomplished in a light-shielded or darker environment. It may not be successful in a brightly lit area. If the transfer fails, repeat the procedure in a darker location or somehow shield the link from outside light to successfully program the transmitter with the pre-programmed group and channel info from the receiver.*

Manual Programming (GRP/CH and Volume):

The transmitter's frequency is set using the **Set Button (26)** and then the **▲ (Up) or ▼ (Down) Buttons (25)**. During manual programming, press the Set button to confirm the selection or the selected function will flash for five seconds and the display will return to the main menu. To start, press the Set button once. The backlight on the **LCD (24)** will light up and the **Group Icon (30)** will flash. Use the Up/Down button to change the group. When a group selection is finished, press the Set button again for the channel selection. The **Channel Icon (31)** will now flash. Again, use the Up/Down button to change the channel as desired. When the Group/Channel selection is done, press the Set button again to enter the **Volume Level Input (32)** setting and then press Up/Down

to change in four steps from 0dB to -30dB (for loudest input) or press the Set button a second time to exit to the main menu.

To change the volume input level only, press the Set button three times to select the volume input level setting. Use the Up/Down button to change in four steps from 0dB to -30dB (for loudest input). The level is preset at -10dB for the HT-1KU, which is best for most applications.

For normal operation, the transmitter should have the same Group/Channel as displayed on the receiver. For normal operation, the transmitter should have the same Group/Channel as displayed on the receiver. The default factory setting is Group 00 (Transmitter 1), 03 (Transmitter 2), 06 (Transmitter 3) and 09 (Transmitter 4), and Channel 00 for all transmitters.

After programming is finished, slide the battery cover back then turn the **Mic Ball (23)** counterclockwise to secure the housing. The HT-1KU is now ready for use.

***Note:** If you are using multiple transmitters at the same location, set up the first transmitter and leave it ON and keep it 3 ft. away from the receivers. Then start AUTO-SCAN on the second receiver. This avoids duplicate selection of the same channel as already selected for the first receiver.*

If you are not satisfied with a channel after scanning, repeat again anytime for another free channel.

Operating the HT-1KU Handheld Transmitter

During normal operation with the unit powered on, the transmitter power level can be changed by sliding the **RF Power Switch (27)** to "H" to increase the transmitted RF power (for longer range) or to "L" to decrease the RF power (reduced range). This is a useful feature as the "L" setting increases battery life and also optimizes the number of channels that can be used simultaneously in a given location. Use

this setting for normal use not requiring maximum operating range. A range walk test before use will determine which setting is best for your application.

Slide the On/Off switch to the “ON” position and the microphone is now ready to use. The receiver’s **RF Signal Meter (12)** and one **Diversity A or B Indicator (2)** should now be on, indicating a received signal from the transmitter. Adjust the volume of the receiver per *Connecting Audio Output*.

Note: *Avoid acoustic feedback (howling or screeching) by taking care in selecting PA volume, transmitter location and speaker placement.*

The RF Signal meter and the Diversity A or B indicator on the receiver’s LCD display should be “ON” in normal operation.

BT-1KU Bodypack Transmitter (LT, LT/HM or GT)

Buttons Function

The **RF Power Level Switch (44)** is used to select Hi/Low power transmission.

When the **Set Button (42)** is pressed, the LCD main menu will cycle in the following order:

MAIN MENU > VOLUME > GROUP > CHANNEL > MAIN MENU (repeats)

The **▲ (Up) or ▼ (Down) Buttons (41)** work in the set mode only. They can be used to change any Group/Channel as selected (if not using IR Sync from receiver). They can also be used to select the desired Input audio level VOL setting. Or they can be used to turn on the LCD display.

During manual programming, the selected function will flash for five seconds or press the Set button to confirm the selection and the display will return to the main menu.

Setting up the Transmitter

The BT-1KU bodypack requires two **AA Batteries (50)** to operate. To install the batteries into the battery compartment, lift the **Battery Compartment Door (46)** by grabbing the two spring-loaded locking tabs and pull out, exposing the **Battery Compartment (45)**. Insert two fresh AA batteries according to the correct polarity as indicated on the transmitter body. Close the battery cover, ensuring the cover is snapped shut. Fresh alkaline batteries can last provide up to 8-10 hours of operation, but in order to ensure optimum performance it is recommended that the batteries be replaced after 6-8 hours of use or as indicated necessary by the flashing **Battery Meter “BATT” Icon (33)**.

Connecting Input Audio Source

Use the **Audio Input (37)** 3.5mm locking mini jack for connecting the audio input cord from lapel mic (LT), Headmic™ (LT/HM), or instrument (GT), depending on which version transmitter is being used. Secure the connection to the cable by lining up the slot of the 3.5mm mini connector and turning the ring to securely lock in.

Powering the Transmitter On/Off

To turn on the transmitter, slide the **Power Off/Mute/On Switch (38)** to the “MUTE” (middle) position (transmitter on, audio muted). The LCD backlight will light up. The unit is now on. After ten seconds the backlight will automatically turn off. The **Group (30), Channel (31), Input Volume Level (32)** and **Battery Meter (33)** remain on in normal operation.

As many of the five LCD battery levels should stay lit as possible, indicating usable battery strength. As the batteries weaken, fewer of the level indicators stay lit until only one bar shows, which will then flash to warn that the batteries are now too low

and should be replaced as soon as possible. To preserve battery life, turn the transmitter off when not in use. To turn the transmitter off, slide the Off/Mute/On switch to "MUTE" and then "OFF". The LCD will display "OFF", no LCD or backlight is lit up and the unit will be off.

At Power Off the transmitter will store the last settings entered and re-display them at the next power on where it can be reprogrammed to any new Group/Channel or Volume level at the first time of use or anytime later. The factory default setting for Volume 0dB is same for all transmitters. These settings are optimal for most applications.

Programming the BT-1KU to the Selected Channel

The transmitter can be programmed to the same frequency as selected for the receiver, either via automatic synchronization using the IR Sync function or manually on the transmitter itself.

IR Sync Programming:

Use the wireless **IR LED Receptor Sensor (43)** to download pre-programmed channels from the receiver. Start programming by holding the IR LED Receptor about 6"-12" from the receiver's **IR LED Window (4)**, then press the **IR Sync Button (5)** on the receiver to be used. When short pressing the ASC IR Sync Button, while the main menu is displayed, the IR LED will light up red for about three seconds. This indicates IR transmission is in progress and IR data is transferring during this period. Upon successful data transfer (usually in about three seconds) the IR LED stops and the transmitter's backlight will light up and the transmitter will transmit a radio signal on the same channel as the receiver. The Signal Strength and Diversity Indicators on the receiver's LCD display will then light up, indicating that the IR link is completed.

Note: If procedure is not done correctly during the three seconds of active data transfer, the receiver and the transmitter do not link and transmitter's previous programmed channel remains unchanged.

The IR link is infrared light and thus works best when this data transfer is accomplished in a light-shielded or darker environment. It may not be successful in a brightly lit area. If the transfer fails, repeat the procedure in a darker location or somehow shield the link from outside light to success-fully program the transmitter with the pre-programmed group and channel info from the receiver.

Manual Programming (GRP/CH and Volume):

The transmitter's frequency is set using the **Set Button (42)** and then the **▲ (Up) or ▼ (Down) Buttons (41)**. During manual programming, the selected function will flash for five seconds, or press the Set button to confirm the selection and the display will return to the main menu. To start, press the Set button once. The backlight on the **LCD (40)** will light up and the **Group (30)** icon will flash. Use the Up/Down buttons to change the group. When a group selection is finished, press the Set button again for the channel selection. The **Channel Icon (31)** will now flash. Again, use the Up/Down buttons to change the channel as desired. When the group/channel selection is done, press the Set button again to enter volume level input setting and then press Up/Down button to change in four steps from 00dB to -30dB (for loudest input) or press the Set button a second time to exit to the main menu.

To change volume input level only, press the Set button three times to select the volume input level setting. Use the Up/Down to change in four steps from 0dB to -30dB (-30dB for loudest input). The level is preset at -10dB for LT/HM and 0dB for GT. These settings are optimal for most applications.

For normal operation, the transmitter should have the same Group/Channel as displayed on the receiver. The default factory setting

is Group 00 (Transmitter 1), 03 (Transmitter 2), 06 (Transmitter 3) and 09 (Transmitter 4), and Channel 00 for all transmitters. After programming is finished, close the battery compartment door, ensuring that it latches. The BT-1KU is now ready for use.

Note: If you are using multiple transmitters at the same location, set up the first transmitter and leave it ON and keep it 3 ft. away from the receivers. Then start AUTO-SCAN on the second receiver. This avoids duplicate selection of the same channel as already selected for the first receiver.

If you are not satisfied with a channel after scanning, repeat again anytime for another free channel.

Operating the BT-1KU Bodypack Transmitter

During normal operation with the unit powered on, the transmitter power level can be changed by sliding the **RF Power Switch (44)** to “H” to increase the transmitted RF power (for longer range) or to “L” to decrease the RF power (reduced range). This is a useful feature as the “L” setting increases battery life and also optimizes the number of channels that can be used simultaneously in a given location. Use this setting for normal use not requiring maximum operating range. A range walk test before use will determine which setting is best for your application.

The **Power Off/Mute/On Switch (38)** has three positions and functions both as a power on/off and as an audio mute on/off switch. After the unit is powered on, slide the power switch to the “ON” position to un-mute the audio. With Power Off/Mute/On switch in either in “MUTE” or ON” position the receiver’s **RF Signal Meter (12)** and one **Diversity A or B (3)** indicator should now be on, indicating a received signal from the transmitter. When ready to transmit audio, slide the power switch to “ON” to un-mute.

To mute, slide the power switch to “MUTE” again. Adjust the volume of the receiver per *Connecting Audio Outputs* section above.

Note: Avoid acoustic feedback (howling or screeching) by taking care in selecting PA volume, transmitter location and speaker placement.

The RF Signal meter and the Diversity A/B indicator on the receiver’s LCD display should be “On” in normal operation.

Instrument Use (BT-1KU/GT only)

Secure the connection of the GT (instrument) cable by lining up the slot of the 3.5mm mini locking **Input Jack (37)** connector and turning the ring to securely lock in. When ready to play, slide the **Power Off/Mute/On Switch (38)** to “ON” position to un-mute the audio. Adjust the volume lower on the receiver’s **Unbalanced Audio Output (17)** for one-to-one unity gain with a hardwired cord or select up to an added 4-5dB boost by leaving the receiver volume to maximum for normal use with guitars and bass guitars. Note this function is best when using two transmitters for switching during performance as these is only a single mixed output from the two receivers. If an individual output per receiver is desired, use the **XLR Mic Outputs (15)**, noting that those are only fixed Mic level outputs.

Note: The audio level should be adjusted on the instrument as when using a hard-wired cord. For most applications the transmitter’s **Input Volume Level (32)** should be set at 0dB for optimal performance. Use attenuation levels (-10dB, -20dB, -30dB) only for higher output instruments, such as bass guitars with active pickups, and then only if needed for cleaner sound.

Specifications

SYSTEM OVERALL SPECIFICATIONS

Operating Frequency Range	(U.S.) Band 1: 672.000-696.975MHz, (Int.) Band 2: 795.000-819.975MHz (1000 channels switchable) 25kHz/step
Freq. Synthesized	<0.005%
PLL System Frequency Stability	<0.005%
Frequency Response	30Hz-18kHz +/-3dB
Dynamic Range	120dB
Harmonic Distortion	<0.5%
Modulation	FM (F3E) +/-25kHz normal, +/-75kHz max
Operating Range	150-250 feet typical, 500+feet max line-of-sight

4W-1KU QUAD RECEIVER SPECIFICATIONS

Receiver System	Dual conversion Super Heterodyne with True Diversity (two complete receiver sections with optimum audio selected)
Selectivity	60dB, normal +/-75kHz offset
Image Rejection	-70dB, minimum
Sensitivity	-107dBm, normal
Spurious Rejection	65dB, normal
Mute Threshold	-65dBm to -95dBm (adjustable)
Controls	UP/DOWN selects, SET, IR Sync, Power ON/OFF buttons, MUTE Level control
LCD Display	Four backlight LCD panels indicating selected Group/Channel, Received RF levels, A/B diversity, and unbalanced receiver Out Volume levels
AF/Peak LED Display	5-segment LED tree indicating received audio levels from transmitter
Audio Output Level	Unbalanced output: LINE Level output adjustable Balanced output: MIC level output fixed
Output Impedance	Balanced and unbalanced: 600 Ω
Power Requirement	16VDC/0.8A
Antennas	Dual BNC right angle
Dimensions	19"W x 11"D x 1.75"H (48.26cm x 27.94cm x 4.44cm)
Weight	6.3 lbs (2.86 Kg)
Housing Construction	Metal

HT-1KU HANDHELD TRANSMITTER SPECIFICATIONS

RF Output Power	HI/LOW selectable HI: +14dBm (25mW typical), LOW: +4dBm (2.5mW typical)
Harmonic and Spurious Emission	-50dBc normal
Audio Input Levels	24mV for +/- 25 KHz deviation
Impedance	6.0 k Ω
Controls	Power ON/OFF, RF Power HI/LOW switches, Set/Up/Down Group/Channels/ Input Volume/ Battery Levels
LCD Display	Group/Channels/ Input Volume/ Battery Levels
Antenna Type	Integral
Battery Type	2 x AA alkaline batteries operation
Battery Life	8-10 hours typical
Dimensions	10"L x 2"D (25.4 cm x 5.1 cm)
Weight (w/o batteries)	11 oz (0.312 kg)
Housing Construction	Metal

BT-1KU BODYPACK TRANSMITTER SPECIFICATIONS

RF Output Power	Hi/Lo selectable HI: +14dBm (25mW typical), LOW: +4dBm (2.5mW typical)
Harmonic and Spurious Emission	-50dBc normal
Audio Input Levels	(Lapel/Lavalier—LT)/ (Headmic™ LT/HM)/ (Instrument—GT)
Input Impedance	5k Ω (Lav Mic), 500 k Ω (Instr.)
Controls	Power OFF/MUTE/ON, RF Power HI/LOW switches, Set/Up/Down
Input Connector	Mini 3.5mm with locking nut
LCD Display	Group/ Channels/ Input Volume/ Battery Levels
Antenna Type	External fixed
Battery Type	2 x AA alkaline batteries operation
Battery Life	8-10 Hours typical
Dimensions	2.5"W x 3.25"H x 1-13/16"D (6.35cm x 8.3cm x 1.82cm)
Weight (w/o batteries)	3.8 oz (0.108 kg)
Housing Construction	Metal

Specifications subject to change at any time without prior notice for purposes of product improvement

Cautions and Troubleshooting

Feedback

Avoid acoustic feedback (howling or screeching) by taking care in selecting PA volume, transmitter location and speaker placement.

Please also note the pickup pattern characteristics of the microphone selected. Unidirectional mics are more resistant to feedback. However, they pick up sound sources best that are directly in front of the mic. Also mics that are farther from the sound source require more acoustic gain and thus are also more prone to feed back than close-source mics such as handheld.

No or Low Audio

If you are not getting audio through the system, carefully re-check all setups. Especially note that the receiver and transmitter must be set to operate on the same RF channel. For BT-1KU bodypack transmitter, also confirm that the **Power Off/Mute/On Switch (38)** is not in the Mute position. The receiver's **Unbalanced Line Level Out (17)** is adjustable so make sure the **Volume (11)** is set properly.

RF Interference and Finding Open Channels

If you encounter slight receiving interference when the transmitter is far from the receiver (from other than an operating TV station on the same frequency), often it can be overcome by adjusting the receiver's **Squelch Control (16)** (see *Adjusting the Squelch*). If receiving interference on a selected channel with the transmitter off, you must reprogram the receiver and transmitter to a different channel.

See: *Selecting the 4W-1KU QUAD Receiver Volume Level / Group / Channel Programming the HT-1KU/BT-1KU to the Selected Channel*

To reprogram, you must first find an open channel. To do this, follow the operating procedure outlined in *Selecting the 4W-1KU Receiver Volume Level / Group / Channel*. With the associated transmitter off, scroll through the groups/channels to find one that shows no received signal on the receiver's **RF Signal Meter (12)** (no bars). Also, there must be no bars either on each of the three immediately adjacent channels both above and below the selected channel for optimum interference-free operation (i.e. in a field of seven adjacent channel total—with the channel used in the middle). If operating multiple 4W-1KU Series systems simultaneously, repeat this procedure with every new channel being selected, with previously tuned systems all on, both transmitters and receivers.

Please note that wireless frequencies are shared with other radio services. According to FCC regulations, wireless microphone operations are unprotected from interference from other licensed operations in the band. If any interference is received by any Government or non-government operation, the wireless microphone must cease operation or change frequencies. The above statement is valid only for use in the U.S.A.

Note: *More bars in the **Received Signal (12)** icon indicate good signal strength in operation with the transmitter on, but more than 1 bar showing with the transmitter off also indicates the presence of likely RF interfering signals at that location. If this happens, select a different GRP/CH. One bar or less is ideal for interference-free operation.*

Miscellaneous Tips

- For optimal operation with external antennas, low loss RF shielded cable should be used and the length of the cable should not exceed 10 ft. (3 m).
- The receiver antennas should be kept away from any metal surfaces whenever possible as they can reflect away or shield the incoming RF signal.
- If the receiver's volume control is set too high, it may overdrive the input of the attached audio mixer, causing distortion. Conversely, if the output is set too low, the overall signal-to-noise ratio of the system may be reduced, causing noticeable hiss. If such noise occurs, adjust the output level of the receiver so that highest sound pressure level going into the microphone transmitter causes no input overload in the mixer, but permits the mixer level control to operate in the normal range (not too high and not too low). This provides the optimum signal-to-noise for the entire system.
- Before inserting the batteries, ensure that they are inserted with the correct polarity.
- Before operation, confirm that the receiver and associated transmitter are tuned to the same frequency group and channel number.
- After making a receiver channel change, ensure that the corresponding change is also made on the matching transmitter.
- Use only brand new alkaline batteries. Do not use "general purpose" carbon batteries. When batteries are weak, replace all the batteries at the same time. Do not mix new and old batteries.
- Position the receiver so that it has the least possible obstructions between it and the transmitter. Line-of-sight is best!
- During operation, the transmitter and the receiver should be as close as possible for optimum results but never closer than 3 ft. (1 m) as that may overload the receiver's input circuitry and cause noises.
- For the best operation, the receiver should be placed at least 3 ft. (1 m) above the ground and 3 ft. (1 m) away from a wall or metal surface. The transmitter should also be at least 3 ft. (1 m) from the receiver. Keep antennas away from noise sources such as motors, automobiles, neon lights, signal processors, computers, as well as large metal objects.
- A receiver cannot receive signals from two or more transmitters simultaneously.
- Turn the transmitter off when it is not in use. For longest life, remove the batteries if the unit is not to be used for a long period as the transmitters draw a tiny residual current to maintain the programmed settings, even when turned off. Also, since batteries installed for a long time can sometimes corrode and/or leak, causing damage, it is generally recommended that batteries be removed whenever the transmitters are not being used.
- When using the BT-1KU bodypack for instrument use: Scratchy noises can sometimes occur when an electric guitar with dirty pots or connections is used with a wireless system. Therefore, the supplied capacitor provides first-order filtering of the RF signal from the cord into the guitar and eliminates virtually all scratchy noises. Should your equipment still produce scratchy noise, we suggest these steps to eliminate problems:
 - 1) Make sure all guitar volume and tone pots are clean and all contacts are solid. **This is very important.**
 - 2) Solder a 47pF capacitor across the pot to ground terminal of the guitar's volume and tone pots to provide extra filtering.

Frequency

Frequency Plan

Band 1 (U.S.): 672.000-696.975MHz

Band 2 (International): 795.000-819.975MHz

25KHz per step (1000 Channels) U.S.

Accessories

Part Number

Description

IC-U1K

Instrument cable included for BT-1KU/GT transmitter,
3.5mm locking mini plug to ¼"

Service Information

In the U.S. If you are experiencing operational problems with your system, please refer to the Support page at www.nady.com for assistance. Should your wireless system require service, please contact the Nady Service Department at (510) 652-2411 for a Return Authorization (R/A) Number and service quote (if out of warranty). Make sure the R/A Number is clearly marked on the outside of the package that you are returning.

If your unit is out of warranty, please enclose a cashier's check or money order (or pay by credit card) per instructions by the Nady Service Department. Ship your unit prepaid to: Nady Systems, Service Department, 6701 Shellmound Street, Emeryville, CA 94608. Include a brief description of the problem you are experiencing. For service of a unit under warranty, please follow the instructions in the following section.

Outside the U.S For service or warranty matters please contact the Nady distributor in your country through the dealer/store from which you purchased this product.

Do not attempt to service this unit yourself as it can be dangerous and will also void the warranty.

One Year Limited Warranty

Nady Systems, Inc. warrants to the original consumer purchaser that the unit is free from any defects in material or workmanship for a period of one year from the date of original retail purchase. If any such defect is discovered within the warranty period, Nady Systems, Inc. will repair or replace the unit free of charge, subject to verification of the defect or malfunction upon return to Nady Systems. Please do not return your Nady product to the store where it was purchased as Nady Systems handles your warranty service directly. Communication with our Service Department is the most efficient means of servicing your unit and we are dedicated to keeping you a satisfied customer.

To the extent permitted by law, any applicable implied warranties, including warranties of merchantability and fitness are hereby limited to one year from the date of purchase. Consequential or incidental damages resulting from a breach of any applicable express or implied warranties are hereby excluded. This warranty is in lieu of all other agreements and warranties, general or special, express or implied and no representative or person including a Nady dealer, agent, or employee is authorized to assume for us any other liability in connection with the sale or use of this Nady Systems' product.

Whereas some states do not allow limitations on how long implied warranties last, and do not allow exclusion of incidental or consequential damages, the above limitations and exclusions may not apply to you. This warranty gives you specific legal rights and you may also have other rights which may vary from state to state.

This warranty is subject to the following conditions:

- 1) This system must have been purchased from an authorized Nady dealer and all warranty service must be performed by Nady's service department. Any service not performed by Nady will automatically void this warranty.
- 2) Items not covered: physical damage resulting from improper handling of the unit in transit from the factory by the shipper (Nady Systems is not responsible for such damage and all such claims must be made against the shipping company by the consignee); defects caused by normal wear of the product (expendable parts are typically connectors, cables, potentiometers, switches and similar components); damage or defects caused by abuse, neglect, accident, failure to connect or operate the unit in any way that does not comply with applicable technical or safety regulations, or improper repair, excessive heat or humidity, alteration or unreasonable use of the unit, causing cracks, broken cases/housings or parts; damage caused by leaking batteries; finish or appearance items; items damaged in shipment en route to Nady Systems, Inc. for repair. The warranty is null and void if any Nady serial number has been removed or defaced.

How To Obtain Service:

- 1) If factory service is required, you must contact our Service Department at (510) 652-2411 for a return authorization (RA) number. Make sure the RA number is clearly marked on the outside of your package. (Please note: if an RA number is not included, our shipping department cannot accept your package.)
- 2) Send the unit back to Nady Systems, 6701 Shellmound Street, Emeryville, CA, 94608 freight pre-paid. You must include proof of date and place of purchase (i.e., photocopy of your bill of sale) and a brief description of the unit's problem(s) or Nady cannot be responsible for repair or replacement. Nady Systems, Inc. will not repair, nor be held responsible, for any units returned without proper identification, return address, and RA number clearly marked on the package.
- 3) Per the above, Nady will perform all warranty service and return the unit to you at no charge. Nady Systems will inform the buyer if product sent in does not meet the terms of this warranty and will provide a quote for fixing the unit and/or shipping it back exclusively at the buyer's expense.

