

max **TX™ SERIES**  
**Model TX-PCR1**  
**Paging Controlled Relay**  
**Model TX-PSD1**  
**Paging Sound Detector**

- Switching Functions Controlled by Speaker-Level Source
- Input Accepts Amplified Constant Voltage Signals
- Switch-Selectable Input: 25 V, 70 V, 100 V
- 25 Volt Input Also Accepts 8 Ω Inputs up to 75 Watts
- Transformer-Isolated Input
- Front-Panel Trimmer Provides Sensitivity Adjustment
- Signal Threshold LED Facilitates Sensitivity Adjustment
- Front-Panel Trimmer Provides Release Delay Adjustment
- LED Indicates when Module is Triggered
- Release Delay Adjustable from 3 to 25 Seconds
- Open-Collector Output Active when Module is Triggered
- Switches on Paging or Any Other Amplified Audio Signal
- 8 Amp DPDT Relay Contacts for Switching Speaker Loads (TX-PCR1)
- Ideal for Muting or Switching Primary Speakers During Paging (TX-PCR1)

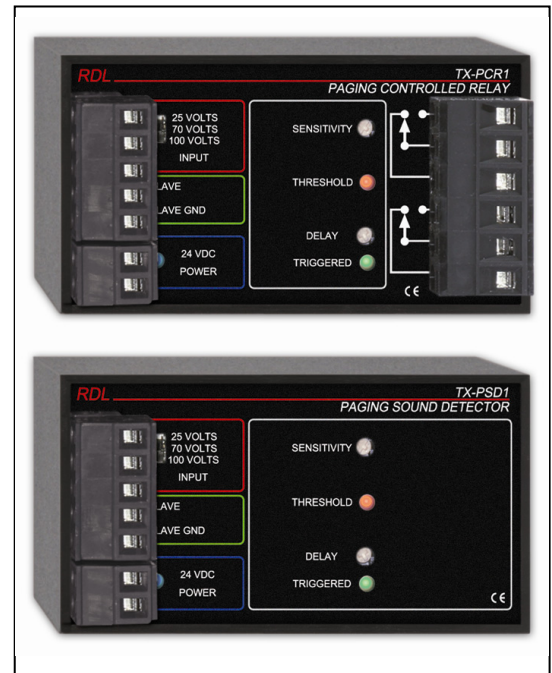

The TX-PCR1 and TX-PSD1 are audio detector and switching modules in the convenient line of Max-TX products. Max-TX modules are the large format members of the RDL TX family, featuring the superior engineering and components common to RDL products. The durable adhesives provided with these modules permit permanent or removable mounting. They may be rack or surface mounted with optional TX series accessories.

**APPLICATION:** The TX-PCR1 or TX-PSD1 is the ideal choice in many applications where switching needs to be controlled from a constant-voltage amplified audio source. These modules will trigger on any program material, with paging sources being the most common. The TX-PSD1 provides an open-collector **SLAVE** output to control other modules or equipment when a paging signal is detected. The TX-PCR1 includes both an open-collector output and a DPDT high power switching relay suited to switching speaker loads.

The amplifier audio source is connected using a detachable terminal block. A front-panel switch is provided to select the source type: 25 V, 70 V or 100 V. The 25 V setting may be used for an 8 ohm, 75 Watt maximum, amplified source. Input sensitivity is adjusted on a single-turn trimmer. In the clockwise position, the **SENSITIVITY** trigger threshold is 30 dB below the switch-selected constant voltage. A red LED illuminates whenever the audio level exceeds the trigger threshold, facilitating the sensitivity adjustment.

The module is triggered when the audio exceeds the threshold and it remains triggered for a defined time duration after the audio falls below the threshold. This **DELAY** is adjustable from 3 to 25 seconds using a front-panel trimmer. Adjustment is simplified by a green LED that remains illuminated while the module is triggered. The **SLAVE** terminal may be used as either an input or output control terminal. When the module is triggered, the **SLAVE** terminal is internally pulled to ground through an open collector. If the TX-PCR1 **SLAVE** terminal is externally pulled to ground through a switch or the open-collector terminal of another RDL module, the relay will energize until the terminal is released.

A blue **POWER** LED illuminates when the TX-PCR1/PSD1 is powered from an external 24 Vdc power supply.

Use the TX-PSD1 to control RDL modules or other equipment with ground activated control inputs that permit a 24 V pull-up. Use the TX-PCR1 relay contacts to switch speaker lines or to control the logic inputs of other equipment with control inputs that may not be pulled up to 24 V. The TX-PCR1 is ideal to provide local speaker muting during an area page. The double pole contacts allow local speakers to be automatically connected to a paging line during a page and reconnected to the local amplifier when the page is completed. If additional speaker lines need to be switched, the **SLAVE** terminal may be used to control additional TX-PCR1 modules or RDL ST-LCR1H High Power Logic Controlled Relays.

Wherever speaker-level audio needs to be detected to provide switching functions, the TX-PCR1 and TX-PSD1 are the ideal choices. Use them individually or in combination with other RDL products as part of a complete audio/video system.



**RDL**<sup>®</sup>  
Radio Design Labs

SPECIALISTS IN PRACTICAL PRECISION ENGINEERING™

TX™ SERIES

Models TX-PCR1 and TX-PSD1  
Paging Controlled Relay and Paging Sound Detector

Installation/Operation

EN55103-1 E1-E5; EN55103-2 E1-E4  
Typical Performance reflects product at publication time exclusive of EMC data, if any, supplied with product. Specifications are subject to change without notice.

Connection and Adjustment

1. Connect input speaker line from 25 V (or 8 Ohm source, 75 W max.), 70 V or 100 V source
2. Set input selector to match the source type: 25 V (or 8 Ohm), 70 V or 100 V
3. Connect external modules or OEM equipment to SLAVE output terminal; AND/OR
4. Connect speakers to relay contacts (TX-PCR1 only)
5. Initiate program audio to detect (typically a paging signal) at the lowest expected level
6. From the CCW position, adjust the SENSITIVITY control CW until the THRESHOLD LED comes on
7. Remove the input audio and adjust the DELAY control so the module remains triggered (as indicated on the TRIGGERED LED) the desired length of time (CCW=3 sec.; CW=25 sec.)

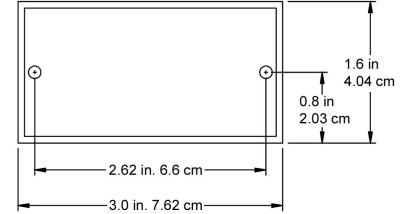

MUTE LOCAL AMPLIFIED AUDIO DURING PAGING

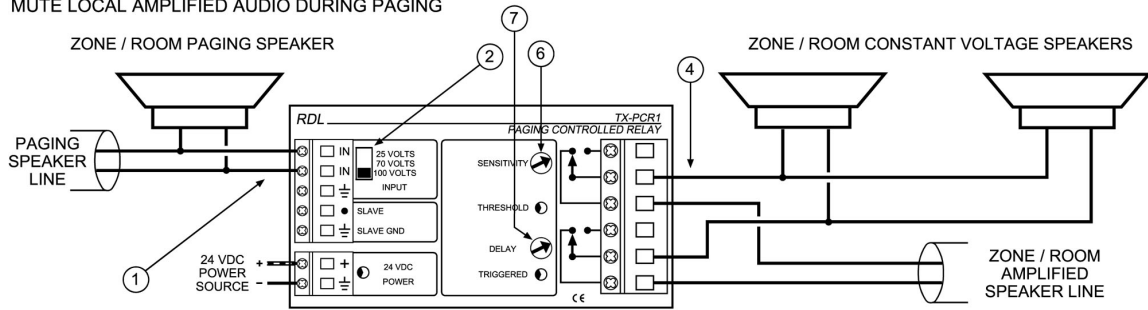

PAGING SIGNAL MUTES ZONE / ROOM AMPLIFIED PROGRAM SOURCE WHEN PAGE IS PRESENT  
NOTE: THE PAGING SOURCE AND LOCAL AMPLIFIER MUST BE SET TO THE SAME CONSTANT VOLTAGE (25 V, 70 V OR 100 V)

OVERRIDE LOCAL AMPLIFIED AUDIO WITH PAGING SIGNAL

IMPORTANT: THE MAIN PAGING AMPLIFIER MUST PROVIDE SUFFICIENT POWER TO DRIVE ALL SPEAKERS DURING PAGING.

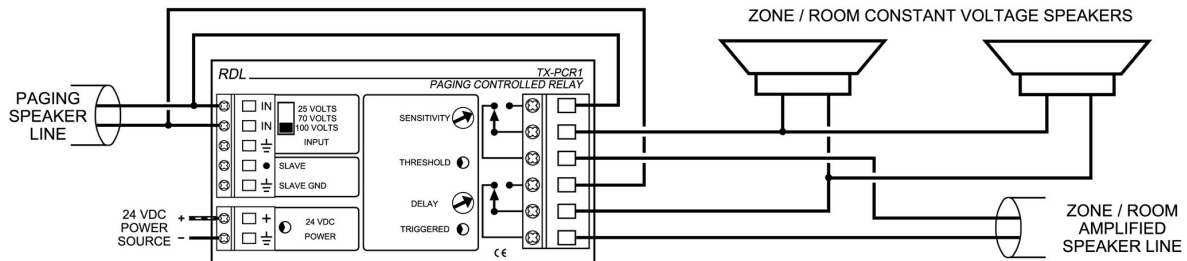

PAGING SIGNAL OVERRIDES ZONE/ROOM AMPLIFIED PROGRAM SOURCE WHEN PAGE IS PRESENT  
NOTE: THE PAGING SOURCE AND LOCAL AMPLIFIER MUST BE SET TO THE SAME CONSTANT VOLTAGE (25 V, 70 V OR 100 V)

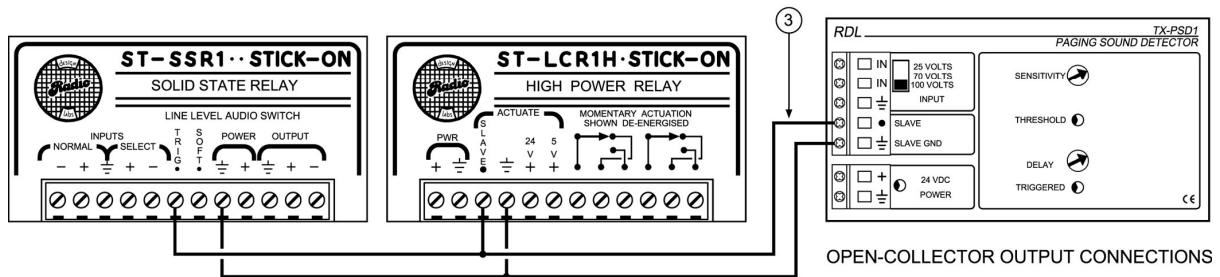

TYPICAL PERFORMANCE

Audio Input: Constant-voltage speaker line, transformer-coupled  
 Input Level: Switch-selectable 25 V, 70 V, 100 V  
 Detection Bandwidth: 120 Hz to 7.5 kHz (-3 dB)  
 Trigger Threshold: -40 dB to -15 dB (below 25 V, 70 V or 100 V), adjustable (single turn)  
 Release Delay: 3 seconds to 25 seconds, adjustable (single turn)  
 Control Output: Open collector @ 25 mA (SLAVE terminal)  
 Indicators (3): Power (blue LED), Threshold (red LED), Triggered (green LED)  
 Switching Contacts: 8 Amps maximum @ 250 Vac or 30 Vdc (TX-PCR1 only)  
 Switching Power: 500 W (amplified audio signal; TX-PCR1 only)  
 Power Requirement: TX-PCR1: 24 to 33 Vdc @ 60 mA\*, Ground referenced \*plus load current connected to SLAVE terminal  
 TX-PSD1: 24 to 33 Vdc @ 20 mA\*, Ground referenced \*plus load current connected to SLAVE output

Radio Design Labs Technical Support Centers

U.S.A. (800) 933-1780, (928) 778-3554; Fax: (928) 778-3506

Europe [NH Amsterdam] (+31) 20-6238 983; Fax: (+31) 20-6225-287