

e 906 Instrument microphone for guitar amplifiers, percussion and brass instruments

FEATURES

- Lively, full sound
- Very fast attack
- Flat shape is ideal for miking amp faces
- Three-position switchable presence filter for adaption of the sound characteristics: bright, moderate, dark
- Extra-resistant reinforced metal body

The supercardioid **e 906** instrument microphone was especially designed for guitar amplifiers, but it is also an excellent choice for percussion and brass instruments.



ARCHITECT'S SPECIFICATIONS

The instrument microphone shall be a dynamic super-cardioid designed for use with guitar amps, percussion and brass instruments. The microphone shall have a rugged metal body and shall provide a three-position switchable presence filter that allows the adaption of the sound characteristics. The frequency response shall be 40 Hz–18,000 Hz and the sensitivity (free field, no load) shall be 2.2 mV/Pa at 1 kHz. Nominal impedance shall be 350 Ω, with a min. terminating impedance of 1 kΩ.

The microphone shall provide a 3-pin XLR connector. Dimensions shall be 55 x 34 x 134 mm (2.17" x 1.34" x 5.28"). Weight shall be 140 grams (4.94 oz). The microphone shall be the Sennheiser e 906.

TECHNICAL DATA

Transducer principle	dynamic
Pick-up pattern.....	super-cardioid
Frequency response	40.....18,000 Hz
Sensitivity (free field, no load at 1 kHz)	2.2 mV/Pa
Nominal impedance.....	350 Ohm
Min. terminating impedance	1000 Ohm
Connector.....	XLR-3
Dimensions	55 x 34 x 134 mm
Weight.....	140 g

DELIVERY INCLUDES

- 1 e 906
- 1 MZH 100 clamp
- 1 pouch
- Instructions for use

e 906 Instrument microphone for guitar amplifiers, percussion and brass instruments

DIMENSIONS

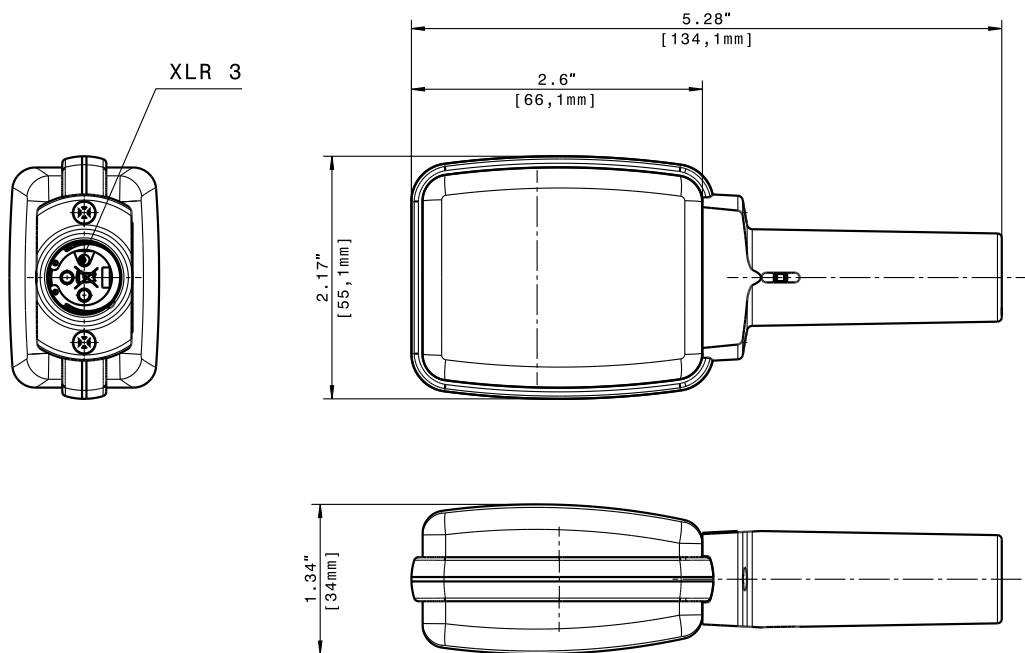

FREQUENCY RESPONSE

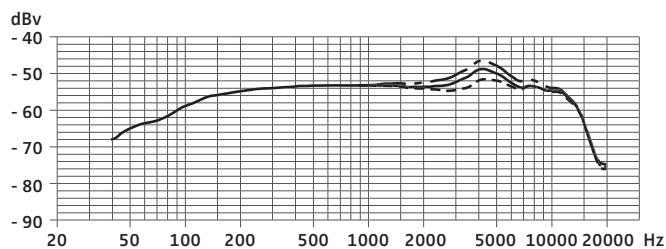

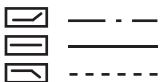
Schalterstellung  (0°, 1 m)

POLAR PATTERN

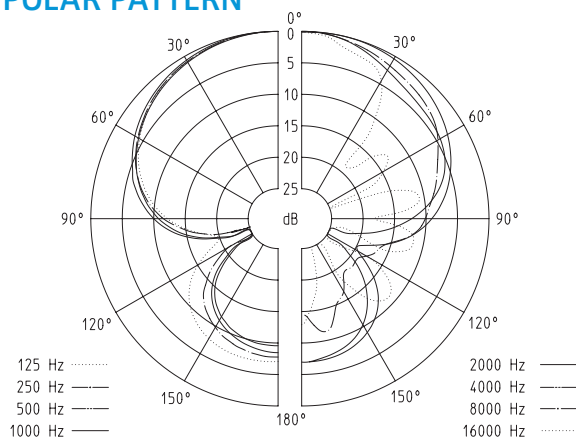

Sennheiser electronic GmbH & Co. KG
 Am Labor 1, 30900 Wedemark, Germany
www.sennheiser.com

