

HDI 830

Infrared receiver

FEATURES

- Infrared wideband receiver
- Ideal for stereo or mono applications
- Excellent signal transmission due to carrier frequencies 2.3 / 2.8 MHz
- Balance control left/right
- Ergonomic volume control
- Automatic on/off by when receiver is put on/removed
- Moveable ear pads and low weight for great wearing comfort
- Lithium polymer battery for up to 12 hours of permanent operation

The **HDI 830** is a professional 2 channel receiver. It works on carrier frequencies of 2.3 and 2.8 MHz for a high quality signal transmission. It can be used for mono and stereo applications. Intuitive operating controls make it easy to use. The included BA 300 lithium polymer battery offers up to 12 hours of battery life.



ARCHITECT'S SPECIFICATIONS

A wideband infrared stetho receiver works on carrier frequencies of 2.3 and 2.8 MHz. It provides two operating modes, mono or stereo. Balance control attenuates the volume level either on the left or the right side. The volume control is easy to access and to control. A frequency range of 50 to 16,000 Hz is covered by the receiver with a maximum sound pressure level of 125 dB at 1 kHz. The included rechargeable battery provides an operating time of up to 12 hours. The weight including the battery may not exceed 68 g. The battery shall be Sennheiser BA 300, the receiver shall be Sennheiser HDI 830.

TECHNICAL DATA

Modulation:FM, stereo
Receiving frequencies:2.3/2.8 MHz
Frequency response:50 – 16,000 Hz
Max. sound pressure level (at 1kHz):125 dB
Total harmonic distortion (at 1kHz): < 1 %
Signal-to-noise ratio:typ. 75 dB(A)
Operating time:up to 12 h
Charging time:approx. 3 h
Weight incl. battery:.....approx. 68 g

DELIVERY INCLUDES

- 1 HDI 830 stethoset receiver
- 1 BA 300 rechargeable battery
- 2 alternative pairs of ear pads
- 1 manual
- 1 quick start guide

HDI 830 Infrared receiver

DIMENSIONS

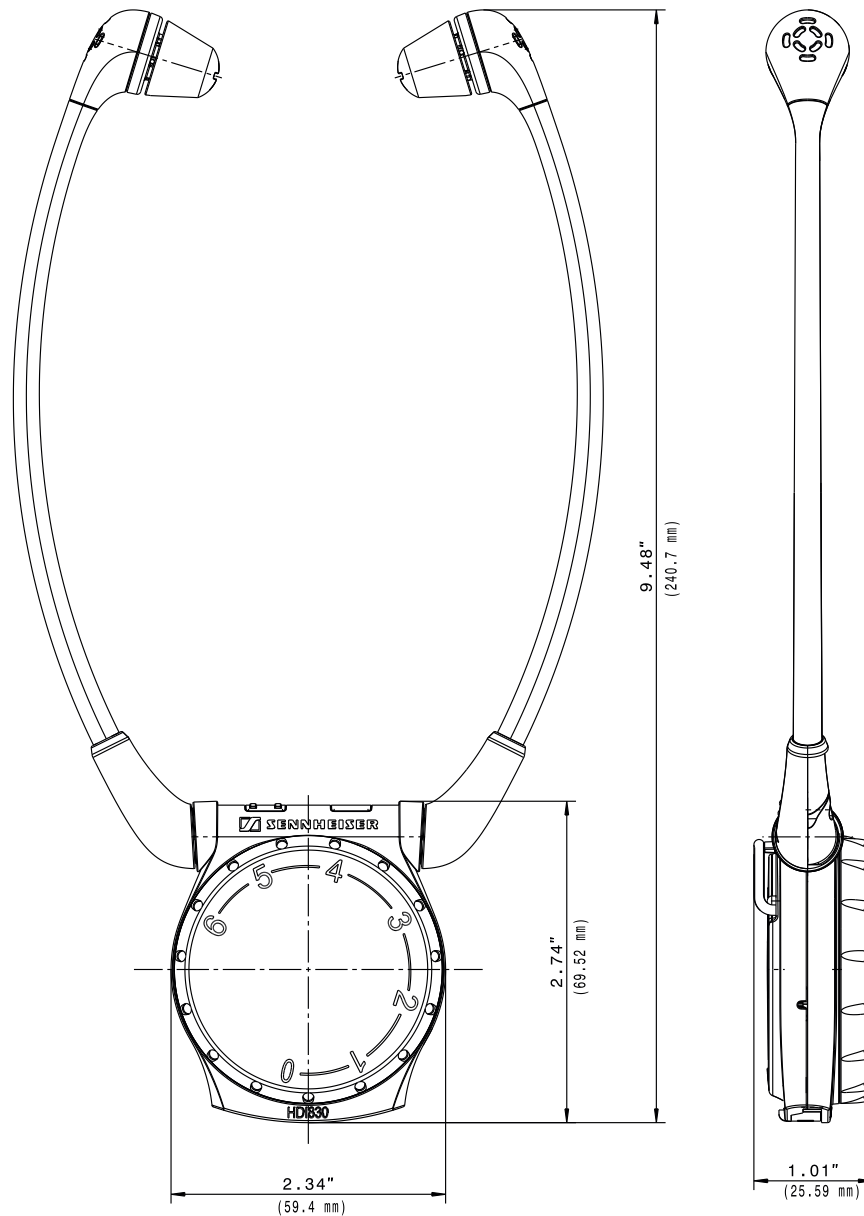

PRODUCT VARIANTS

502019 HDI 830
502021 RI 830 S

RECOMMENDED ACCESSORIES

BA 300 spare battery	Cat.No. 500898
Ear pads (silicone, black), 5 pairs	Cat.No. 528123
Ear pads (silicone, transparent), 5 pairs	Cat.No. 528124
Ear pads (foam, black), 5 pairs	Cat.No. 528125
L 300 10-10 charger	Cat.No. 502710

Sennheiser electronic GmbH & Co. KG
Am Labor 1, 30900 Wedemark, Germany
www.sennheiser.com

 **SENNHEISER**