

Product Specifications

SM48 Cardioid Dynamic Microphone

Overview

The SM48 is a rugged cardioid dynamic microphone with great sound and durable construction for reliable use in spoken word and karaoke vocal performance applications. Available with or without an on/off switch, and comes with a swivel adapter and carrying pouch for many of the benefits of the SM58 at an affordable price.

Features

- Cardioid pickup pattern rejects off-axis sound and provides superior gain before feedback
- Frequency response tailored for vocals, with brightened midrange and bass rolloff to control proximity effect
- Shock-mounted cartridge for exceptional ruggedness and reduced handling noise
- Built-in "pop" filter that reduces explosive breath sounds and wind noise
- Supplied stand adapter and carrying/storage bag
- Lockable On/Off switch (SM48S only)
- Legendary Shure quality and ruggedness

Available Models

SM48	Includes Stand Adapter and Zippered Pouch
SM48S	With Lockable On/Off Switch. Includes Swivel Adapter and a Zippered Pouch

Specifications

Type	Dynamic
Frequency Response	55 to 14,000 Hz
Polar Pattern	Cardioid
Impedance	Microphone rating impedance is 150 Ω (270 Ω actual) for connection to microphone inputs rated at 19 to 300 Ω
Output Level (at 1,000 Hz)	Open Circuit Voltage: *-57.5 dBV/Pa (1.3 mV) *1 Pa = 94 dB SPL
Polarity	Positive pressure on diaphragm produces positive voltage on pin 2 with respect to pin 3.
Connector	Three-pin professional audio (XLR), male
Net Weight	370 grams (13.1 oz)
Packaged Weight	672 grams (1 lb, 8.5 oz)
Dimensions	166 mm (6-17/32 in.) L x 54.2 mm (2-9/64 in.) W



SM48

Optional Accessories and Replacement Parts

A25D	Microphone Clip	A55M, A55HM	Isolation Mount	C25F	7.6 m Cable (25 ft)
A58WS	Windscreens	A26M	Dual Mount	RK81S	On/Off Switch
R136	Cartridge	RK248G	Screen and Grille Assembly	RK40P	Plug Assembly
S37A, S39A	Desk Stand				

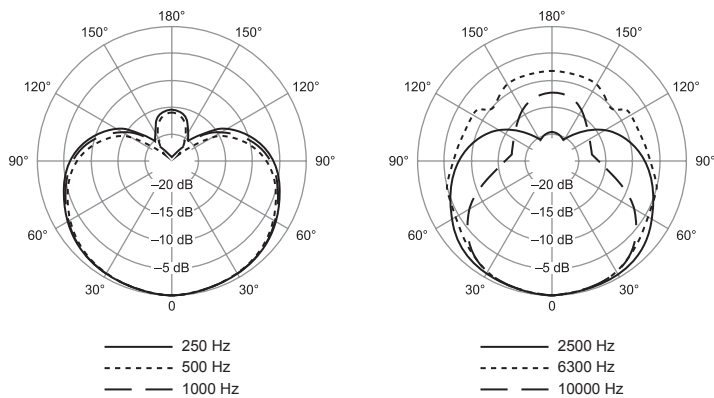

Polar Pattern
Measured at 1000 Hz

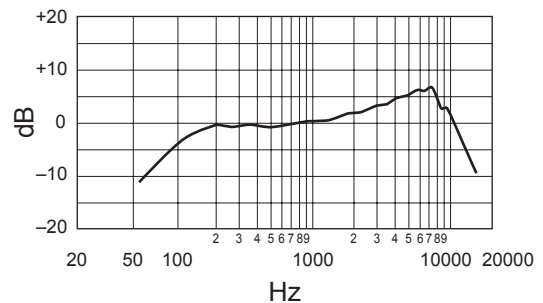

Frequency Response

SHURE[®]
LEGENDARY
PERFORMANCE™