

DESCRIPTION

The MB-15B bracket is used to mount a one-unit size component that is 420 mm in width in a component rack.

SPECIFICATIONS

Finish	Black
Weight	0.1 kg (0.22 lb.)
Accessories	Binding head Taptite screw (B tight) 3×14.....8 Binding head Taptite screw (B tight) 3×8.....6 Binding head screw M3×12.....6 Binding head Taptite screw (S tight) 5×12.....4 Fiber washer 5.2×10.5×1.0.....4

APPEARANCE

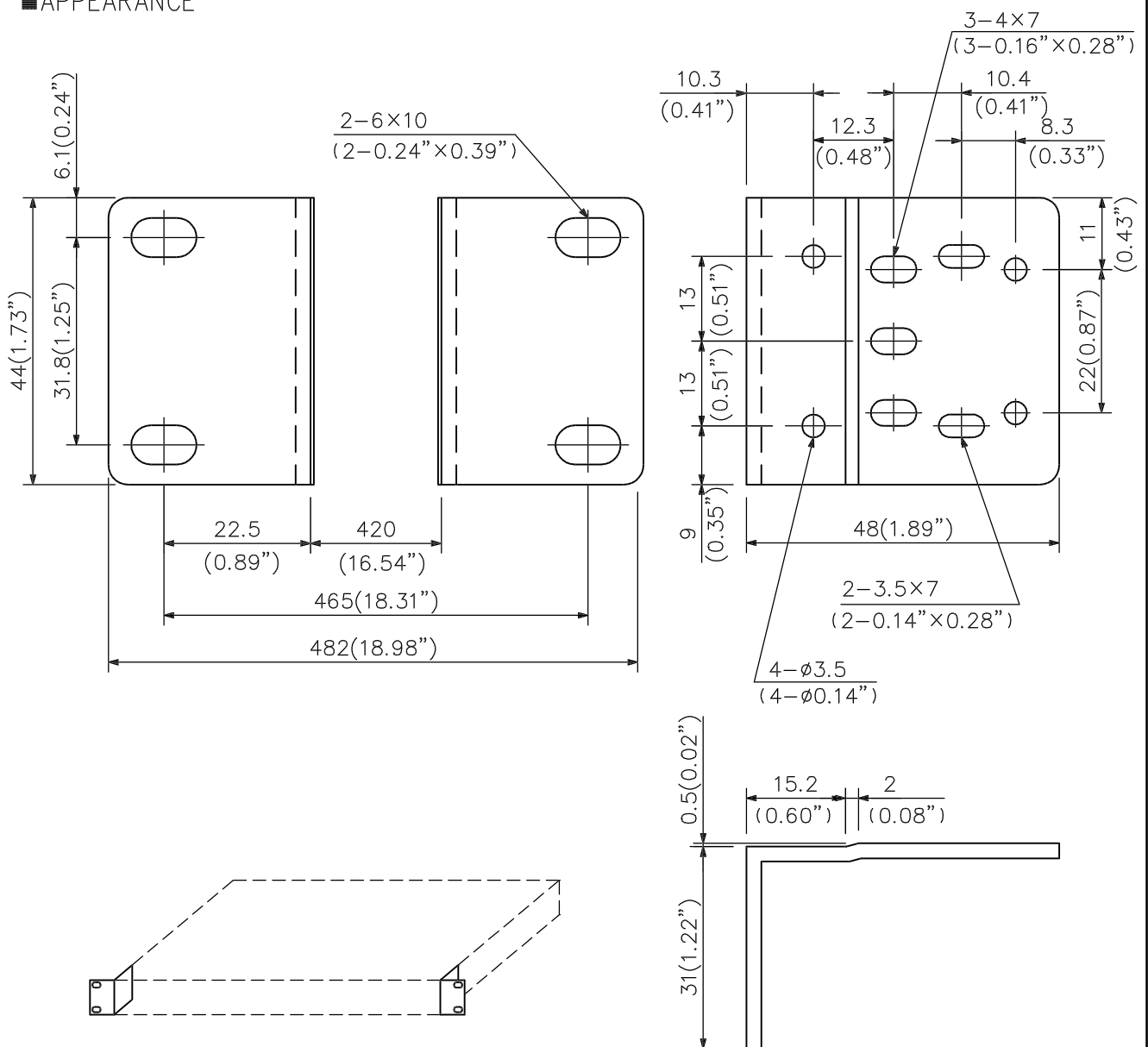

How to use mount brackets

UNIT:mm SCALE:1/1