

### DESCRIPTION

The SR-FB3 is designed to be used to suspend the Line Array Speaker.  
Only 1 speaker can be suspended using the SR-FB3.

### SPECIFICATIONS

Applicable Speaker	SR-H3S, SR-H3L, SR-H2S, SR-H2L
Finish	Steel plate, white, paint
Weight	630 g (1.39 lb)
Product Composition	Suspension bracket *1, Pull-back bracket *1, Spacer plate *1
Accessory	Suspension bracket mounting bolt (hex bolt M5 × 40 (with washer)) *2, Pull-back bracket mounting bolt (hex bolt M5 × 25 (with washer)) *2

### APPEARANCE

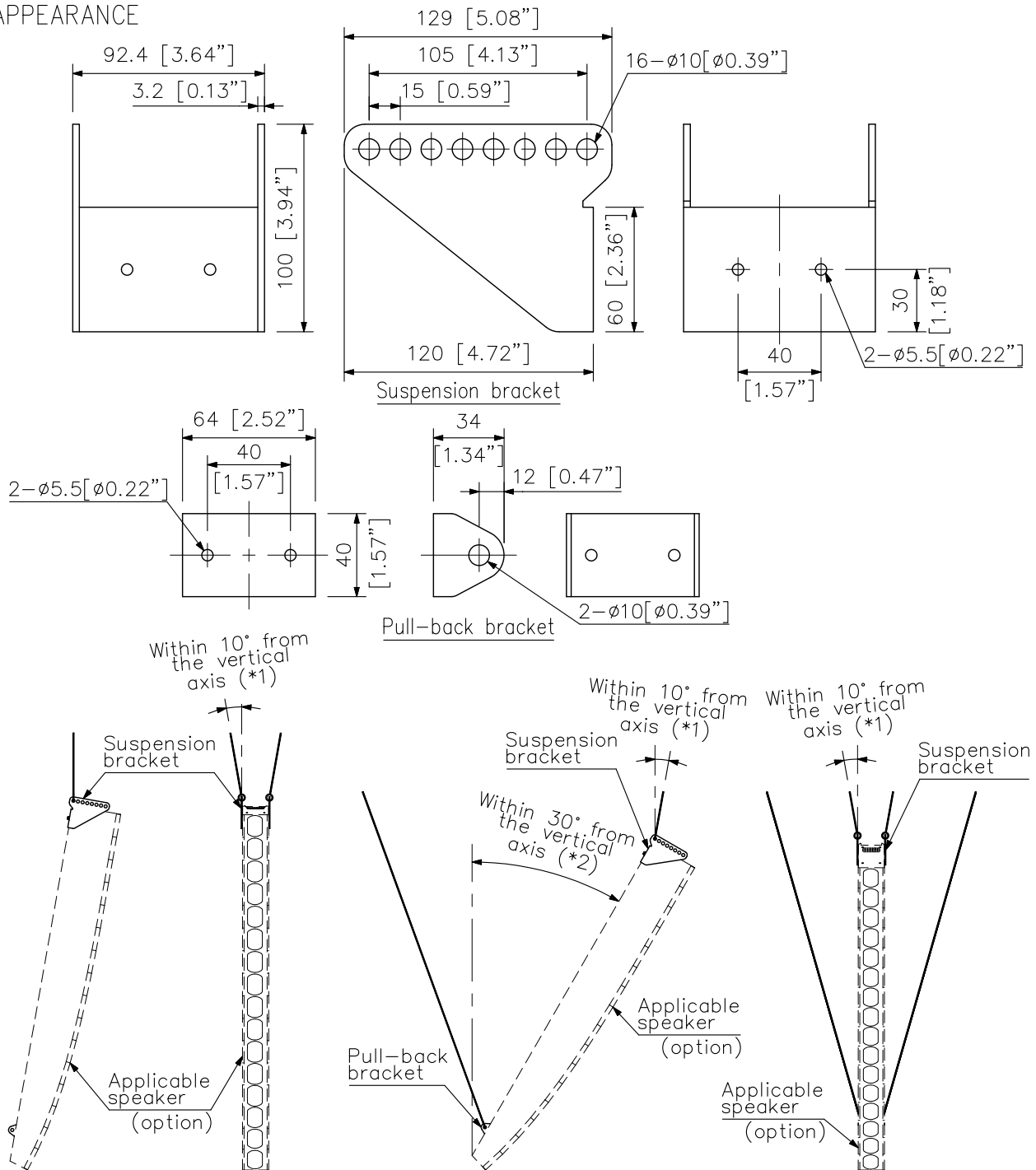

Two-wire suspension method

Four-wire suspension method

(\*1) When suspending the speaker, the angle of the suspension wires must be within  $10^\circ$  from the vertical axis.

(\*2) The inclination angle of the speaker's rear surface must be within  $30^\circ$  from the vertical axis.

UNIT:mm SCALE:1/3 Mounting example (scale: 1/20)