

Telex

Operating Instructions

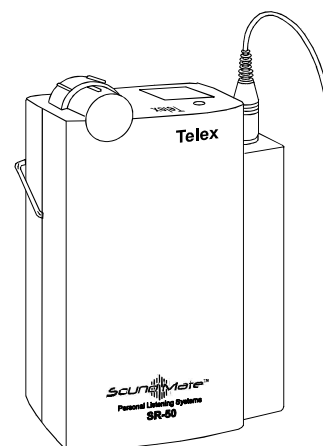
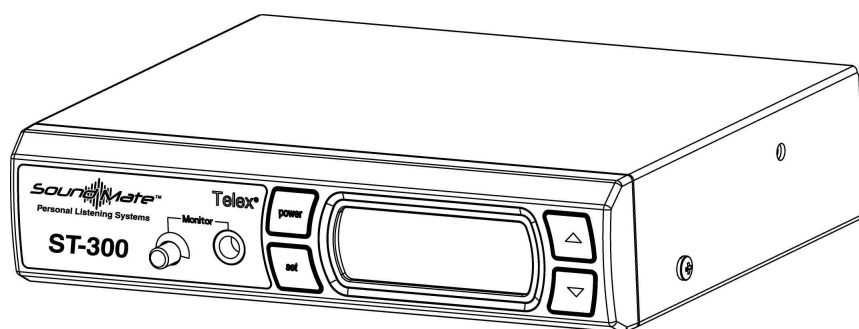

ST300

Transmitter

SR-400

17 Channel Receiver

SR-50

Single Channel Receiver

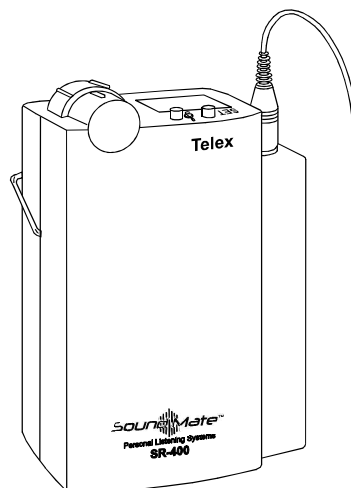

TELEX®

INTRODUCTION

WHAT IS THE TELEX SOUND ENHANCEMENT SYSTEM?

Transmitter: The transmitter generates and amplifies a RF (Radio Frequency) carrier signal, modulates this carrier with the microphone signal, and radiates the modulated RF carrier.

Receiver: The FM VHF receiver is tuned to the frequency of the transmitter. The receiver picks up the radiated RF signal from the transmitter through the antenna and converts the RF signal into audio voltages for use with an earphone, headphone, button receiver, neckloop, etc. The receiver frequency must be matched to the transmitter frequency.

WHAT FREQUENCY BAND DOES THE TELEX SYSTEM OPERATE IN?

The Telex Systems feature a synthesized transmitter and single channel or synthesized receivers operating in the VHF Band between 72-76 MHz. See Table 1 for standard frequencies available.

Each transmitter channel can be utilized by any number of receivers in any given area. Up to eight simultaneous systems can be used, and with proper placement of adjacent channels, up to ten systems can be used.

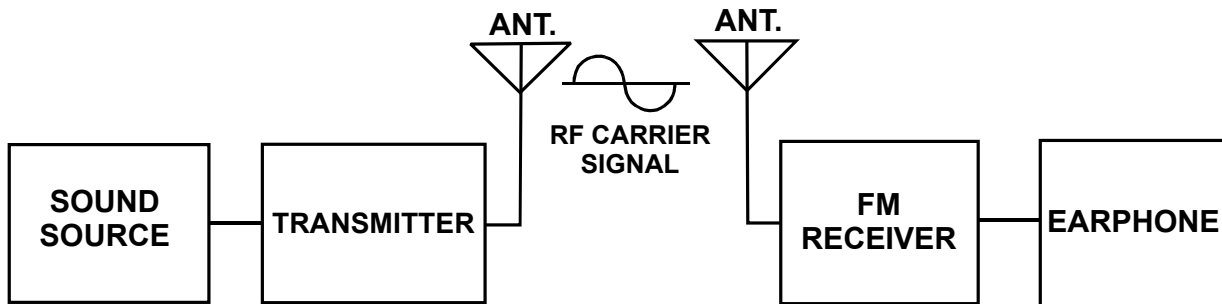

Figure 1
Block Diagram of Typical Sound Enhancement System

OFTEN ASKED QUESTIONS

Question: Can more than one system be used simultaneously?

Answer: Yes but never on the same frequency. You will need to have different frequencies for every receiver/transmitter combination. All transmitters are factory set for specific frequencies.

Question: Is the system more sensitive in any one particular direction?

Answer: No, the transmitter's antenna radiates equally in all directions, but the signal is attenuated by your body, walls or other surrounding objects. The receiving antenna is essentially sensitive in all directions as well.

Question: Can the receiver receive other transmissions when the transmitter is turned off?

Answer: Yes it can. Telex systems operate in the VHF Band between 72-76 MHz. However, it is not susceptible to radio wave skip, CB'ers or standard FM radio transmissions.

The frequency your system operates on is computer selected for least interference, but there is no such thing as a 100% clear channel all the time, anywhere in the U.S.A., forever!

If the system is going to be used in a permanent fixed location, it should operate interference free until such a time or date when someone else begins using the same frequency.

If the system is going to be moving among various locations, you may run into occasional frequency conflicts.

Whenever the system is in use, the transmitter should be left on to prevent the receiver from picking up outside interference.

AVAILABLE FREQUENCIES

CHANNEL	FREQ. in MHz
A	72.100
B	72.200
C	72.300
D	72.400
E	72.500
F	72.600
G	72.700
H	72.800
I	72.900
J	75.500
K	75.600
L	75.700
M	75.800
N	75.900
O	74.700
P	75.300
Q	75.400

Table 1
Frequencies Available

TECHNICAL INFORMATION

SR-50 RECEIVER

GENERAL DESCRIPTION SR-50

The Telex SR-50 Receiver is a component of a system which operates on 17 factory preset channels in the 72 to 76 MHz frequency band. The receivers are designed to be used with Telex ST-300 and PST-170 transmitters, but they can be used with other brands of transmitters in the 72 to 76 MHz band provided the frequencies match.

OPERATING FEATURES

Volume OFF/ON Control: The thumbwheel control serves as both an off/on switch and as a volume control.

The receiver is turned off when the control is in the extreme counterclockwise position, when viewed from the rear and the volume is loudest when the control is in the extreme clockwise position.

Headphone Jack: The receiver jack accepts a 0.140-inch (3.5 mm) diameter miniature phone plug. A variety of accessory units can be plugged into the jack for reception of the desired channels being transmitted.

Belt Clip: The belt clip supplied is detachable by spreading the wire apart at the tops and removing one side of the clip from the case and then the other.

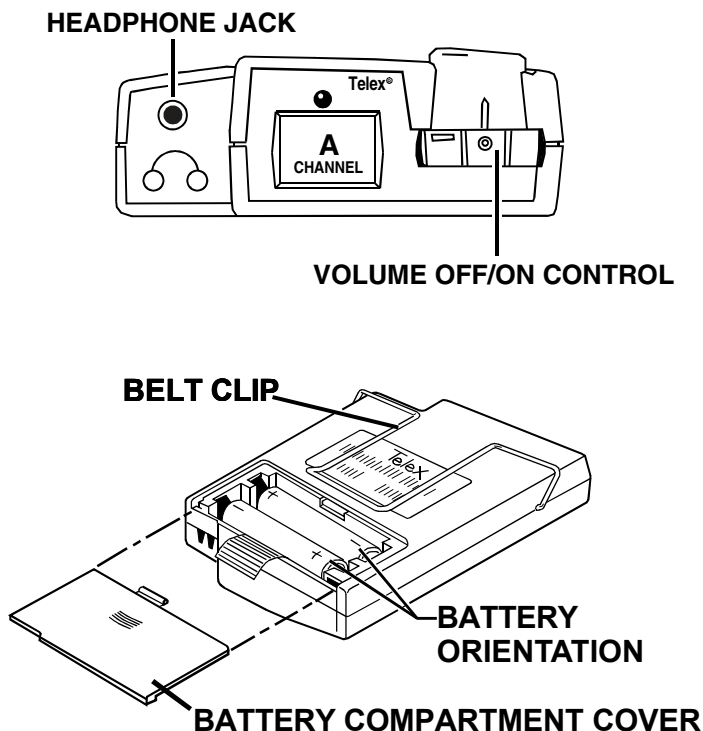

Figure 2
Operating Features SR-50

SPECIFICATIONS

SR-50 Single Channel Receiver

Temperature Range0 to +50 degrees C
Supply Voltage2-3 Volts, (2) AA Batteries
Battery Life20-30 Hrs - Alkaline
8-10 Hrs - Nicad
Sensitivity (12 dB SINAD @ 25 kHz deviation)0.5 μ V typical/1 μ V maximum
Distortionless than 2%
Frequency Response - 100 Hz-10 kHzLess than 3 dB Variation
Audio Output @ 10% Distortion

Battery Input Voltage	2.0V	3.0V
8 ohm	15 mW	80 mW
32 ohm	10 mW	50 mW

Controls and ConnectionsVolume OFF/ON Switch,
Audio Output Jack

SR-400 SYNTHESIZED RECEIVER

General Description SR-400

The Telex SR-400 Receiver is a component of a system which operates on seventeen user selectable channels in the 72 to 76 MHz frequency band. The receivers are designed to be used with the Telex ST-300 and PST-170 Transmitters.

Operating Features

Volume OFF/ON Control: This thumbwheel control serves as both an off/on switch and as a volume control. The receiver is turned off when the control is in the extreme counter-clockwise position, when viewed from the rear, and the volume is loudest when the control is in the extreme clockwise position.

NOTE: A headphone or other device must be plugged in the headphone jack in order to turn on the SR-400. This is to prevent draining the batteries if the switch is accidentally left on.

Treble Control: A push button treble control is provided to enhance higher frequency audio when the button is engaged, indicated by .

Headphone Jack: The receiver jack accepts a 0.140-inch (3.5 mm) diameter miniature plug. A variety of accessory units can be plugged into this jack for listening.

Belt Clip: The belt clip supplied is detachable by spreading the wire apart at the tops and removing one side of the clip from the case and then the other.

ST-300 SYNTHESIZED TRANSMITTER

General Description

The Telex ST-300 is a base station transmitter which operates in the 72-76 MHz band and accepts a wide range of audio input levels.

Operating Features

ST-300 Front Panel

1. Power Button
2. Headphone volume adjustment
3. Headphone Monitoring Jack
4. SET Button
5. Back Lit LCD Display
6. UP and DOWN Adjustment Buttons

ST-300 Rear Panel

1. XLR Input Connector: Accepts balanced dynamic microphone, 600 ohm line or 70 Volt line inputs
2. Unbalanced Audio 1/4" Input Connector.
3. Antenna Jack: Accepts telescoping antenna (supplied) and optional HGA-1
4. Power Input Jack: Accepts any source of 12-15 VAC/DC 700 mA minimum.

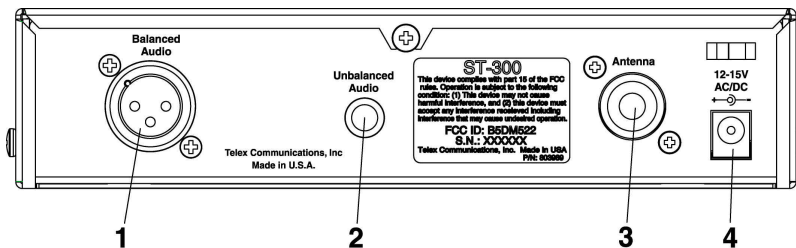
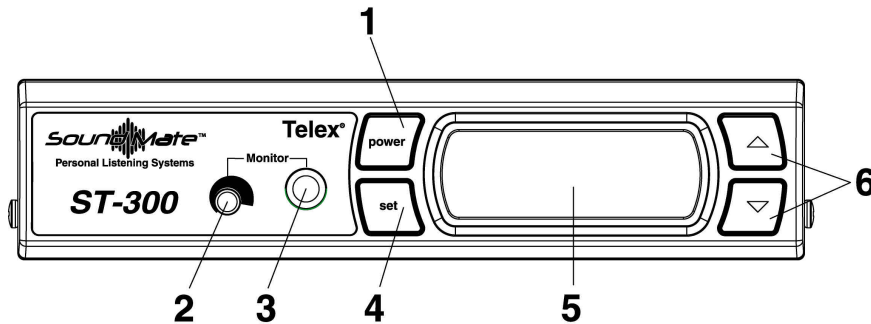
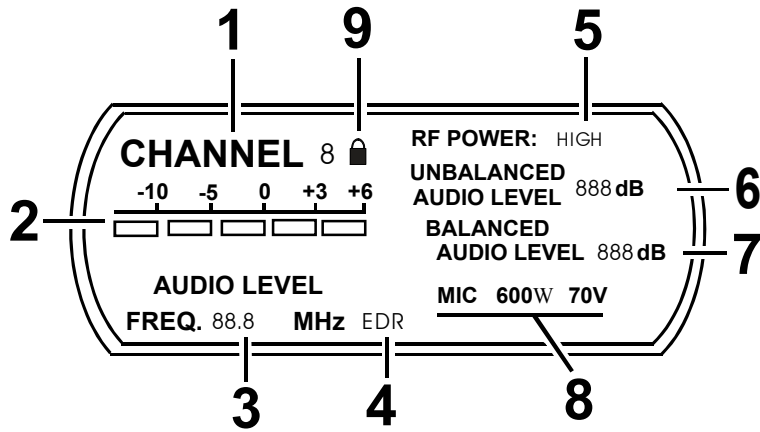

Figure 4
Operating Features ST-300
Front and Rear Panel



1. Channel Indicator
2. Audio Input Meter
3. Frequency Indicator
4. Enhanced Dynamic Range Model Indicator
5. RF Transmit Power (High when lit, Norm when not)
6. Unbalanced Audio Level
7. Balanced Audio Level
8. Balanced Input Selection
9. Lock Out Indicator

**Figure 5
LCD Display Functions**

ST-300 Specifications

Audio Input:	Balanced Female XLR
Mic Selected.....	2K ohm input impedance/0.5 mV-70 mV input range
600Ω Selected	300K ohm input impedance/70 mV-7 Volt input range
70 Volt Line Selected.....	150K ohm input impedance 7 V-70 V input range
Unbalanced Audio Input	10K Ω input impedance/10 mV-1.0 VRMS input range
RF Power Switch	80,000 μV/m at 3m in “Hi”, approx. 25,000 μV/m at 3m in “Low”
AGC Range	30 dB
Signal-to-noise Ratio:	
Normal	58 dB
EDR Enabled	77 dB
Pre-Emphasis.....	115μS
Maximum Deviation.....	+25 kHz
Frequency Control Crystal.....	+/- .005% tolerance
Available Frequencies	See Table 1, page 2
Max. Transmitter Output Power	80 mV/m at 3m
Power Requirements	12-15V, AC or DC @ 300 mA
Dimensions.....	7 ½"W x 1 ¾"H x 6 7/8"D
FCC ID.....	B5DM508

EQUIPMENT SET-UP

ST-300 Synthesized Transmitter

UNPACKING: Unpack your sound enhancement system. If there are any damages or shortages, refer to the "Warranty Service Information."

ST-300 TRANSMITTER LOCATION: Select a suitable location for the ST-300 Transmitter. Try to keep a clear, unobstructed path between the transmitter and receiver and allow plenty of free space around the transmitter antenna.

ANTENNA CONNECTIONS: Connect the telescoping antenna to the rear panel ANTENNA jack.

For best results, the antenna should be vertically aligned. Tighten the knurled ring to hold the antenna in place, and **extend the antenna to full length.**

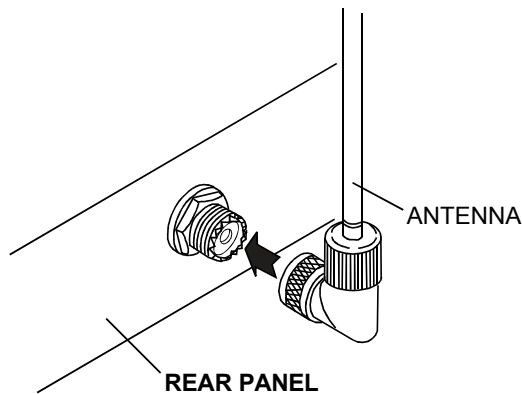

Figure 6
Antenna Connection

POWER CONNECTION: Plug the AC power adapter into an electrical outlet. Plug the other end of the cord into the power input jack on the rear panel of the ST-300.

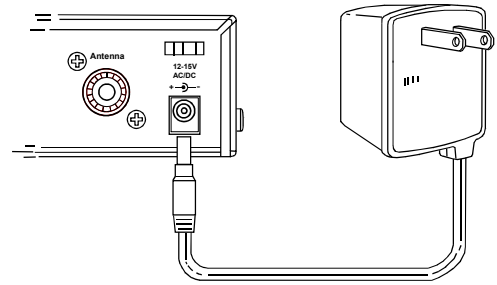

Figure 7
Connecting Power

SYSTEM SET UP SESSION

All of the channel and input selection functions are accessed from the front panel. Press SET button once to begin a Setup Session. Whenever a function is flashing, the UP and DOWN buttons can be used to adjust it. Once set, the next function will start to flash. To access a specific function, press set until the function is flashing, the features are accessed in the following order:

- Channel
- RF Power
- Unbalanced Input Level
- Balanced Input Option
- Balanced Input Level

CHANNEL SELECTION: Turn the ST-300 on by touching the POWER button. (The ST-300 is designed to return to "on" if power is disconnected while the unit is on. This is so the unit can be switched on and off with a power strip or rack power).

The LCD display will light up and show the Channel, Audio Meter, Frequency (and E.D.R. if it has been enabled). Press the SET button once and Channel letter will flash. Use the UP and DOWN Arrow buttons to select the desired channel A-Q. Press SET when the desired channel is displayed and the channel is set. The channel letter will stop flashing and the RF Power indicator will flash.

RF POWER SELECTION: While the RF Power indicator is flashing, press the UP ARROW for HIGH and DOWN for NORM (the RF Power line will not be displayed). NORM power should be used for small to medium sized venues and whenever multiple systems are being used. Press SET when the power is set and the Unbalanced Input level will flash.

UNBALANCED INPUT LEVEL

ADJUSTMENT: If the unbalanced audio input will not be used, with the Unbalanced Input Level flashing use the UP button to set the level to OFF and press set to go to Balance Input Selection.

If the Unbalanced input will be used, connect the input now and apply audio content. With the audio content playing and Unbalanced Input level flashing, watch the audio meter. The peak signal should not go above the 0 dB segment, use the UP and DOWN buttons to adjust the input level so that the loudest input lights up the 0 dB segment. When the level is set, press the SET button and one of the Balanced Input Options will flash (default is 70V).

BALANCED INPUT SELECTION: If the balanced audio input will not be used, with one of the Balance Input Options flashing press SET so the Balanced Input Level is flashing. Use the UP and DOWN buttons to set the level to OFF and press SET to end the setup session.

If the Balanced input will be used, with one of the options flashing use the UP and DOWN buttons to select the correct input. With the correct input displayed, press SET and the Balanced Input Level indicator will flash.

CAUTION: Permanent damage can result if 70V line is used with the Input Selection improperly set.

BALANCED INPUT LEVEL ADJUSTMENT:

Make sure the Balanced Input Selection is set correctly, then connect the input and apply audio content. With the audio content playing and Balanced Input level flashing, watch the audio meter. The peak signal should not go above the 0 dB segment, use the UP and DOWN buttons to adjust the input level so that the loudest input lights up the 0 dB segment. When the level is set, press the SET button and the Setup Session will end.

Enhanced Dynamic Range (E.D.R.) Operation

The Telex ST-300 Transmitter is equipped with E.D.R., Enhanced Dynamic Range (companded) audio. This mode greatly improves the Audio Signal to Noise Ratio when used with the Telex Model SR-400 receiver. The E.D.R. mode must be selected on both the transmitter and receiver to be effective.

1. To engage the E.D.R. function, turn the ST-300 off with the power switch.
2. Press and hold the SET button while you turn the ST-300 back on. The E.D.R. symbol will be displayed in the lower right corner to indicate the mode is active.
3. Repeat the procedure to disable the E.D.R function.

Change Lock Out

The ST-300 SET button can be locked to prevent E.D.R. activation, and unintended channel changes.

1. To engage the Lock Out Feature, press the UP and DOWN buttons at the same time and hold them down for 10 seconds.
2. The padlock symbol will appear and the set button is disabled.
3. To unlock the system, press the Up and DOWN buttons and hold them for 10 seconds or until the padlock symbol disappears.

AUDIO MONITOR: Turn the Monitor (volume) control all the way down (counterclockwise). After the audio input levels have been adjusted, Stereo headphones with a ¼ in. plug can be plugged into the Monitor jack. If you wish to monitor the audio program material, turn up the monitor (volume) control to the desired level. The monitor control does not affect the transmitted audio level.

Problem	Solution
Transmission sounds compressed on SR-50 or SR-400	E.D.R. function may be engaged on the ST-300. See setting E.D.R. function on page 9. The E.D.R. feature can only be used with the SR-400 and must be active on both transmitter and receiver to be effective.
SET button does not work, cannot change channel	Lock Out is engaged, press and hold UP and DOWN buttons until the padlock symbol disappears.

MULTIPLE SYSTEM INSTALLATIONS: As with any radio device, interference can occur at any time. The frequencies offered are shared with other legitimate users. The severity of interference varies with the distance to the interfering station. Multiple systems further complicate installations. The following steps are suggested in order to achieve best results in your installation.

1. In order to determine whether your selected frequencies have minimum interference, Telex recommends that you first temporarily install the receivers in your proposed setting and monitor the channel for interference. To do this (with fresh batteries installed) turn on your receiver, but DO NOT turn on any other receiver or transmitter at this time. If audible interference is present, this may indicate another user on the channel. Monitoring should be repeated for each channel that you propose to use. DO NOT use channels that have interference.
2. Set your transmitter(s) to channels with no or minimum interference. Each transmitter must be set to a separate frequency. For best results when using multiple transmitters, each transmitter should be installed separately as far as possible from the others.
3. Turn on the transmitter(s) with an active audio input. Test walk a receiver through the expected listening area to verify coverage. The system should now be ready for use.

EQUIPMENT OPERATION

SR-50 SYNTHESIZED RECEIVER

Operation of the SR-50 Receiver

Try to keep a clear, unobstructed path between the transmitter and receiver antennas for clear reception.

Plug in a unit such as an earphone, headphone button receiver, induction coil neckloop, or audio-input hearing aid into the headphone jack. (The cord acts as a receiving antenna.)

Rotate the VOLUME OFF/ON control slowly in the clockwise direction while monitoring the volume level.

When satisfied with the volume level, place the Receiver in a pocket or clip it to your belt for convenience.

Always return the VOLUME OFF/ON control to the OFF position when the receiver is not in use to preserve battery life and prevent battery leakage.

SR-400 SYNTHESIZED RECEIVER

Operation of the SR-400 Receiver

Try to keep a clear, unobstructed path between the transmitter and receiver antennas for a clear transmission.

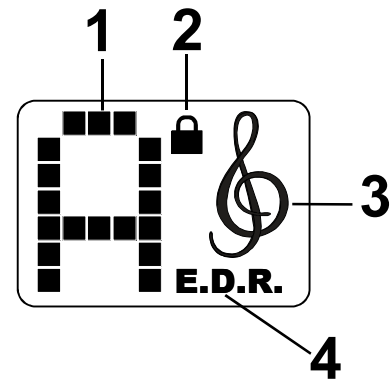



Figure 8
SR-400 Display

1. Channel Display A through Q and low battery indicator
2. Lock Indicator (see Change Lock Out)
3. High Frequency Emphasis Indicator (on when symbol is showing)
4. Enhanced Dynamic Range Indicator.

Channel Selection

1. Turn the receiver on and plug a listening device into the headphone jack. A channel letter will show in the display.
2. Press the set button once and the Channel indicator will flash.
3. Press the  button and the Channel will cycle up, match the channel to the transmitter being used (ST-200, ST-300, PST-16, or PST-170).
4. Press SET, the channel indicator will stop flashing and the channel is set.



Enhanced Dynamic Range (E.D.R.) Operation

The Telex ST-300 and PST-170 Transmitters are equipped with E.D.R., Enhanced Dynamic Range (companded) audio. This mode greatly improves the Audio Signal to Noise Ratio when used with the Telex Model SR-400 receiver. The E.D.R. mode must be selected on both the transmitter and receiver to be effective.

1. To engage the E.D.R function turn the SR-400 off with the volume control thumb wheel.
2. Press and hold the SET button while you turn the SR-400 back on. The E.D.R. symbol will be displayed in the lower right corner to indicate the mode is active.
3. Repeat the procedure to disable the E.D.R. function.

Change Lock Out

The SR-400 SET button can be locked to prevent E.D.R. activation, and unintended channel changes. The High Frequency Emphasis button will remain active at all times for the convenience of the user.

1. To engage the Lock Out Feature, press the SET and  buttons at the same time and hold them down for 10 seconds.
2. The padlock symbol will appear and the set button is disabled.
3. To unlock the system, press the SET and  buttons and hold them for 10 seconds or until the padlock symbol disappears.

Low Battery Indication

1. When there is approximately 10% of the battery life left, a battery symbol will flash alternately with the channel letter in the LCD display.
2. When there is only 5% battery life left, the battery symbol will constantly flash in the display.

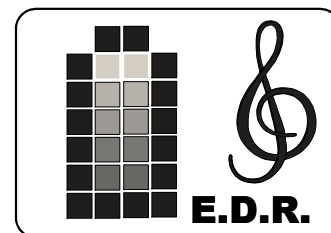

Low Battery Display

BATTERY REPLACEMENT

The SR-50 and SR-400 Receivers use two (2) AA batteries. When the batteries are low the sound will be distorted. Replace weak batteries with two fresh AA batteries, and position them in the battery compartment as illustrated in Figure 9.

For additional information refer to the “Battery Information” Section.

NOTE: If the unit is to be stored for any length of time make sure you remove the batteries from the unit.

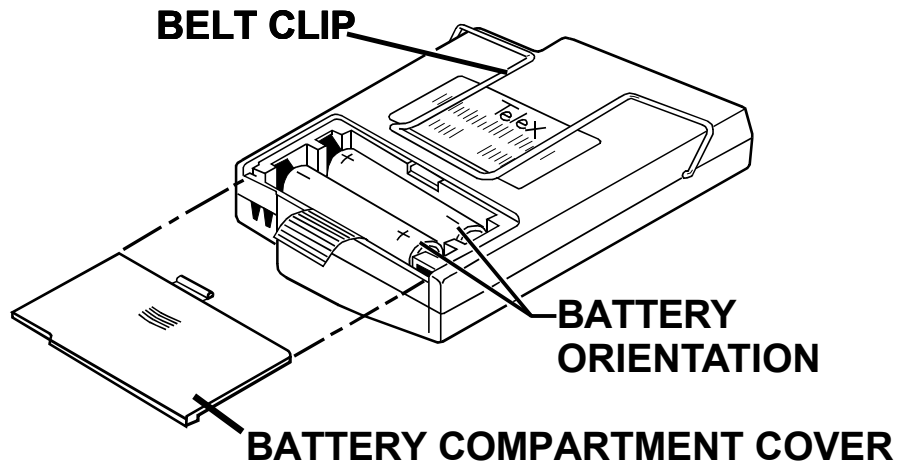

Figure 9
Battery Installation - SR-50 and SR-400

BATTERY INFORMATION

General

Improper battery selection, use, installation and care are the cause of numerous wireless system failures.

Alkaline Batteries

Alkaline batteries such as Mallory's DURACELL® or Eveready's ENERGIZER® provide the most reliable operation in wireless transmitters and receivers. The use of low cost carbon-zinc batteries is NOT RECOMMENDED.

*ENERGIZER® is a registered trademark of Union Carbide Corporation.

*DURACELL® is a registered trademark of Duracell Inc.

ANTENNA INFORMATION

Antenna Alignment

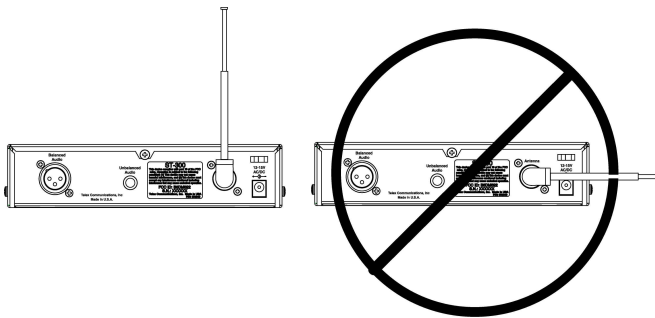

Figure 10
Antenna Alignment
Good and Bad

Antenna Placement

Proper antenna placement probably has the most effect on your TELEX Wireless System's overall performance. Following the suggestions that follow should result in "dropout free" performance.

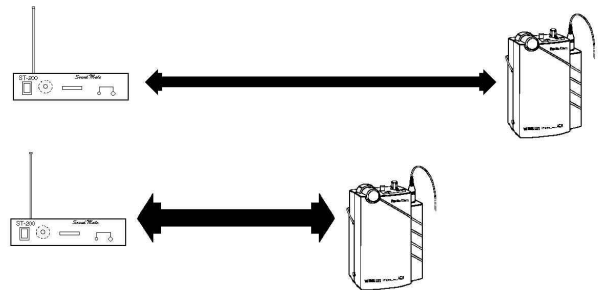
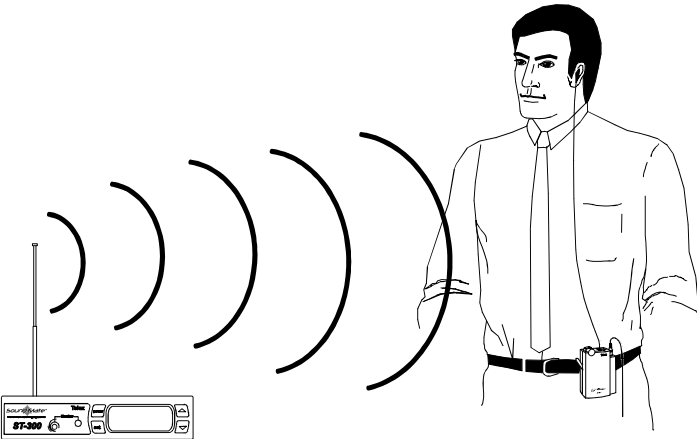

Figure 11
Distance Between Transmitter and Receiver

-----Keep the distance between the transmitter and the receiver(s) as short as possible. The greater the distance the weaker the signal.

Make sure the “signal path” between the transmitter and receiver(s) is unobstructed. You should always be able to visually locate the antenna of the transmitter at all times.



SIGNAL REACHES ANTENNA AT FULL STRENGTH WITH NO OBSTRUCTIONS.

Figure 12
Keeping Site Clear to Antenna

Attempting to operate the sound enhancement system through or around walls, ceilings, metal objects, etc., will reduce system range and performance.

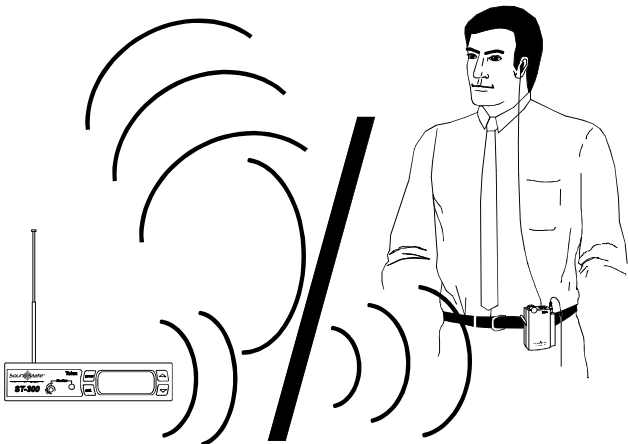

SIGNAL REFLECTION OFF A METAL OBSTRUCTION CAUSES REDUCED SIGNAL AND “MULTIPATH”

Figure 13
Operating Through Obstruction

DO NOT - Mount the transmitter on, or next to, metal such as beams, walls with metal studs, etc. This will “detune” the transmitter antenna which can result in loss of signal at the receiver.

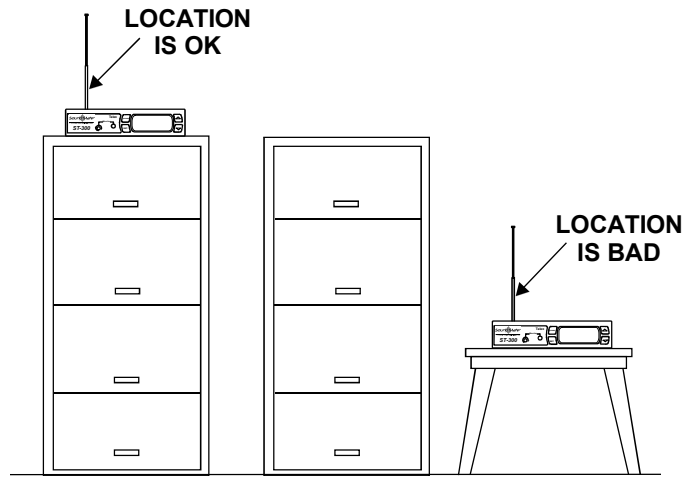

Figure 14
Transmitter Antenna Placement

TROUBLESHOOTING

Reread the sections of this manual to make sure you have completed system set-up properly.

If you are unable to solve the problem, contact the dealer from whom you purchased the system for assistance.

PROBLEM	SOLUTION
DISTORTION -System's audio quality seems distorted at medium to high input levels	Reduce audio gain on transmitter by adjusting the gain controls.
HISS - System seems to produce a "hiss" which is undesirable.	Check the gain settings on the transmitter and the volume control on the receiver. They may be too low.
DROPOUTS - When moving around the area in which you will be using the system there seem to be locations where the signal "swooshes" or completely disappears.	Make sure the antenna is connected and fully extended. Follow the location suggestions on page 15. Change the location of the transmitter antenna or avoid the bad area with the receivers.
INTERFERENCE - System picks up signals other than the ST-300 Transmitter.	Make sure the Telex ST-300 is turned on - this will usually eliminate the interference signal. If problem persist with the transmitter "ON", try changing to another channel.
REDUCED DISTANCE - System doesn't operate as far as it once did. System doesn't operate as well as you think it should.	Receiver Battery is possibly in need of replacement. Transmitter antenna possible located incorrectly. Receiver not tuned properly.
BATTERIES DON'T LAST	If using "throw away" batteries make sure they are alkaline. If using nickel-cadmium or nickel metal hydride batteries make sure they were fully charged when you are using them and fully drained when you are done before recharging them.
HUM - Audio System emits hum or buzz thru speakers and sound enhancement receiver.	Locate Transmitter away from the audio equipment.

CUSTOMER SERVICE INFORMATION

If your receiver or transmitter should need servicing under the warranty, please contact:

Customer Service Department
TELEX COMMUNICATIONS, INC.
8601 East Cornhusker Highway,
P.O. Box 5579,
Lincoln, Nebraska 68505-5579 U.S.A.
Phone: (402) 467-5321 or 465-7021

All claims of defect or shortage should be sent to the above address. When returning items for service, you must provide date and proof of purchase, such as a copy of the sales receipt, to establish warranty. A letter should be included outlining all symptoms and claimed defects. Information on how the equipment was installed and used is very helpful. Please include your phone number and return address in case our service technicians need to contact you.

Units that have been modified cannot be accepted for repair.

Include all information requested by the Service Department. Then pack the unit as follows:

Check the unit to see that all parts and screws are in place. Then wrap it in heavy paper or put it in a plastic bag. If the original carton is not available, place the unit in a strong carton that is at least six inches bigger in all three dimensions than the unit. Fill the carton equally around the unit with resilient packing material (shredded paper, foam, etc.). Seal it with gummed paper tape, tie it with a strong cord, and ship it by prepaid express, United Parcel Service or insured parcel post to the Telex Service Department.

It is very important that the shipment be well-packed and fully insured. Damage claims must be settled between you and the carrier and this can delay repair and return of the unit to you.

Telex reserves the right to make changes in design and improvement on its product without assuming any obligation to install the same on any of its products previously manufactured. Further Telex reserves the right to ship new and/or improved products which are similar to the form, fit and function of products originally ordered.

FCC INFORMATION

The Telex SR-50 Receiver, and SR-400 Receiver are authorized under part 15 of the FCC Regulations. Changes or modifications to this equipment could void the user's authority to operate the equipment.

The Telex Model ST-300 Transmitter is authorized under Federal Communications Commission and Industry Canada Rules. Licensing of the Transmitter, if required, is the users responsibility and licensability depends upon the users classification, and frequency selected.

CAUTION: Changes or modifications made by the user could void the user's authority to operate the equipment.

Operation is subject to the following two conditions: (1) This device may not cause interference, and (2) This device must accept any interference, including interference that may cause undesired operation of the device.

ACCESSORIES and PARTS

Rack Mounting Kit

RM-S for mounting one ST-300.....	71081-001
RM-D for mounting two ST-300's	71081-002

Earphone (for SR-400 and SR-50)

(single)	59840-005
----------------	-----------

Earphone (for SR-400 and SR-50)

(dual).....	59840-001
-------------	-----------

Collapsible Lightweight Headphone (for SR-400 and SR-50)

(dual)).....	59840-007
--------------	-----------

NL-4S

Induction Coil Neckloop.....	71120001
------------------------------	----------

Antenna, Telescoping

for ST-300	877960-1
------------------	----------

Belt Clip

for SR-50 and SR-400	358815
----------------------------	--------

Power Supply

for ST-300	730139
------------------	--------

TELEX[®]

TELEX COMMUNICATIONS, INC. 12000 Portland Ave. South, Burnsville, MN 55337, U.S.A.

PN 804018 Rev. D

SEPT 2005

Made in U.S.A.