

# PRO-T-SHORT-T

*Pro Series Microphone Stand with Patented Quarter-turn Clutch, Short Tripod Base, and Telescoping Boom*

## Durable Construction

All Pro series microphone stands feature oversized, thick, steel tubing and rubber foot caps that won't fall off. What's more, Pro series mic stands resist scratches and won't rust thanks to a heavy-duty, strong (20 times stronger than the competition), Powder Coated finish.

## Heavy-duty, Secure Clutch

The patented Quarter-Turn Clutch on the Pro series microphones is a super smooth design that locks and unlocks with only a quarter turn of the clutch handle. It's an over-molded clutch that delivers a secure grip that locks up faster and smoother than any other clutch on the market.

## Patented Universal Mic Attachment

Whether you're performing in the States or over seas, a Pro series microphone stand is the only stand you'll need. The top threads fit both US- and metric-threaded mic clips and accessories for use all around the world.

## Field-replaceable Parts

The majority of the parts on Pro series microphone stands can be field serviced with replacement parts as needed over their VERY long lifespan.

## Die-cast Tripod Base

The durable and strong, black, chrome-plated die-cast tripod base on the Pro series microphone stands is up to 30 times stronger than the competition's base. And the super strong tripod legs securely snap into place for easy storage and quick setup and take down.

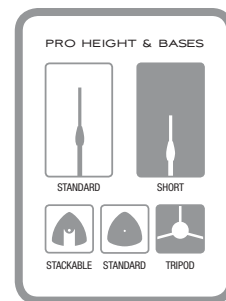

The entire stand uses oversized and heavy walled steel tubing for exceptional durability.

Super smooth Quarter-Turn Clutch allows the user to lock and unlock the clutch with only a quarter turn of the clutch handle.

Die-cast, chrome-plated base with heavy-duty tripod legs, foot caps that are internally and externally attached.

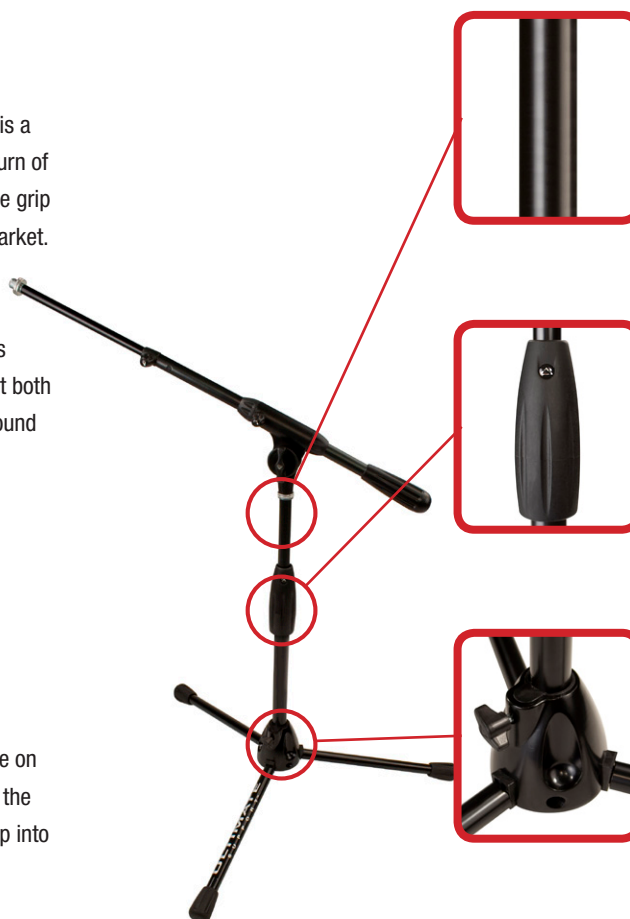

# PRO-T-SHORT-T SPECS

- PRO-T-SHORT-T #17212—black
- Height 19.3" - 30"  
(490 mm - 760 mm)
- Tube diameter 1" (25 mm)
- Weight 8.35 lbs.
- Base footprint 23.75" x 23.75"  
(603 mm - 603 mm)

### Base footprint:

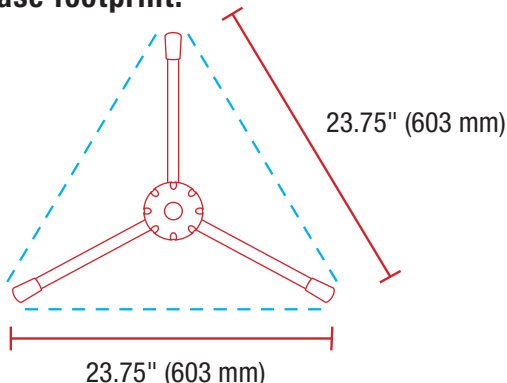

### Telescoping Ulti-boom:

- ULTI-BOOM-TB #17203—black
- Boom length 18.9" - 34.6"  
(480 mm - 880 mm)
- Weight 1.75 lbs.



# PRO-SERIES

The Pro Series microphone stands from Ultimate Support are designed for the gigging musician, working engineer, and professional venue. As the workhorse of the Ultimate Support line of microphone stands, they feature field-replaceable parts that are strong and durable, an easy-to-use, comfortable clutch, and a scratch-resistant finish that will not rust. Pro Series mic stands are available with tripod, weighted, and stackable bases; short, and regular heights; and, with or without telescoping or fixed-length boom arms. There's a Pro Series mic stand for all needs!



**Pro-SB**  
Stackable Weighted Base



**Pro-ST**  
Standard Weighted Base



**Pro-T**  
Tripod Base



**Pro-T-T**  
Tripod Base with Fixed-length Boom



**Pro-T-F**  
Tripod Base with Telescopic Boom



**Pro-T-SHORT-T**  
Tripod Base with Telescopic Boom



**Pro-T-SHORT-F**  
Tripod Base with Fixed-length Boom

**ULTIMATE**  
SUPPORT  
LIMITED LIFETIME WARRANTY