

Color Video Camera

Technical Manual



EVI-D80N/P/D90N/P

Table of Contents

Features	3
Connection	4
Locations of Controls	5
Basic Functions	8
Overview of Functions.....	8
Initial Settings and Position Preset.....	15
Mode Condition	16
Command List	21
VISCA ¹⁾ RS-232C Commands.....	21
EVI-D80N/D80P/D90N/D90P Commands.....	29
D70 Mode	43
Overview	43
Switching the Mode	43
Accepting or Sending Back Commands.....	44
Translating Parameters.....	45
Specifications	47
Precautions	50

Features

- An EX-view HAD™ CCD features 380,000 (NTSC) or 440,000(PAL) effective picture elements and high-sensitivity shooting. The minimum illumination required is 0.7 lx (1/60 sec. (NTSC), 1/50 sec. (PAL), ICR OFF). (EVI-D90N/D90P)
- A CCD features 380,000 (NTSC) or 440,000 (PAL) effective picture elements and high-sensitivity shooting. The minimum illumination required is 0.4 lx (1/60 sec. (NTSC), 1/50 sec. (PAL)). (EVI-D80N/D80P)
- The EVI-D90N/D90P are equipped with a bright zoom lens with 28× optical zoom and F1.35 aperture.
- The EVI-D80N/D80P are equipped with a bright zoom lens with 18× optical zoom.
- A newly-developed Processor provides high resolution images.
- By adopting its wide and dynamic range functions, you can see the optimised shooting image which incorporates bright and dark subjects at the same time. (EVI-D90N/D90P)
- 3D Low-noise images can be obtained even in low-light environments using the Noise Reduction function.
- Adopts the industry standard RS-232C interface of VISCA camera protocol in external communication. It is possible to operate from long distances by using both RS-232C and RS-422.
- You can install the camera on ceilings due to the functions of high-speed and wide range pan/tilt action and vertical image flip.
- You can use the infrared remote commander to set the camera and also to select panning, tilting and zooming from the setting menu.
- You can store up to 6 kinds of camera direction and camera status into the camera.

Connection

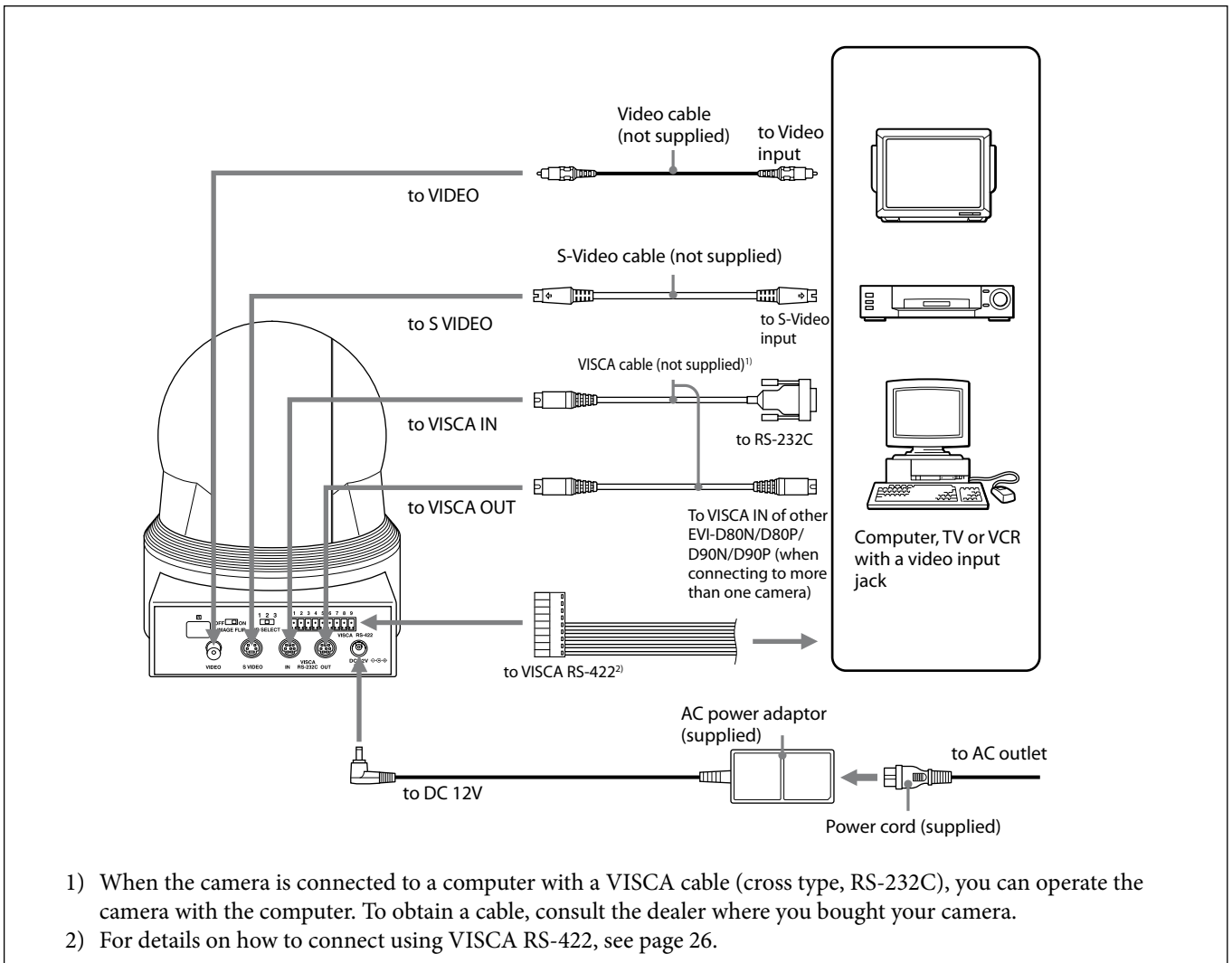

Notes

- You cannot connect your Color Video Camera to a computer that is not equipped with either video input or an S-Video input connector. You might not be able to use your existing computer with your Color Video Camera unless you provide the computer with a video capture board and/or software. Consult your computer dealer or manufacturer for details.

- Use only the AC power adaptor (JEITA type4) supplied with the unit. Do not use any other AC power adaptor.



Polarity of the plug

- Do not make VISCA RS-232C and RS-422 connections at the same time, as this may cause malfunctions.

Locations of Controls

Main Unit

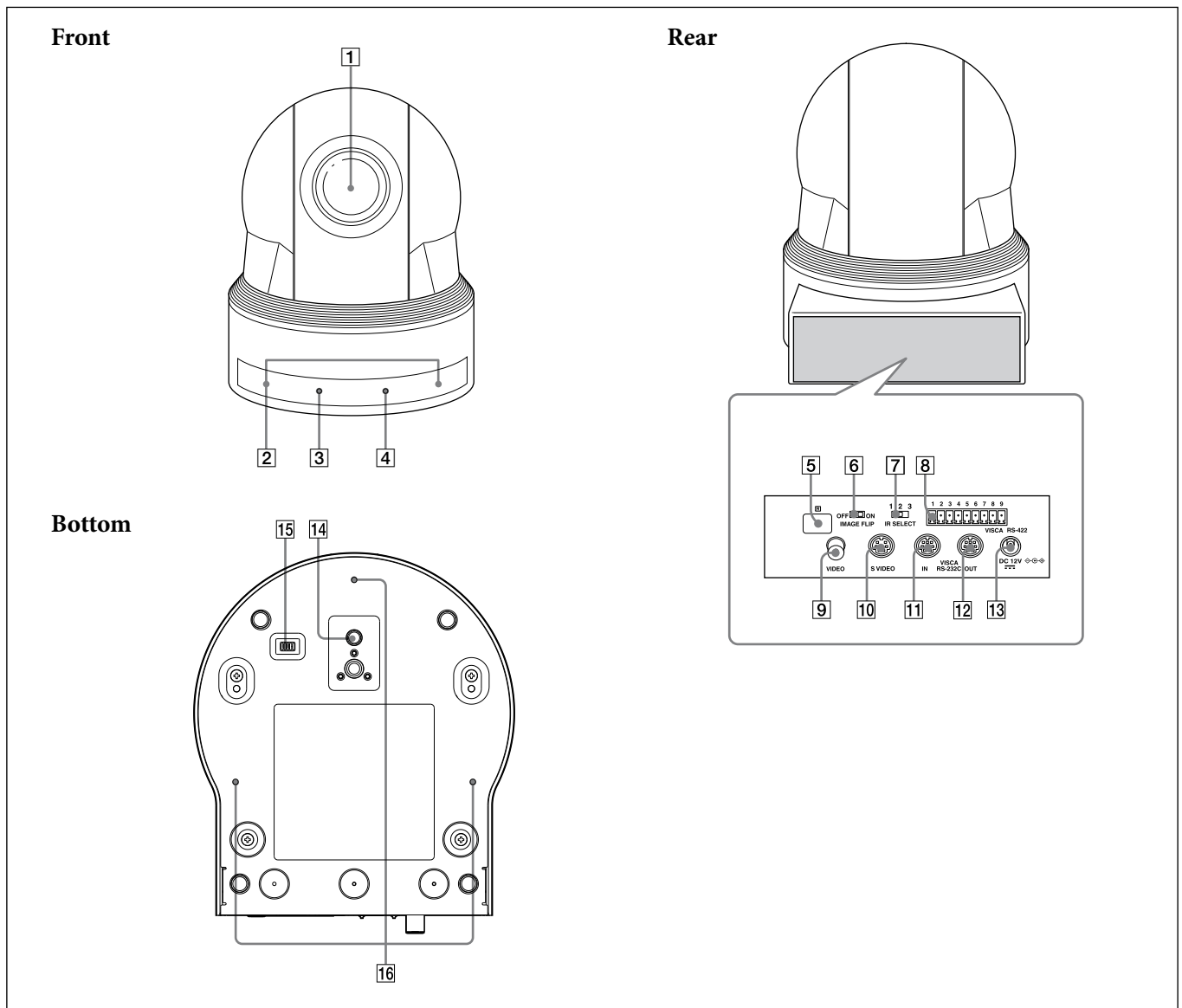

- 1 Lens
- 2 Remote sensors
- 3 POWER lamp

- 4 **STANDBY lamp**
For detailed information on LED status of the POWER lamp and STANDBY lamp, see "LED Status" on page 42.

- 5 Remote sensors

(Continued)

6 IMAGE FLIP switch

Flips the image upside down. Normally set this to OFF when you use the camera. When the camera is attached to the ceiling, set this to ON. Before you set the IMAGE FLIP switch, turn off the unit (or set to standby mode) and then, turn the power on by connecting the power adaptor, by VISCA control or the remote commander. When you switch this, the preset setting is returned to the initial setting. It takes about 7 to 14 seconds for the image displayed to respond to the setting change.

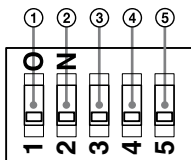
7 IR SELECT switch**8 VISCA RS-422 connector****9 VIDEO(output) connector****10 S VIDEO(output) connector****11 VISCA IN connector****12 VISCA OUT connector****13 DC 12V connector****14 Tripod screw hole****15 BOTTOM switches****1 D70 mode switch**

Set to ON to use the VISCA command for EVI-D70/D70P.

2 IR OUT switch

Set to ON to enable output of the receiver signals, which are transmitted from the infrared remote commander via the VISCA IN connector (page 25), or set it to OFF to disable the output.

3 RS-232C/RS-422 select switch

Set to ON to operate colour video camera using the VISCA command via the RS-422 interface. To change the mode, turn off the camera (not including standby mode) first, set the switch and then turn on the camera again. Mode switching is not possible while the camera is turned on.

4 Baud rate select switch

Set to ON for 38,400 bps or OFF for 9,600 bps. To change the mode, turn off the camera (not including standby mode) first, set the switch and then turn on the camera again. The mode cannot be switched while the camera is turned on.

5 Switch 5 (Not used)

Be sure to set this switch to OFF.

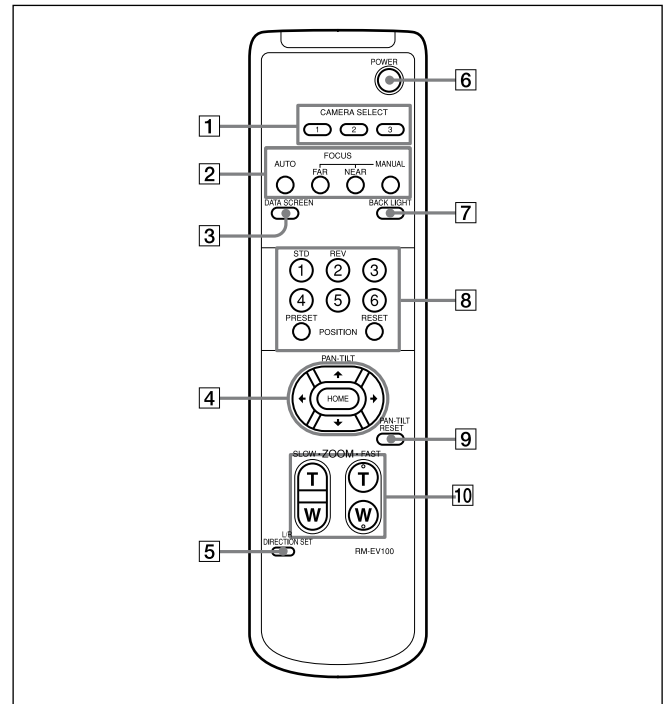
16 Ceiling bracket mounting screw holes**Remote Commander****1 CAMERA SELECT buttons**

Press the button corresponding to the camera you want to operate with the Remote Commander.

The camera number can be set using the IR SELECT switch on the rear of the camera.

Note

If two or more cameras are adjacent and have the same camera number, they are operated simultaneously with the same Remote Commander. When you install the cameras close to each other, set different camera numbers.

For the camera number setting, see "Operating Multiple Cameras with the Remote Commander" described in the Operating Instructions supplied with the camera.

2 FOCUS buttons

Used for focus adjustment.

Press the AUTO button to adjust the focus automatically. To adjust the focus manually, press the MANUAL button, and adjust it with the FAR and NEAR buttons.

3 DATA SCREEN button

Press this button to display the main menu. Press it again to turn off the menu. If you press the button when a lower-level menu is selected, the display goes back to a higher-level menu.

Note

Pan/tilt operations are disabled when the menu is displayed.

4 PAN-TILT buttons

Press the arrow buttons to perform panning and tilting.
Press the HOME button to face the camera back to the front.
When the menu is displayed, use \uparrow or \downarrow to select the menu items and \leftarrow or \rightarrow to change the set values. The selected setting menu is displayed, by pressing the HOME button when the main menu is displayed.
The Pan/tilt speed will slow down when the camera is zoomed, in order to allow precise positioning.

5 L/R DIRECTION SET button

Hold down this button and press the REV button to change the direction of the camera movement opposite to that indicated by the arrow of the \leftarrow/\rightarrow buttons.
To reset the direction of the camera movement, press the STD button while holding down this button.

6 POWER switch

Press this button to turn on/off the camera when the camera is connected to an AC outlet.

7 BACK LIGHT button

Press this button to enable the backlight compensation.
Press it again to disable the backlight compensation.

8 POSITION buttons

Hold down the PRESET button and press button 1 to 6 to store the current camera direction, zooming, focus adjustment and backlight compensation in the memory of the pressed number button.
To erase the memory contents, hold down the RESET button and press button 1 to 6.

Note

These buttons do not function when the menu is displayed.

9 PAN-TILT RESET button

Press this button to reset the pan/tilt position.

10 ZOOM buttons

Use the SLOW button to zoom slowly, and the FAST button to zoom quickly.
Press the T (telephoto) side of the button to zoom in, and the W (wide angle) side to zoom out

Basic Functions

Overview of Functions

Zoom

EVI-D80N/P:

The camera employs a 18× optical zoom lens combined with a digital zoom function; this camera allows you to zoom up to 216×.

- **Optical 18×, f = 4.1 mm to 73.8 mm (F 1.4 to F 3.0)**

The horizontal angle of view is approximately 48.0 degrees (wide end) to 2.8 degrees (tele end). Digital Zoom enlarges the center of the subject by expanding each image in both the vertical and horizontal directions. When 216× zoom is used, the number of effective picture elements in each direction reduces to 1/12 and the overall resolution deteriorates.

EVI-D90N/P:

The camera employs a 28× optical zoom lens combined with a digital zoom function; this camera allows you to zoom up to 336×.

- **Optical 28×, f = 3.5 mm to 98.0 mm (F 1.35 to F 3.7)**

The horizontal angle of view is approximately 55.8 degrees (wide end) to 2.1 degrees (tele end). Digital Zoom enlarges the center of the subject by expanding each image in both the vertical and horizontal directions. When 336× zoom is used, the number of effective picture elements in each direction reduces to 1/12 and the overall resolution deteriorates.

You can activate the zoom in the following two ways

- **By pressing the ZOOM buttons on the Remote Commander**
- **Using a VISCA Command**

Using Standard Mode

Using Variable Mode

There are eight levels of zoom speed.

Direct Mode

Setting the zoom position enables quick movement to the designated position.

Digital Zoom ON/OFF

In these standard and variable Speed Modes, it is necessary to send Stop Command to stop the zoom operation.

Focus

Focus has the following modes, all of which can be set using VISCA Commands.

- **Auto Focus Mode**

The minimum focus distance is 10 mm at the optical wide end and 800 mm (EVI-D80N/P), 1500 mm (EVI-D90N/P) at the optical tele end, and is independent of the digital zoom. The Auto Focus (AF) function automatically adjusts the focus position to maximise the high frequency content of the picture in a center measurement area, taking into consideration the high luminance and strong contrast components.

- Normal AF Mode

This is the normal mode for AF operations.

- Interval AF Mode

The mode used for AF movements carried out at particular intervals. The time intervals for AF movements and for the timing of the stops can be set in one-second increments using the Set Time Command. The initial value for both is set to five seconds.

- Zoom Trigger Mode

When the zoom is changed with the ZOOM buttons on the Remote Commander, the pre-set value (initially set at 5 seconds) becomes that for AF Mode. Then, it stops.

AF sensitivity can be set to either Normal or LOW.

- Normal

Reaches the highest focus speed quickly. Use this when shooting a subject that moves frequently. Usually, this is the most appropriate mode.

- LOW

Improves the stability of the focus. When the lighting level is low, the AF function does not take effect, even though the brightness varies, contributing to a stable image.

- **Manual Focus Mode**

Manual Focus has both a Standard Speed Mode and a Variable Speed Mode. Standard Speed Mode focuses at a fixed rate of speed. Variable Speed Mode has eight speed levels that can be set using a VISCA Command.

In these standard and variable Speed Modes, it is necessary to send Stop Command to stop the zoom operation.

- **One Push Trigger Mode**

When a Trigger Command is sent, the lens moves to adjust the focus for the subject. The focus lens then holds that position until the next Trigger Command is input.

- **Infinity Mode**

The lens is forcibly moved to a position suitable for an unlimited distance.

- **Near Limit Mode**

Can be set in a range from 1000 (∞) to C000 (10 mm).

Default setting (EVI-D80N/P): 8000h (29 cm)

Default setting (EVI-D90N/P): 9000h (30 cm)

White Balance

White Balance has the following modes, all of which can be set using VISCA Commands.

- **Auto White Balance**

This mode computes the white balance value output using color information from the entire screen. It outputs the proper value using the color temperature radiating from a black subject based on a range of values from 3,000 to 7,500 K.

This mode is the default setting.

- **Indoor**

3,200 K Base Mode

- **Outdoor**

5,800 K Base Mode

- **One Push WB**

The One Push White Balance mode is a fixed white balance mode that may be automatically readjusted only at the request of the user (One Push Trigger), assuming that a white subject, in correct lighting conditions and occupying more than $\frac{1}{2}$ of the image, is captured by the camera.

One Push White Balance data is lost when the power is turned off. If the power is turned off, reset the One Push White Balance.

- **Manual WB**

Manual control of R and B gain, 256 steps each

Automatic Exposure Mode

A variety of AE functions are available for optimal output of subjects in lighting conditions that range from low to high.

- **Full Auto**

Exposure is adjusted automatically by gain, iris and electronic shutter setting.

- **AE Gain Limit Setting**

The gain limit can be set at the Full Auto, Shutter Priority and Iris Priority in the AE mode. Use this setting when image signal-to-noise ratio is particularly important.

- **Shutter Priority ¹⁾**

Variable Shutter Speed, Auto Iris and Gain (1/1 to 1/10,000 sec., 16 high-speed shutter speeds plus 6 low-speed shutter speeds)

1) Flicker can be eliminated by setting shutter to

→ 1/100s for NTSC models used in countries with a 50 Hz power supply frequency

→ 1/120s for PAL models used in countries with a 60 Hz power supply frequency

- **Iris Priority**

Variable Iris (F1.4* to Close, 18 steps), Auto Gain and Shutter speed

- **Manual**

Variable Shutter, Iris and Gain

- **Bright**

Variable Iris and Gain (Close to F1.4*, 17 steps at 0 dB: F1.4*, 15 steps from 0 to 28 dB)

* For EVI-D80N/P this setting is F1.4, EVI-D90N/P is F1.35.

AE – Shutter Priority

The shutter speed can be set freely by the user to a total of 22 steps – 16 high speeds and 6 low speeds.

When the slow shutter is set, the speed can be 1/30s, 1/15s, 1/8s, 1/4s, 1/2s, 1/1s. The picture output is read at a normal rate from the memory. The memory is updated at a low rate from the CCD. AF capability is low. In high speed mode, the shutter speed can be set up to 1/10,000s. The iris and gain are set automatically, according to the brightness of the subject.

Data	NTSC (s)	PAL (s)
15	1/10000	1/10000
14	1/6000	1/6000
13	1/4000	1/3500
12	1/3000	1/2500
11	1/2000	1/1750
10	1/1500	1/1250
0F	1/1000	1/1000
0E	1/725	1/600
0D	1/500	1/425
0C	1/350	1/300
0B	1/250	1/215
0A	1/180	1/150
09	1/125	1/120
08	1/100	1/100
07	1/90	1/75
06	1/60	1/50
05	1/30	1/25
04	1/15	1/12
03	1/8	1/6
02	1/4	1/3
01	1/2	1/2
00	1/1	1/1

AE – Iris Priority

The iris can be set freely by the user to 18 steps between F1.6 and Close.

The gain and shutter speed are set automatically, according to the brightness of the subject.

Data	Setting	value Data	Setting value
11	F1.4*	08	F6.8
10	F1.6	07	F8
0F	F2	06	F9.6
0E	F2.4	05	F11
0D	F2.8	04	F14
0C	F3.4	03	F16
0B	F4	02	F19
0A	F4.8	01	F22
09	F5.6	00	CLOSE

* For EVI-D80N/P this setting is F1.4, EVI-D90N/P is F1.35.

AE – Manual

The shutter speed (22 steps), iris (18 steps) and gain (16 steps) can be set freely by the user.

AE – Bright

The bright control function adjusts both gain and iris using an internal algorithm, according to a brightness level freely set by the user. Exposure is controlled by gain when dark, and by iris when bright.

As both gain and iris are fixed, this mode is used when exposing at a fixed camera sensitivity. When switching from Full Auto or Shutter Priority Mode to Bright

Mode, the current status will be retained for a short period of time.

Only when the AE mode is set to “Full Auto” or “Shutter Priority,” can you switch it to “Bright.”

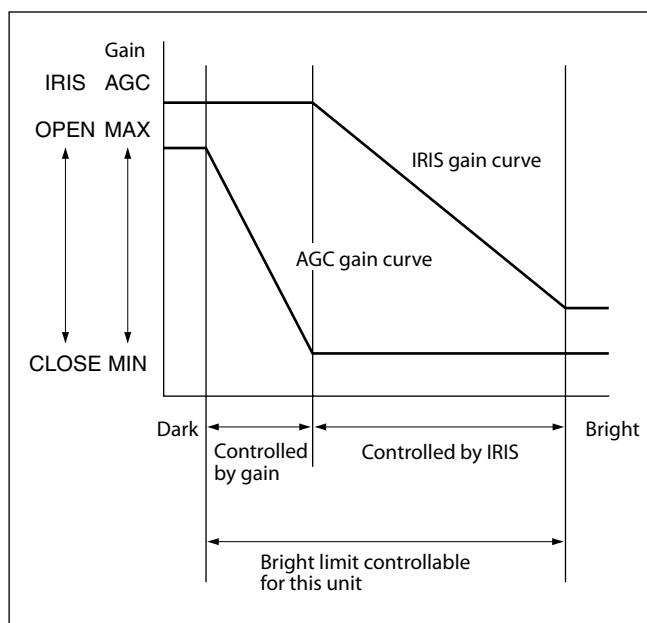

Data	Iris	Gain	Data	Iris	Gain
1F	F1.4*	28 dB	0F	F2	0 dB
1E	F1.4*	26 dB	0E	F2.4	0 dB
1D	F1.4*	24 dB	0D	F2.8	0 dB
1C	F1.4*	22 dB	0C	F3.4	0 dB
1B	F1.4*	20 dB	0B	F4	0 dB
1A	F1.4*	18 dB	0A	F4.8	0 dB
19	F1.4*	16 dB	09	F5.6	0 dB
18	F1.4*	14 dB	08	F6.8	0 dB
17	F1.4*	12 dB	07	F8	0 dB
16	F1.4*	10 dB	06	F9.6	0 dB
15	F1.4*	8 dB	05	F11	0 dB
14	F1.4*	6 dB	04	F14	0 dB
13	F1.4*	4 dB	03	F16	0 dB
12	F1.4*	2 dB	02	F19	0 dB
11	F1.4*	0 dB	01	F22	0 dB
10	F1.6	0 dB	00	CLOSE	0 dB

* For EVI-D80N/P this setting is F1.4, EVI-D90N/P is F1.35.

When switching from the Shutter Priority mode to the Bright mode, the shutter speed set in the Shutter Priority mode is maintained.

Exposure Compensation

Exposure compensation is a function which offsets the internal reference brightness level used in the AE mode by steps of 1.5 dB.

Data	Step	Setting value
0E	+7	+10.5 dB
0D	+6	+9 dB
0C	+5	+7.5 dB
0B	+4	+6 dB
0A	+3	+4.5 dB
09	+2	+3 dB
08	+1	+1.5 dB
07	0	0 dB
06	-1	-1.5 dB
05	-2	-3 dB
04	-3	-4.5 dB
03	-4	-6 dB
02	-5	-7.5 dB
01	-6	-9 dB
00	-7	-10.5 dB

High Resolution Mode

A newly developed ISP function enables the filtering of signals. This allows the camera to provide images with a high resolution.

Aperture Control

Aperture control is a function which adjusts the enhancement of the edges of objects in the picture. There are 16 levels of adjustment, starting from “no enhancement.” When shooting text, this control may help by making the text sharper.

Back Light Compensation

When the background of the subject is too bright, or when the subject is too dark due to shooting in the AE mode, back light compensation will make the subject appear clearer.

Wide Dynamic Range Mode (WD) (EVI-D90N/P only)

The Wide Dynamic Range mode is a function for dividing an image into several blocks and correcting blocked-up shadows and blown-out highlights in accordance with the intensity difference. It enables you to obtain images in which portions ranging from dark to light can be recognized, even when capturing a subject with a large intensity difference that is backlit or includes extremely light portions.

A CCD for shooting a wide dynamic range is employed, and a newly developed image signal processor combines a long exposure signal (normal shutter) and a signal of the high intensity portions obtained by a short exposure (high-speed shutter) to achieve images with a wide dynamic range.

Wide Dynamic Range Auto On/Off Mode

The wide dynamic range can be set to be automatically switched ON/OFF in accordance with the intensity difference obtained by dividing an image into several blocks and then averaging the intensity of each block.

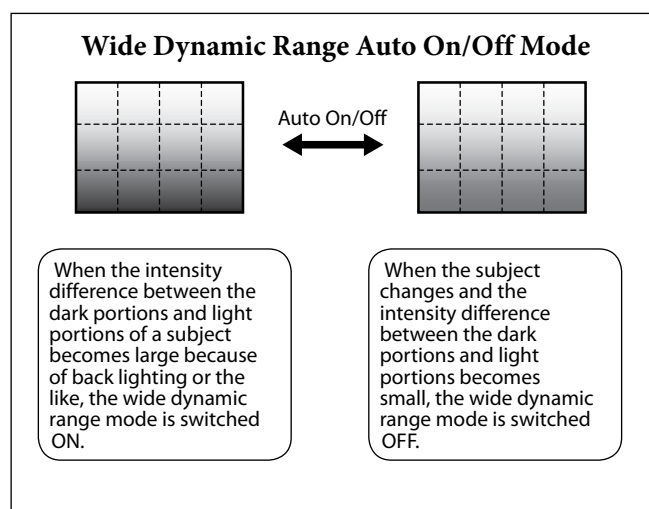

The wide dynamic range mode includes the following operation modes.

- **WD Mode**

This mode corrects blocked-up shadows and blownout highlights in accordance with the intensity difference.

- **WD Auto ON/OFF Mode**

This mode switches WD ON/OFF automatically in accordance with the intensity difference of the subject. Configure the sensitivity for when WD is switched from OFF to ON with the detection sensitivity parameter.

- **Exposure Ratio Mode**

This mode fixes the shutter speed of a short exposure. Configure the shutter speed of a long exposure by setting the ratio with regards to a short exposure with the exposure ratio parameter. Blocked-up shadow correction is not performed in this mode.

- **Histogram Mode**

This mode uses a histogram to correct blocked-up shadows and blown-out highlights.

- **About WD Set Parameter**

(Command: 8x 01 04 2D 0p 0q 0r 0s 0t 0u 00 00 FF)

p: Screen display (0: Combined image, 1: Long/short division, 2: Long-time, 3: Short-time) Set the screen display to a WD combination image, long/short exposure division image, long exposure image, or short exposure image.

q: Detection sensitivity (0: Low, 1: Mid, 2: Hi) Select from three levels for detecting the intensity within the image for when switching Auto WD from OFF to ON.

r: Blocked-up shadow correction level can be set to one of four levels. (0:L 1:M 2:H 3:S)

s: Blown-out highlight correction level can be set to one of three levels. (0:L 1:M 2:H)

tu: Parameter to use in the exposure ratio mode. Specify the short exposure time by setting the magnification ratio (×1 to ×150) with regards to a long exposure time.

Note

When the wide dynamic range mode is ON, solarization may be observed in the images of some subjects. This phenomenon is unique to wide dynamic range mode, and is not an indication of a camera malfunction.

Noise Reduction

The NR (Noise Reduction) function removes noise (both random and non-random) to provide clearer images. By combining 2D filtering according to brightness and image color, and 3D filtering according to noise caused by motion and time difference, lower noise images can be obtained for the corresponding image brightness of a moving subject.

This function has six steps: levels 1 to 5, plus off.

Level 1 applies to subject motion mainly using 2D filter effects. With level 5, 2D and 3D filter effects are maximized, providing the lowest-noise images, although moving subjects may show trails.

At each level, two filters are set according to noise and image motion characteristics, so the available level selections depend on the situation. The default setting is level 3.

Image Stabilizer (EVI-D90N/P only)

Switching ON the Image Stabilizer function reduces image blurring caused by, for example, vibration, which allows you to obtain images without much blurring. A correction effect of approximately 90% is possible for a vibration frequency of around 10 Hz. The Image Stabilizer function employs the digital zoom system, so the angle of view and resolution are changed, but the sensitivity is maintained.

Hold Function of Image Stabilizer

With the Image Stabilizer function, suddenly stopping high-speed movement (pan, tilt, etc.) of the camera produces a blur sensor counteraction that may cause image movement. In such a case, you can use a command setting (hold) to maintain the correction of the Image Stabilizer function. In this case the image stabilizer is off, but there is no change in the angle of view.

Slow shutter – Auto/Manual

When set to “Auto,” ensures that the slow shutter is set automatically when the brightness drops. Effective only when the AE mode is set to “Full Auto.” Set to “Slow Shutter Manual” at shipment.

Note

The Slow Shutter Auto function is not available in WD mode

ICR (IR Cut-Removable) Mode (EVI-D90N/P only)

An infrared (IR) Cut-Filter can be disengaged from the image path for increased sensitivity in low light environments. The ICR will automatically engage depending on the ambient light, allowing the camera to be effective in day/night environments.

When the auto ICR mode is set to ON, the image becomes black and white.

Auto ICR Mode (EVI-D90N/P only)

Auto ICR Mode automatically switches the settings needed for attaching or removing the IR Cut Filter. With a set level of darkness, the IR Cut Filter is automatically disabled (ICR ON), and the infrared sensitivity is increased. With a set level of brightness, the IR Cut Filter is automatically enabled (ICR OFF). Also, on systems equipped with an IR light, the internal data of the camera is used to make the proper decisions to avoid malfunctions.

Auto ICR Mode operates with the AE Full Auto setting.

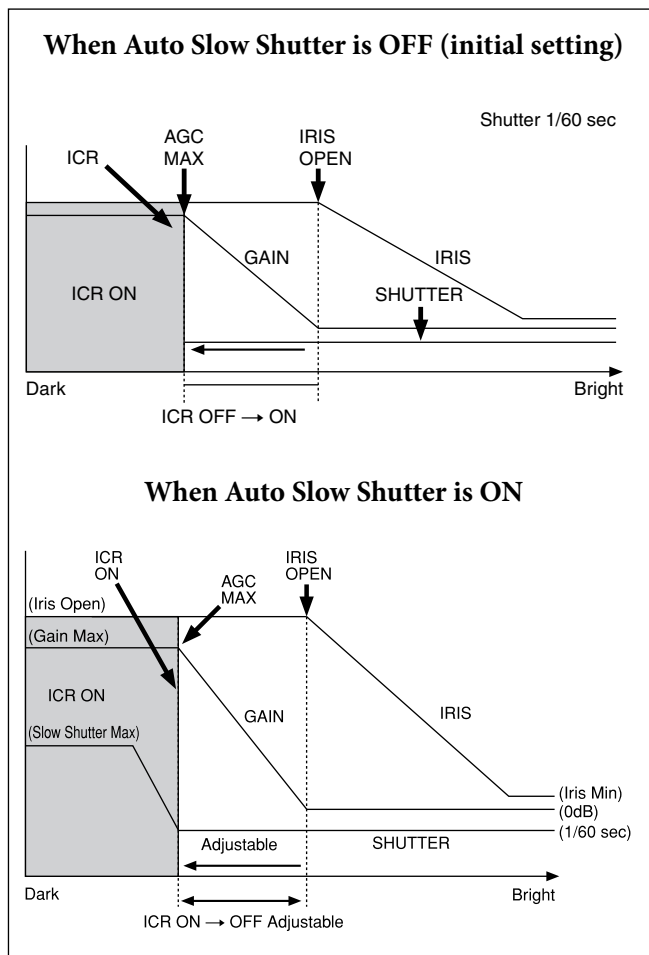

Note

When in Auto_ICR_OFF state and WB data is added (default), a malfunction may occur when the subjects largely consisting of blue and green colors are taken.

Camera ID

The ID can be set up to 65,536 (0000 to FFFF). As this will be memorized in the nonvolatile memory inside the camera, data will be saved regardless of whether it has been backed up.

Effect

It consists of the following functions.

- **Neg. Art:** Negative/Positive Reversal
- **Black White:** Monochrome Image

Checking the Location of the Camera for Signals from the IR Remote Commander

The supplied Remote Commander may not work correctly near inverter lighting fixtures. Good IR detection can be verified to determine proper camera location.

While the camera is being initialized after the power is turned on by connecting the camera to an AC outlet using the AC power adaptor and AC power cord, or by using a VISCA command, the camera detects whether or not the camera is able to receive infrared signals from the Remote Commander. You can check the result of this operation via the IR_ConditionInq command (see page 33).

When the installation location does not allow stable reception, try to install the camera farther away from the inverter lighting fixtures.

Others

Power On/Off

Powers the camera on and off. When the power is off, the camera is able to accept only the lowest level of VISCA Commands and POWER of the Remote Commander; the display and other features are turned off.

I/F clear

Clears the Command buffer of the camera. Clearing the buffer can also be carried out from the control application software when the power is on.

Address set

VISCA is a protocol, which normally can support a daisy chain of up to seven attached devices. Therefore, whenever a camera is connected for the first time, be sure to use the address set to confirm the address.

Memory (Position Preset)

Using the position preset function, 6 sets of camera shooting conditions can be stored and recalled. This function allows you to achieve the desired status instantly without adjusting the following items each time.

- **Pan/Tilt Position**
- **Zoom Position**
- **Digital Zoom On/Off**
- **Focus Auto/Manual**
- **Focus Position**
- **AE Mode**
- **Shutter control parameters**
- **Bright Control**
- **Iris control parameters**
- **Gain control parameters**
- **Exposure Compensation On/Off**
- **Exposure Level**
- **Backlight Compensation On/Off**
- **Slow Shutter Auto/Manual**
- **White Balance Mode**
- **R/B Gain**
- **Aperture**
- **ICR Shoot On/Off (EVI-D90N/P only)**
- **WD On/Off (EVI-D90N/P only)**

The settings are recalled when the power is turned on.

For setting items, see the “Initial Settings, Position Preset” section on page 15.

Note

If the camera is placed on a desk, when you pan the camera to the right or left beyond 120° with the camera tilted downward by 20° (or tilted upward by 20° if it is installed on a ceiling), the camera base may be captured by the lens, depending on the zoom position of the lens.

Initial Settings and Position Preset

The initial values are those set at the factory. Settings for items in Position presets 1 to 6 that will be retained even when the power to the camera is turned off are indicated by a “Yes,” those that will be lost are indicated by an “No.”

- When the power is turned on, the settings retained in POSITION 1 will be called up as the initial settings.
- When a CAM_Memory Reset command is sent, or a

choice is made from POSITION 1 to 6 while the RESET button on the Remote Commander is being pressed, the settings selected will be used as the initial settings.

- Position preset 1 becomes VISCA command CAM_Memory memory number 0. Position presets 2 through 6 become VISCA command CAM_Memory memory numbers 1 through 5.

Mode/Position	Initial settings	Position preset 1	Position presets 2 to 6
Pan/Tilt Position	Home position	○	○
Pan/Tilt Limit Position	movable-range maximum	○	×
Zoom Position	Wide end	○	○
D-Zoom On/Off	on	○	○
Focus Position	—	○	○
Focus Auto/Manual	Auto	○	○
Near Limit Setting	9000h (30 cm)	○	○
AF Sensitivity	Normal	○	○
AF Mode	Normal	○	○
AF Run Time	5 sec	○	○
AF Interval	5 sec	○	○
WB Mode	Auto	○	○
WB Data (Rgain, Bgain)	—	○	○
One Push WB Data	—	○	○
AE Mode	Full Auto	○	○
WD On/Off/Auto	Off	○	○
Slow Shutter Mode	Manual	○	○
Shutter Position	1/60sec (NTSC), 1/50sec (PAL)	○	○
Iris Position	—	○	○
Gain Position	—	○	○
Bright Position	—	○	○
Exposure Compensation On/Off	Off	○	○
Exposure Compensation Amount	±0	○	○
BackLight On/Off	Off	○	○
Aperture Level	6	○	○
High Resolution Mode On/Off	Off	○	○
Picture Effect	Off	○	○
ICR On/Off ¹⁾	Off	○	○
Auto ICR On/Off ¹⁾	Off	○	○
Auto ICR Threshold Level ¹⁾	0Ah	○	○
Image Stabilizer On/Off/Hold ¹⁾	Off	○	○
NR Level	3	○	○
AE Gain Limit	—	○	○
Camera ID	0000h	○	○
IR_Receive On/Off	On	○	×
IR_ReceiveReturn On/Off	Off	○	×
Display Information	On	○	×

1) The setting is available on EVI-D90N/P only.

Notes

- The number of times data can be written to the EEPROM (by executing Position Preset) is limited.
- If you want the camera status and Pan/Tilt positions in effect before the camera is turned off to be retained when the power is turned OFF, then turned ON again, have the camera memorize those positions in POSITION 1.
- It takes approximately 2 seconds longer to memorize or erase settings in POSITION 1 than it does to memorize or erase settings in any other channel.
- Camera ID data will be saved regardless of the position preset.
- If IMAGE FLIP or D70 mode has been switched, all of the Position Presets are reset to their initial values.

Mode Condition

Basic settings

Command	Power Off ¹⁾				Power On			
	Power Off ¹⁾	IFC ²⁾	Initializing ³⁾	During displaying the menu	Memory Command			
Address Set	Yes	Yes	Yes	Yes	Yes			
IF_Clear	Yes	Yes	Yes	Yes	Yes			
CAM_Power On	Yes	No	No	Yes	No			
CAM_Power Off	Yes	No	No	Yes	No			
IR_Receive On/Off	No	No	No	Yes ⁴⁾ , ⁶⁾	No			
IR_ReceiveReturn On/Off	No	No	No	Yes ⁶⁾	No			
CAM_Versionq	Yes	Yes	Yes ⁵⁾	Yes	Yes			
CAM_PowerInq	Yes	Yes	Yes	Yes	Yes			
BlockInquiry	No	No	No	Yes ⁶⁾	No			
InquiryCommand (and similar commands)	No	No	No	Yes ⁶⁾	No			

1) DC power is being supplied, but the camera has been turned off by a VISCA command.

2) The period from the time IF Clear is sent, until the Reply Packet is returned.

3) The period from the time DC power is turned on or the camera is turned on via a VISCA command, and the camera subsequently finishes the pan/tilt reset operation and stops at the Home position, until the video signal is output. Or the period from the time the CAM Power ON command is sent, until Completion is returned.

4) The camera does not receive the operation sent from the Remote Commander.

5) Commands can be executed after the pan/tilt movement has been started. Before that, camera movement may be inconsistent.

6) When the menu display is updating, operation is not possible.

Zoom/Focus

Command	Mode	Power Off ¹⁾	Power On						Memory Recall
			IFC ²⁾	Initializing ³⁾	Zoom Direct	Focus Direct	AF ON	During displaying the menu	
CAM_Zoom Tele/Wide/Stop [VISCA]		No	No	No	Yes	Yes	Yes ⁴⁾	No	
CAM_Zoom Tele/Wide/Stop [RC]		No	No	No	Yes	Yes	Yes ⁴⁾	No	
CAM_Zoom Direct		No	No	Yes	Yes	Yes	Yes ⁴⁾	No	
D-Zoom Limit		No	No	No	Yes	Yes	Yes ⁴⁾	No	
CAM_Focus Far/Near/Stop [VISCA]		No	No	Yes	No	No	Yes ⁴⁾	No	
CAM_Focus Far/Near/Stop [RC]		No	No	Yes	No	No	Yes ⁴⁾	No	
CAM_Focus Direct		No	No	Yes	Yes	No	Yes ⁴⁾	No	
CAM_Focus Mode (Auto/Manual)		No	No	Yes	No	Yes	Yes ⁴⁾	No	
CAM_Focus One Push Trigger		No	No	Yes	No	No	Yes ⁴⁾	No	
CAM_Focus Infinity		No	No	Yes	No	Yes	Yes ⁴⁾	No	
CAM_Focus Near Limit		No	No	Yes	No	Yes	Yes ⁴⁾	No	
AF Sensitivity Normal/Low		No	No	Yes	Yes	Yes	Yes ⁴⁾	No	
AF Mode Norm/Interval/Zoom		No	No	Yes	Yes	Yes	Yes ⁴⁾	No	
AF Activation Time/Interval Setting		No	No	Yes	Yes	Yes	Yes ⁴⁾	No	

1) DC power is being supplied, but the camera has been turned off by a VISCA command.

2) The period from the time IF Clear is sent, until the Reply Packet is returned.

3) The period from the time DC power is turned on or the camera is turned on via a VISCA command, and the camera subsequently finishes the pan/tilt reset operation and stops at the Home position, until the video signal is output. Or the period from the time the CAM Power ON command is sent, until Completion is returned.

4) When the menu display is updating, operation is not possible.

White Balance

Command	Mode	Power Off ¹⁾	IFC ²⁾	Initializing ³⁾	Power On				Memory Recall	
					White balance mode					
					Auto	Indoor	Outdoor	One Push	Manual	During displaying the menu
CAM_WB Auto/Indoor/Outdoor/OnePushWB/Manual		No	No	No	Yes	Yes	Yes	Yes	Yes	Yes ⁴⁾
CAM_WB One Push Trigger		No	No	No	No	No	No	Yes ⁵⁾	No	Yes ⁴⁾
CAM_WB R(B) Gain Reset/Up/Down/Direct		No	No	No	No	No	No	No	Yes	Yes ⁴⁾

1) DC power is being supplied, but the camera has been turned off by a VISCA command.

2) The period from the time IF Clear is sent, until the Reply Packet is returned.

3) The period from the time DC power is turned on or the camera is turned on via a VISCA command, and the camera subsequently finishes the pan/tilt reset operation and stops at the Home position, until the video signal is output. Or the period from the time the CAM Power ON command is sent, until Completion is returned.

4) When the menu display is updating, operation is not possible.

5) Commands are ignored during a One Push AWB operation.

Exposure

Command	Mode	Power Off ¹⁾	IFC ²⁾	Initializing ³⁾	Power Off							Wide-D ON ⁸⁾	During displaying the menu	Memory Recall
					Exposure mode				Manual					
					Full Auto	Bright	Shutter Pri	Iris Pri		SPOT Light				
CAM_AE Full Auto/Manual/Shutter Pri/Iris Pri/Spot Light		No	No	No	Yes ⁴⁾	Yes	Yes	Yes	Yes	Yes	Yes	Yes ⁵⁾	No	
CAM_AE Bright		No	No	No	Yes	Yes	No	No	No	No	No	Yes ⁵⁾	No	
CAM_Slow Shutter Limit ON/OFF		No	No	No	Yes	Yes	Yes	Yes	Yes	Yes	Yes	Yes ⁵⁾	No	
CAM_Shutter Reset/Up/Down/Direct		No	No	No	No	No	Yes	No	No	No	Yes	Yes ⁵⁾	No	
CAM_Iris Reset/Up/Down/Direct		No	No	No	No	No	No	Yes	No	No	Yes	Yes ⁵⁾	No	
CAM_Gain Reset/Up/Down/Direct		No	No	No	No	No	No	No	No	No	Yes	Yes ⁵⁾	No	
CAM_Bright Up/Down/Direct		No	No	No	Yes	Yes	No	No	No	No	Yes	Yes ⁵⁾	No	
CAM_ExComp On/Off		No	No	No	Yes	Yes	Yes	Yes	Yes	Yes	Yes	Yes ⁵⁾	No	
CAM_ExComp Reset/Up/Down/Direct ⁶⁾		No	No	No	Yes	Yes	Yes	Yes	Yes	Yes	Yes	Yes ⁵⁾	No	
CAM_Backlight On/Off		No	No	No	No	No	No	No	Yes	Yes	No	Yes ⁵⁾	No	
CAM_WD On/Off ⁷⁾		No	No	No	Yes	Yes	Yes	Yes	Yes	Yes	Yes	Yes ⁵⁾	No	

1) DC power is being supplied, but the camera has been turned off by a VISCA command.

2) The period from the time IFC is sent, until the Reply Packet is returned.

3) The period from the time DC power is turned on or the camera is turned on via a VISCA command, and the camera subsequently finishes the pan/tilt reset operation and stops at the Home position, until the video signal is output. Or the period from the time the CAM Power ON command is sent, until Completion is returned.

4) Yes: Only when the camera changes to BRIGHT mode from Full Auto or SHUTTER Pri mode.

5) When the menu display is updating, operation is not possible.

6) No: This is not allowed when EX-COMP is set to OFF.

7) The settings are available; however, command actions will be executed only after Wide-D is set to OFF.

8) This command is available on EVI-D90N/P only.

Effect

Command	Mode	Power Off ¹⁾	Power On			
			IFC ²⁾	Initializing ³⁾	During displaying the menu	Memory Recall
CAM_Aperture Reset/Up/Down/Direct		No	No	No	Yes ⁴⁾	No
Display info. (ON/OFF)		No	No	No	Yes ⁴⁾	No
CAM_PictureEffect OFF/Neg-Art/B&W		No	No	No	Yes ⁴⁾	No
CAM_ICR ON/OFF		No	No	No	Yes ⁴⁾	No
CAM_AutoICR ON/OFF/Threshold		No	No	No	Yes ⁴⁾	No
CAM_HR ON/OFF		No	No	No	Yes ⁴⁾	No
CAM_NR		No	No	No	Yes ⁴⁾	No

1) DC power is being supplied, but the camera has been turned off by a VISCA command.

2) The period from the time IFClear is sent, until the Reply Packet is returned.

3) The period from the time DC power is turned on or the camera is turned on via a VISCA command, and the camera subsequently finishes the pan/tilt reset operation and stops at the Home position, until the video signal is output. Or the period from the time the CAM Power ON command is sent, until Completion is returned.

4) When the menu display is updating, operation is not possible.

Pan/Tilt

Command	Mode		Power Off ¹⁾	IFC ²⁾	Initia-lizing ³⁾	Zoom (Direct)	Focus (Direct)	Power On											
	Transmit device	Power Off ¹⁾						Pan/Tilt normal status											
								Pan/tilt movement according to the command ⁴⁾	Absolute Position execution	Relative Position execution	Home execution		Reset execution		Memory Recall		During the displaying the menu	Position detection error	
Pan-tiltDrive Up/Down/Left/Right/UpLeft/UpRight/DownLeft/DownRight	Transmit device						Common	VISCA	RC	VISCA	RC	VISCA	RC	VISCA	RC	VISCA	RC		
	VISCA	No	No	Yes	Yes	Yes	Yes	No	No	VISCA	No	No	No	No	No	No	No	No	Yes ⁸⁾
Pan-tiltDrive Stop	Transmit device						Yes	Yes	Yes	VISCA	No	No	No	No	No	No	No	No	Yes
	VISCA	No	No	Yes	Yes	Yes	Yes	No	No	VISCA	No	No	No	No	No	No	No	No	Yes ⁸⁾
Pan-tiltDrive AbsolutePosition	Transmit device						Yes	Yes	Yes	VISCA	No	No	No	No	No	No	No	No	No
	VISCA	No	No	Yes	Yes	Yes	Yes	No	No	VISCA	No	No	No	No	No	No	No	No	Yes ⁵⁾
Pan-tiltDrive RelativePosition	Transmit device						Yes	Yes	Yes	VISCA	No	No	No	No	No	No	No	No	Yes
	VISCA	No	No	Yes	Yes	Yes	Yes	No	No	VISCA	No	No	No	No	No	No	No	No	Yes ⁵⁾
Pan-tiltDrive Home	Transmit device						Yes	Yes	Yes	VISCA	No	No	No	Yes	No	No	No	No	No
	RC	No	No	Yes	Yes	Yes	Yes	No	No	VISCA	No	No	No	Yes	No	No	No	No	No
Pan-tiltDrive Reset	Transmit device						Yes	Yes	Yes	VISCA	No	No	No	No	No	No	No	No	Yes
	VISCA	No	No	Yes	Yes	Yes	Yes	No	No	VISCA	No	No	No	No	No	No	No	No	Yes ⁵⁾
Pan-tiltLimitSet LimitSet	Transmit device						Yes	Yes	Yes	VISCA	No	No	No	No	No	No	No	No	No
	VISCA	No	No	Yes	Yes	Yes	Yes	No	No	VISCA	No	No	No	No	No	No	No	No	Yes ⁵⁾
Pan-tiltLimitSet LimitClear	Transmit device						Yes	Yes	Yes	VISCA	No	No	No	No	No	No	No	No	No
	VISCA	No	No	Yes	Yes	Yes	Yes	No	No	VISCA	No	No	No	No	No	No	No	No	Yes ⁵⁾
Memory Set	Transmit device						No	No	No	Common	No	No	No	No	No	No	No	No	No
	Common	No	No	No	No	No	No	No	No	Common	No	No	No	No	No	No	No	No	No
Memory Reset	Transmit device						No	No	No	Common	No	No	No	No	No	No	No	No	No
	Common	No	No	No	No	No	No	No	No	Common	No	No	No	No	No	No	No	No	No
Memory Recall	Transmit device						No ⁶⁾	No ⁷⁾	No ⁷⁾	VISCA	No	No	No	No	No	No	No	Yes	No
	VISCA	No	No	No	No	No	No ⁶⁾	No ⁷⁾	No ⁷⁾	RC	No	No	No	No	No	No	No	Yes	No
CAM_NR ⁹⁾	Transmit device						Yes	Yes	Yes	VISCA	No ¹⁰⁾	No ¹⁰⁾	No ¹⁰⁾	No ¹⁰⁾	Yes	Yes	No	No	Yes
	VISCA	No	No	Yes	Yes	Yes	Yes	No ¹⁰⁾	No ¹⁰⁾	VISCA	No ¹⁰⁾	No ¹⁰⁾	No ¹⁰⁾	Yes	Yes	No	No	Yes ⁵⁾	Yes

1) DC power is being supplied, but the camera has been turned off by a VISCA command.

2) The period from the time IF Clear is sent, until the Reply Packet is returned.

3) The period from the time DC power is turned on or the camera is turned on via a VISCA command, and the camera subsequently finishes the pan/tilt reset operation and stops at the Home position, until the video signal is output.

4) The pan/tilt operation works by Pan-tiltDrive Up/Down/Left/Right/UpLeft/UpRight/DownLeft/DownRight commands.

5) When the menu display is updating, operation is not possible.

6) Yes: while the camera operates in Tele/Wide zoom mode.

7) Yes: while the camera operates in Far/Near focus mode.

8) Yes: only for movements away from the direction where a position detection error has been recognized.

9) When CAM commands or other inquiry commands are received after the pan/tilt movement has been stopped, "Command not executable" may be returned for a maximum of 120 msec due to internal processing. In this case, please transmit the command again.

10) Yes: when pan/tilt moves at high speed.

Command List

VISCA¹⁾ RS-232C Commands

Use of RS-232C control software which has been developed based upon this command list may cause malfunction or damage to hardware and software. Sony Corporation is not liable for any such damage.

Overview of VISCA

In VISCA, the device producing the commands, for example, a computer, is called the controller, while the device receiving the commands, such as an EVI-D80N/D80P/D90N/D90P, is called the peripheral device. The EVI-D80N/D80P/D90N/D90P serves as a peripheral device in VISCA. In VISCA, up to seven peripheral devices like the EVI-D80N/D80P/D90N/D90P can be connected to one controller using communication conforming to the RS-232C standard. The parameters of RS-232C are as follows.

- Communication speed: 9,600 bps/38,400 bps
- Data bits : 8
- Start bit : 1
- Stop bit : 1
- Non parity

Flow control using XON/XOFF and RTS/CTS, etc., is not supported.

Peripheral devices are connected in a daisy chain. As shown in Fig. 1, the actual internal connection is a one-direction ring, so that messages return to the controller via the peripheral devices. The devices on the network are assigned addresses.

The address of the controller is fixed at 0. The addresses of the peripheral devices are 1, 2, 3 ... in order, starting from the one nearest the controller. The address of the peripheral device is set by sending address commands during the initialization of the network.

The VISCA devices each have a VISCA IN and VISCA OUT connector.

Set the DSR input (the DTR output of the controller) of VISCA IN to H when controlling VISCA equipment from the controller.

Fig. 1 VISCA network configuration

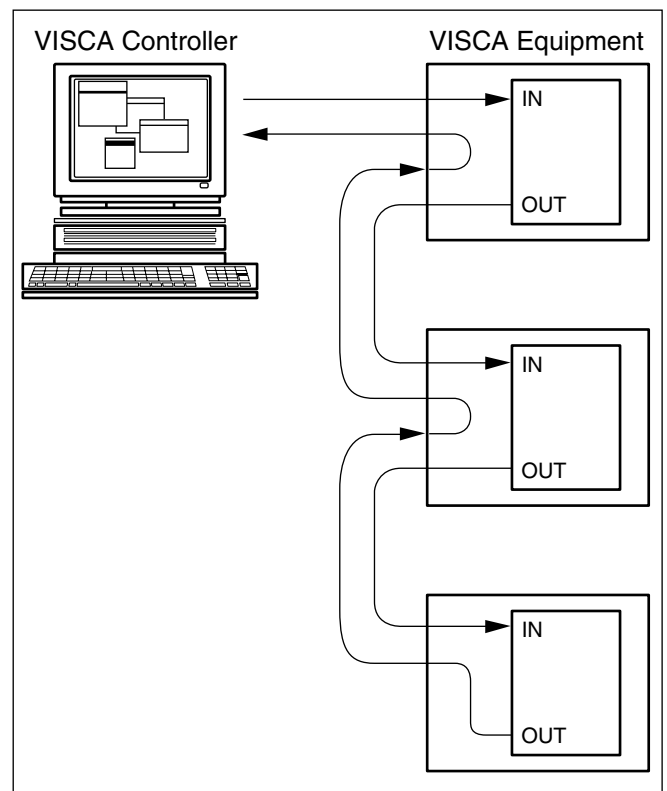

1) VISCA is a protocol which controls consumer camcorders developed by Sony. "VISCA" is a trademark of Sony Corporation.

VISCA Communication Specifications

VISCA packet structure

The basic unit of VISCA communication is called a packet (Fig. 2). The first byte of the packet is called the header and comprises the sender's and receiver's addresses. For example, the header of the packet sent to the EVI-D80N/D80P/D90N/D90P assigned address 1 from the controller (address 0) is hexadecimal 81H.

The packet sent to the EVI-D80N/D80P/D90N/D90P assigned address 2 is 82H. In the command list, as the header is 8X, input the address of the EVI-D80N/D80P/D90N/D90P at X. The header of the reply packet from the EVI-D80N/D80P/D90N/D90P assigned address 1 is 90H. The packet from the EVI-D80N/D80P/D90N/D90P assigned address 2 is A0H. Some of the commands for setting EVI-D80N/D80P/D90N/D90P units can be sent to all devices at one time (broadcast). In the case of broadcast, the header should be hexadecimal 88H. When the terminator is FFH, it signifies the end of the

packet.

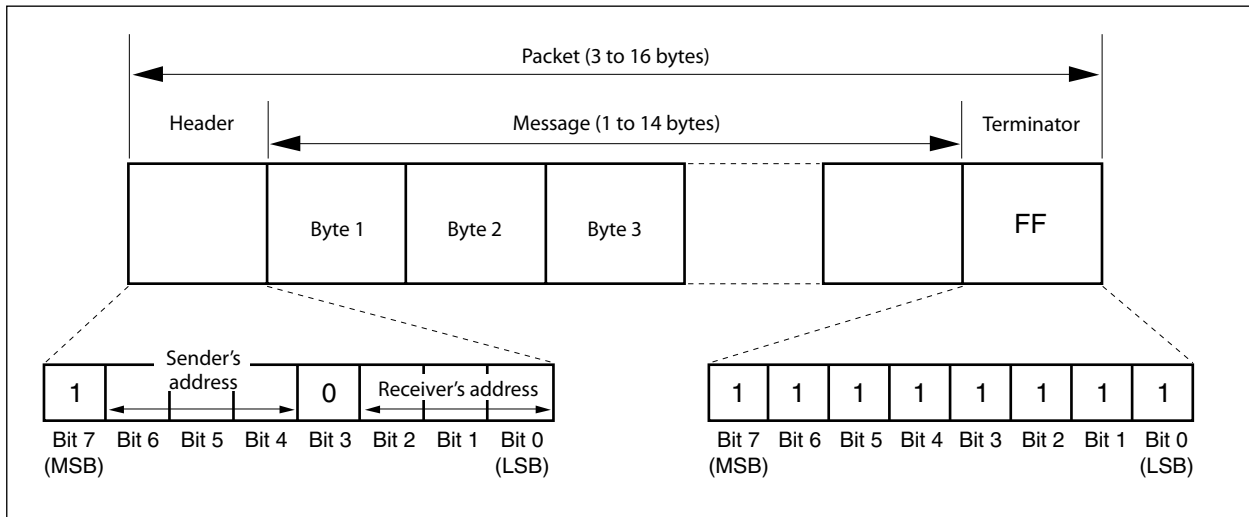

Fig. 2 Packet structure

Note

Fig. 2 shows the packet structure, while Fig. 3 shows the actual waveform. Data flow will take place with the LSB first.

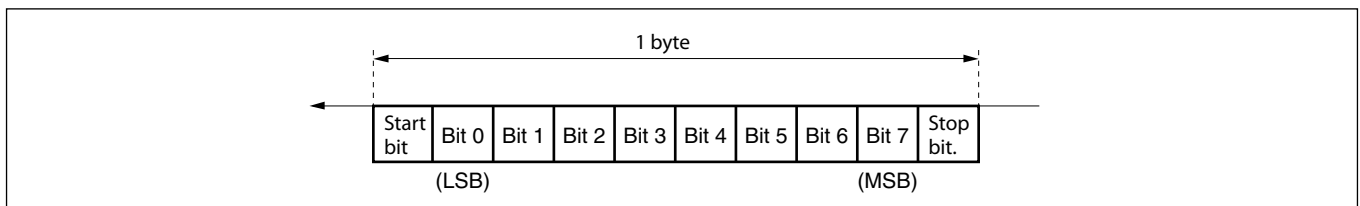
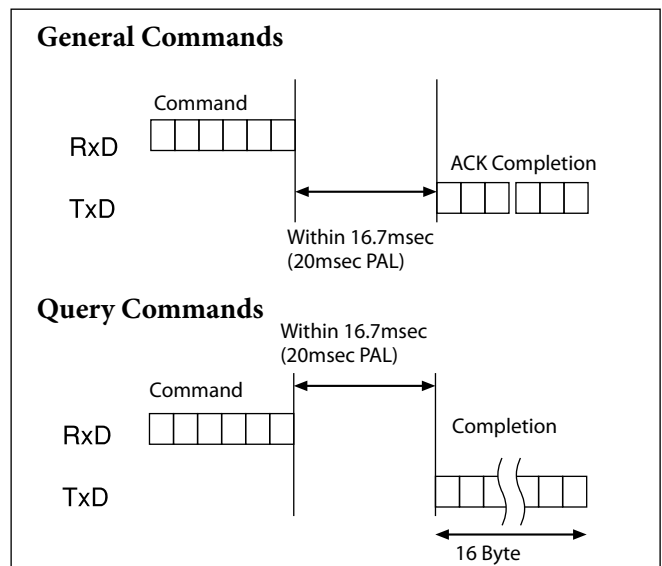

Fig. 3 Actual waveform for 1 byte.

Timing Chart

As VISCA Command processing can only be carried out one time in a Vertical cycle, it takes the maximum 1V cycle time for an ACK/Completion to be returned. If the Command ACK/Completion communication time can be cut shorter than the 1V cycle time, then every 1V cycle can receive a Command.



Command and inquiry

● Command

Sends operational commands to the EVI-D80N/D80P/D90N/D90P.

● Inquiry

Used for inquiring about the current state of the EVI-D80N/D80P/D90N/D90P.

	Command Packet	Note
Inquiry	8X QQ RR ... FF	QQ ¹⁾ = Command/Inquiry, RR ²⁾ = category code

¹⁾ QQ = 01 (Command), 09 (Inquiry)

²⁾ RR = 00 (Interface), 04 (camera 1), 06 (Pan/Tilter)

X = 1 to 7: EVI-D80N/D80P/D90N/D90P address

Responses for commands and inquiries

● ACK message

Returned by the EVI-D80N/D80P/D90N/D90P when it receives a command. No ACK message is returned for inquiries.

● Completion message

Returned by the EVI-D80N/D80P/D90N/D90P when execution of commands or inquiries is completed. In the case of inquiry commands, it will contain reply data for the inquiry after the 3rd byte of the packet. If the ACK message is omitted, the socket number will contain a 0.

	Reply Packet	Note
Ack	X0 4Y FF	Y = socket number
Completion (commands)	X0 5Y FF	Y = socket number
Completion (Inquiries)	X0 5Y ... FF	Y = socket number

X = 9 to F: EVI-D80N/D80P/D90N/D90P address + 8

● Error message

When a command or inquiry command could not be executed or failed, an error message is returned instead of the completion message.

Error Packet	Description
X0 6Y 02 FF	Syntax Error
X0 6Y 03 FF	Command buffer full
X0 6Y 04 FF	Command canceled
X0 6Y 05 FF	No socket (to be canceled)
X0 6Y 41 FF	Command not executable

X = 9 to F: EVI-D80N/D80P/D90N/D90P address + 8, Y = socket number

Socket number

When command messages are sent to the EVI-D80N/D80P/D90N/D90P, it is normal to send the next command message after waiting for the completion message or error message to return.

However to deal with advanced uses, the EVI-D80N/D80P/D90N/D90P has two buffers (memories) for commands, so that up to two commands including the commands currently being executed can be received.

When the

EVI-D80N/D80P/D90N/D90P receives commands, it notifies the sender which command buffer was used using the socket number of the ACK message.

As the completion message or error message also has a socket number, it indicates which command has ended. Even when two command buffers are being used at any one time, an EVI-D80N/D80P/D90N/D90P management command and some inquiry messages can be executed.

The ACK message is not returned for these commands and inquiries, and only the completion message of socket number 0 is returned.

The following command use two sockets during execution of each command that is sent. The EVI-D80N/D80P/D90N/D90P cannot receive other requests during execution of these commands. In addition, these commands cannot be executed during operation of other commands.

- SYS_Menu

Command execution cancel

To cancel a command which has already been sent, send the Cancel command as the next command. To cancel one of any two commands which have been sent, use the cancel message.

	Cancel Packet	Note
Cancel	8X 2Y FF	Y = socket number

X = 1 to 7: EVI-D80N/D80P/D90N/D90P address, Y = socket number

The Command canceled error message will be returned for this command, but this is not a fault. It indicates that the command has been canceled.

VISCA Device Setting Command

Before starting control of the EVI-D80N/D80P/D90N/D90P, be sure to send the Address command and the IF_Clear command using the broadcast function.

For VISCA network administration

● Address Set

Sets an address of a peripheral device. Use when initializing the network, and receiving the following network change message.

	Command	Reply
Address Set	88 30 01 FF	88 30 0w FF
w = 2 to 7: EVI-D80N/D80P/D90N/D90P address + 8		

● Network Change

Sent from the peripheral device to the controller when a device is removed from or added to the network. The address must be re-set when this message is received.

	Received Packet
Network Change	X0 38 FF
X = 9 to F: EVI-D80N/D80P/D90N/D90P address + 8	

VISCA interface command

● IF_Clear

Clears the command buffers in the EVI-D80N/D80P/D90N/D90P and cancels the command currently being executed.

	Command Packet	Reply Packet	Note
IF_Clear	8X 01 00 01FF	Y0 50 FF	
IF_Clear (broadcast)	88 01 00 01 FF	88 01 00 01 FF	
X = 1 to 7: EVI-D80N/D80P/D90N/D90P address			
Y = 9 to F: EVI-D80N/D80P/D90N/D90P address +8			

VISCA interface and inquiry

● CAM_VersionInq

Returns information on the VISCA interface.

Inquiry	Inquiry Packet	Reply Packet	Description
CAM_VersionInq	8X 09 00 02 FF	Y0 50 GG GG HH HH JJ JJ KK FF	GGGG = Vender ID (0001: Sony) HHHH = Model ID 050C: EVI-D80N/P 050D: EVI-D90N/P JJJJ = ROM revision KK = Maximum socket # (02)

X = 1 to 7: EVI-D80N/D80P/D90N/D90P address (For inquiry packet)

X = 9 to F: EVI-D80N/D80P/D90N/D90P address +8 (For reply packet)

Pin assignment

VISCA IN connector (mini-DIN 8-pin, female)

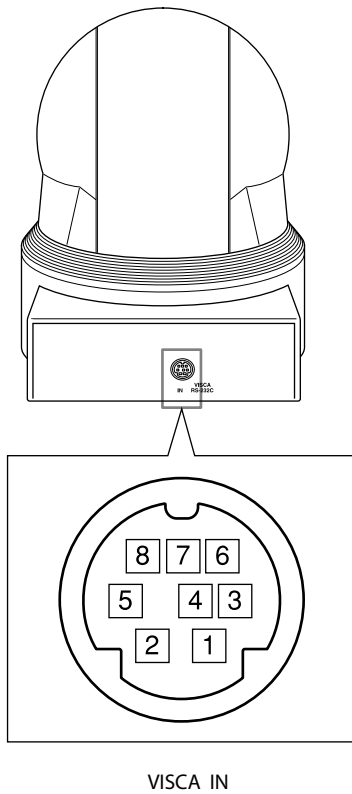

No	Pins
1	DTR IN*
2	DSR IN*
3	TXD IN
4	GND
5	RXD IN
6	GND
7	IR OUT**
8	Not used

* The "IN" in the function names for pins 1 and 2 ("DTR IN" and "DSR IN") are in reference to being within the VISCA IN connector. For details on signal direction, see the diagrams to the right.

** You can change ON/OFF of IR OUT of pins 7 using the BOTTOM switch (see page 6).

- EVI-D80N/D80P/ D90N/D90P

1. DTR	→	2. RXD
2. DSR	→	3. TXD
3. TXD	→	4. DTR
4. GND	→	5. GND
5. RXD	→	6. DSR
6. GND	→	7. RTS
7. IR OUT	→	8. CTS
8. Not used	→	9. RI

Windows D-sub 9 pin
- EVI-D80N/D80P/ D90N/D90P

1. DTR	→	1. DTR
2. DSR	→	2. DSR
3. TXD	→	3. TXD
4. GND	→	4. GND
5. RXD	→	5. RXD
6. GND	→	6. GND
7. IR OUT	→	7. OPEN
8. Not used	→	8. OPEN

EVI Camera or Mini DIN 8 pin serial
- EVI-D80N/D80P/ D90N/D90P

1. DTR	→	1. FG
2. DSR	→	2. TXD
3. TXD	→	3. RXD
4. GND	→	4. RTS
5. RXD	→	5. CTS
6. GND	→	6. DSR
7. IR OUT	→	7. GND
8. Not used	→	20. DTR

Windows D-sub 25 pin

Using the VISCA RS-422 connector pin assignments

The VISCA RS-422 connector pin assignments

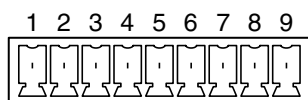

VISCA RS-422

Pin No.	Function
1	TXD IN+
2	TXD IN-
3	RXD IN+
4	RXD IN-
5	GND
6	TXD OUT+
7	TXD OUT-
8	RXD OUT+
9	RXD OUT-

Note

- In order to stabilize the voltage level of the signal, connect both ends to GND.
- Do not make a VISCA RS-232C connection when there is already an existing VISCA RS-422 connection.

Using the VISCA RS-422 connector plug

- 1 Insert a wire (AW G Nos. 28 to 18) into the desired wire opening on the supplied VISCA RS-422 connector plug, and tighten the screw for that wire using a flat-head screwdriver.

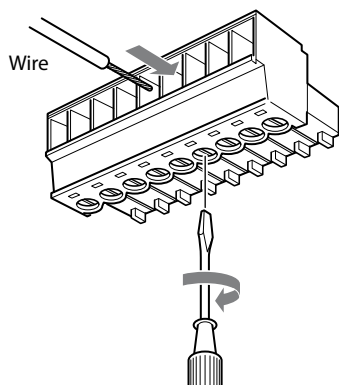

Flat-head screwdriver

- 2 Insert the VISCA RS-422 connector plug into the VISCA RS-422 connector on the rear of the camera.

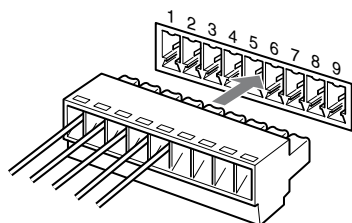

VISCA Command/ACK Protocol

Command	Command Message	Reply Message	Comments
General Command	81 01 04 38 02 FF (Example)	90 41 FF (ACK)+90 51 FF (Completion) 90 42 FF 90 52 FF	Returns ACK when a command has been accepted, and Completion when a command has been executed.
	81 01 04 38 FF (Example)	90 60 02 FF (Syntax Error)	Accepted a command which is not supported or a command lacking parameters.
	81 01 04 38 02 FF (Example)	90 60 03 FF (Command Buffer Full)	There are two commands currently being executed, and the command could not be accepted.
	81 01 04 08 02 FF (Example)	90 61 41 FF (Command Not Executable) 90 62 41FF	Could not execute the command in the current mode.
Inquiry Command	81 09 04 38 FF (Example)	90 50 02 FF (Completion)	ACK is not returned for the inquiry command.
	81 09 05 38 FF (Example)	90 60 02 FF (Syntax Error)	Accepted an incompatible command.
Address Set	88 30 01 FF	88 30 0w FF	w: Returned the device address to +1. (2 to 8)
IF_Clear(Broadcast)	88 01 00 01 FF	88 01 00 01 FF	Returned the same command.
IF_Clear (For x)	8x 01 00 01 FF	z0 50 FF (Completion)	ACK is not returned for this command.
Command Cancel	8x 2y FF (y:Socket No.)	z0 6y 04 FF (Command Canceled)	Returned when the command of the socket specified is canceled. Completion for the command canceled is not returned.
		z0 6y 05 FF (No Socket)	Returned when the command of the specified socket has already been completed or when the socket number specified is wrong.

z = Device address + 8

VISCA Camera-Issued Messages

ACK/Completion Messages

	Command Messages	Comments
ACK	z0 4y FF (y:Socket No.)	Returned when the command is accepted.
Completion	z0 5y FF (y:Socket No.)	Returned when the command has been executed.

z = Device address + 8

Error Messages

	Command Messages	Comments
Syntax Error	z0 60 02 FF	Returned when the command format is different or when a command with illegal command parameters is accepted.
Command Buffer Full	z0 60 03 FF	Indicates that two sockets are already being used (executing two commands) and the command could not be accepted when received.
Command Canceled	z0 6y 04 FF (y:Socket No.)	Returned when a command which is being executed in a socket specified by the cancel command is canceled. The completion message for the command is not returned.
No Socket	z0 6y 05 FF (y:Socket No.)	Returned when no command is executed in a socket specified by the cancel command, or when an invalid socket number is specified.
Command Not Executable	z0 6y 41 FF (y:Execution command Socket No. Inquiry command:0)	Returned when a command cannot be executed due to current conditions. For example, when commands controlling the focus manually are received during auto focus.

z = Device address + 8

Network Change Message

	Command Message	Comments
Network Change	z0 38 FF	Issued when power is being routed to the camera, or when the VISCA device is connected to or disconnected from the VISCA OUT connector.

z = Device address + 8

EVI-D80N/D80P/D90N/D90P Commands

EVI-D80N/D80P/D90N/D90P Command List (1/3)

Command Set	Command	Command Packet	Comments	
AddressSet	Broadcast	88 30 01 FF	Address setting	
IF_Clear	Broadcast	88 01 00 01 FF	I/F Clear	
CommandCancel		8x 2p FF	p: Socket No. (=1 or 2)	
CAM_Power	On	8x 01 04 00 02 FF	Power ON/OFF	
	Off	8x 01 04 00 03 FF		
CAM_Zoom	Stop	8x 01 04 07 00 FF	p=0 (Low) to 7 (High) pqrs: Zoom Position	
	Tele (Standard)	8x 01 04 07 02 FF		
	Wide (Standard)	8x 01 04 07 03 FF		
	Tele (Variable)	8x 01 04 07 2p FF		
	Wide (Variable)	8x 01 04 07 3p FF		
	Direct	8x 01 04 47 0p 0q 0r 0s FF		
CAM_DZoom	On	8x 01 04 06 02 FF	Digital zoom ON/OFF	
	Off	8x 01 04 06 03 FF		
CAM_Focus	Stop	8x 01 04 08 00 FF	p=0 (Low) to 7 (High) pqrs: Focus Position AF ON/OFF	
	Far (Standard)	8x 01 04 08 02 FF		
	Near (Standard)	8x 01 04 08 03 FF		
	Far (Variable)	8x 01 04 08 2p FF		
	Near (Variable)	8x 01 04 08 3p FF		
	Direct	8x 01 04 48 0p 0q 0r 0s FF		
	Auto Focus	8x 01 04 38 02 FF		
	Manual Focus	8x 01 04 38 03 FF		
	Auto/Manual	8x 01 04 38 10 FF		
	One Push Trigger	8x 01 04 18 01 FF		One Push AF Trigger
	Infinity	8x 01 04 18 02 FF		Forced infinity
	Near Limit	8x 01 04 28 0p 0q 0r 0s FF		pqrs: Focus Near Limit Position
AF Sensitivity	Normal	8x 01 04 58 02 FF	AF Sensitivity High/Low	
	Low	8x 01 04 58 03 FF		
CAM_AFMode	Normal AF	8x 01 04 57 00 FF	AF Movement Mode pq: Movement Time, rs: Interval	
	Interval AF	8x 01 04 57 01 FF		
	Zoom Trigger AF	8x 01 04 57 02 FF		
	Active/Interval Time	8x 01 04 27 0p 0q 0r 0s FF		
CAM_IRCorrection	Standard	8x 01 04 11 00 FF	FOCUS IR compensation data switching	
	IR Light	8x 01 04 11 01 FF		
CAM_ZoomFocus	Direct	8x 01 04 47 0p 0q 0r 0s 0t 0u 0v 0w FF	pqrs: Zoom Position tuvw: Focus Position	
CAM_WB	Auto	8x 01 04 35 00 FF	Normal Auto	
	Indoor	8x 01 04 35 01 FF	Indoor mode	
	Outdoor	8x 01 04 35 02 FF	Outdoor mode	
	One Push WB	8x 01 04 35 03 FF	One Push WB mode	
	Manual	8x 01 04 35 05 FF	Manual Control mode	
	One Push Trigger ^{1) 6)}	8x 01 04 10 05 FF	One Push WB Trigger	
CAM_RGain	Reset	8x 01 04 03 00 FF	Manual Control of R Gain pq: R Gain	
	Up	8x 01 04 03 02 FF		
	Down	8x 01 04 03 03 FF		
	Direct	8x 01 04 43 00 00 0p 0q FF		
CAM_BGain	Reset	8x 01 04 04 00 FF	Manual Control of B Gain pq: B Gain	
	Up	8x 01 04 04 02 FF		
	Down	8x 01 04 04 03 FF		
	Direct	8x 01 04 44 00 00 0p 0q FF		

EVI-D80N/D80P/D90N/D90P Command List (2/3)

Command Set	Command	Command Packet	Comments
CAM_AE	Full Auto	8x 01 04 39 00 FF	Automatic Exposure mode
	Manual	8x 01 04 39 03 FF	Manual Control mode
	Shutter Priority	8x 01 04 39 0A FF	Shutter Priority Automatic Exposure mode
	Iris Priority	8x 01 04 39 0B FF	Iris Priority Automatic Exposure mode
	Bright ²⁾	8x 01 04 39 0D FF	Bright Mode (Manual control)
CAM_SlowShutter	Auto	8x 01 04 5A 02 FF	Auto Slow Shutter ON/OFF
	Manual	8x 01 04 5A 03 FF	
CAM_Shutter	Reset	8x 01 04 0A 00 FF	Shutter Setting
	Up	8x 01 04 0A 02 FF	
	Down	8x 01 04 0A 03 FF	
	Direct	8x 01 04 4A 00 00 0p 0q FF	pq: Shutter Position
CAM_Iris	Reset	8x 01 04 0B 00 FF	Iris Setting
	Up	8x 01 04 0B 02 FF	
	Down	8x 01 04 0B 03 FF	
	Direct	8x 01 04 4B 00 00 0p 0q FF	pq: Iris Position
CAM_Gain	Reset	8x 01 04 0C 00 FF	Gain Setting
	Up	8x 01 04 0C 02 FF	
	Down	8x 01 04 0C 03 FF	
	Direct	8x 01 04 4C 00 00 0p 0q FF	pq: Gain Position
	AE Gain Limit	8x 01 04 2C 0p FF	p: Gain Position (4-F)
CAM_Bright	Up	8x 01 04 0D 02 FF	Bright Setting
	Down	8x 01 04 0D 03 FF	
	Direct	8x 01 04 4D 00 00 0p 0q FF	pq: Bright Position
CAM_ExpComp	On	8x 01 04 3E 02 FF	Exposure Compensation ON/OFF
	Off	8x 01 04 3E 03 FF	
	Reset	8x 01 04 0E 00 FF	Exposure Compensation Amount Setting
	Up	8x 01 04 0E 02 FF	
	Down	8x 01 04 0E 03 FF	
	Direct	8x 01 04 4E 00 00 0p 0q FF	
CAM_BackLight	On	8x 01 04 33 02 FF	Back Light Compensation ON/OFF
	Off	8x 01 04 33 03 FF	
CAM_WD ⁵⁾	On	8x 01 04 3D 02 FF	Wide-D ON/OFF
	Off	8x 01 04 3D 03 FF	
	Auto On Off	8x 01 04 3D 00 FF	Wide dynamic ON/OFF auto switching
	On (Ratio Fix)	8x 01 04 3D 01 FF	Wide dynamic ON (Fixed exposure ratio mode)
	On (Histogram)	8x 01 04 3D 04 FF	Wide dynamic ON (Histogram mode)
	Refresh	8x 01 04 10 0D FF	Wide dynamic Refresh
	Set Parameter	8x 01 04 2D 0p 0q 0r 0s 0t 0u 00 00 FF	p: Screen display (0: Combined image, 2: Long-time, 3: Short-time) q: Detection sensitivity (0: L 1: M 2: H) r: Blocked-up shadow correction level (0: L 1: M 2: H 3: S) s: Blown-out highlight correction level (0: L 1: M 2: H) tu: Exposure ratio of short exposure (x1 to x64)
CAM_Aperture	Reset	8x 01 04 02 00 FF	Aperture Control
	Up	8x 01 04 02 02 FF	
	Down	8x 01 04 02 03 FF	
	Direct	8x 01 04 42 00 00 0p 0q FF	pq: Aperture Gain
CAM_HR	On	8x 01 04 52 02 FF	High-Resolution Mode ON/OFF
	Off	8x 01 04 52 03 FF	
CAM_NR		8x 01 04 53 0p FF	p: NR Setting (0: OFF, level 1 to 5)

EVI-D80N/D80P/D90N/D90P Command List (3/3)

Command Set	Command	Command Packet	Comments
CAM_PictureEffect	Off	8x 01 04 63 00 FF	Picture Effect Setting
	Neg.Art	8x 01 04 63 02 FF	
	B&W	8x 01 04 63 04 FF	
CAM_ICR ⁵⁾	On	8x 01 04 01 02 FF	Infrared Mode ON/OFF
	Off	8x 01 04 01 03 FF	
CAM_AutoICR ⁵⁾	On	8x 01 04 51 02 FF	Auto dark-field mode On/Off
	Off	8x 01 04 51 03 FF	
	Threshold	8x 01 04 21 00 00 0p 0q FF	
CAM_Memory	Reset ³⁾⁶⁾	8x 01 04 3F 00 0p FF	p: Memory Number (=0 to 5)
	Set ³⁾⁶⁾	8x 01 04 3F 01 0p FF	Corresponds to 1 to 6 on the Remote Commander.
	Recall ³⁾⁴⁾	8x 01 04 3F 02 0p FF	
CAM_IDWrite		8x 01 04 22 0p 0q 0r 0s FF	pqrs: Camera ID (=0000 to FFFF)
SYS_Menu	Off	8x 01 06 06 03 FF	Turns off the menu screen.
IR_Receive	On	8x 01 06 08 02 FF	IR(remote commander) receive ON/OFF
	Off	8x 01 06 08 03 FF	
	On/Off	8x 01 06 08 10 FF	
IR_ReceiveReturn	On	8x 01 7D 01 03 00 00 FF	IR (remote commander) receive message via the VISCA communication ON/OFF
	Off	8x 01 7D 01 13 00 00 FF	For contents of messages, see page 33.
Information Display	On	8x 01 7E 01 18 02 FF	ON/OFF of the Operation status display of One Push
	Off	8x 01 7E 01 18 03 FF	Trigger of CAM_Memory and CAM_WB
Pan-tiltDrive	Up ³⁾	8x 01 06 01 VV WW 03 01 FF	VV: Pan speed 01 to 18
	Down ³⁾	8x 01 06 01 VV WW 03 02 FF	WW: Tilt Speed 01 to 17
	Left ³⁾	8x 01 06 01 VV WW 01 03 FF	YYYY: Pan Position E1E5 to 1E1B (center 0000)
	Right ³⁾	8x 01 06 01 VV WW 02 03 FF	ZZZZ: Tilt Position FC75 to 0FF0 (IMAGE FLIP: OFF)
	UpLeft ³⁾	8x 01 06 01 VV WW 01 01 FF	(center 0000)
	UpRight ³⁾	8x 01 06 01 VV WW 02 01 FF	Tilt Position F010 to 038B (IMAGE FLIP: ON)
	DownLeft ³⁾	8x 01 06 01 VV WW 01 02 FF	(center 0000)
	DownRight ³⁾	8x 01 06 01 VV WW 02 02 FF	See page 42
	Stop ³⁾	8x 01 06 01 VV WW 03 03 FF	
	AbsolutePosition	8x 01 06 02 VV WW 0Y 0Y 0Y 0Y 0Z 0Z 0Z 0Z FF	
	RelativePosition	8x 01 06 03 VV WW 0Y 0Y 0Y 0Y 0Z 0Z 0Z 0Z FF	
	Home	8x 01 06 04 FF	
	Reset	8x 01 06 05 FF	
Pan-tiltLimitSet	LimitSet	8x 01 06 07 00 0W 0Y 0Y 0Y 0Y 0Z 0Z 0Z 0Z FF	W: 1 UpRight YYYY: Pan Limit Position 0001 to 1E1B
	LimitClear	8x 01 06 07 01 0W 07 0F 0F 0F 07 0F 0F 0F FF	ZZZZ: Tilt Limit Position 0001 to 0FF0 (IMAGE FLIP: OFF) Tilt Limit Position 0001 to 038B (IMAGE FLIP: ON) W: 0 DownLeft YYYY: Pan Limit Position E1E5 to FFFF ZZZZ: Tilt Limit Position FC75 to FFFF (IMAGE FLIP: OFF) Tilt Limit Position F010 to FFFF (IMAGE FLIP: ON)

- 1) After an ACK to a One Push White Balance Trigger is sent until the operation is completed, "Not Executable" is sent as a reply when any other commands are received.
- 2) Bright can be set only in Full Auto mode or Shutter Priority mode.
- 3) When the menu is displayed, this operation is ignored.
- 4) When other commands are received after a Completion notification for the Recall command is sent, "Command not executable" may be returned for a maximum of 240 msec due to internal processing. In this case, please transmit the command again.
- 5) The command is available on EVI-D90N/P only.
- 6) If Information Display is set to ON, the next command action may be delayed due to Operation status display internal processing after these commands are executed.

EVI-D80N/D80P/D90N/D90P Inquiry Command List (1/2)

Inquiry Command	Command Packet	Inquiry Packet	Comments
CAM_PowerInq	8x 09 04 00 FF	y0 50 02 FF	On
		y0 50 03 FF	Off
CAM_ZoomPosInq	8x 09 04 47 FF	y0 50 0p 0q 0r 0s FF	pqrs: Zoom Position
CAM_DZoomModeInq	8x 09 04 06 FF	y0 50 02 FF	D-Zoom On
		y0 50 03 FF	D-Zoom Off
CAM_FocusModeInq	8x 09 04 38 FF	y0 50 02 FF	Auto Focus
		y0 50 03 FF	Manual Focus
CAM_FocusPosInq	8x 09 04 48 FF	y0 50 0p 0q 0r 0s FF	pqrs: Focus Position
CAM_FocusNearLimitInq	8x 09 04 28 FF	y0 50 0p 0q 0r 0s FF	pqrs: Focus Near Limit Position
CAM_AFSensitivityInq	8x 09 04 58 FF	y0 50 02 FF	AF Sensitivity Normal
		y0 50 03 FF	AF Sensitivity Low
CAM_AFModeInq	8x 09 04 57 FF	y0 50 00 FF	Normal AF
		y0 50 01 FF	Interval AF
		y0 50 02 FF	Zoom Trigger AF
CAM_AFTimeSettingInq	8x 09 04 27 FF	y0 50 0p 0q 0r 0s FF	pq: Movement Time, rs: Interval
CAM_IRCorrectionInq	8x 09 04 11 FF	y0 50 00 FF	Standard
		y0 50 01 FF	IR Light
CAM_WBModeInq	8x 09 04 35 FF	y0 50 00 FF	Auto
		y0 50 01 FF	In Door
		y0 50 02 FF	Out Door
		y0 50 03 FF	One Push WB
		y0 50 05 FF	Manual
CAM_RGainInq	8x 09 04 43 FF	y0 50 00 00 0p 0q FF	pq: R Gain
CAM_BGainInq	8x 09 04 44 FF	y0 50 00 00 0p 0q FF	pq: B Gain
CAM_AEModeInq	8x 09 04 39 FF	y0 50 00 FF	Full Auto
		y0 50 03 FF	Manual
		y0 50 0A FF	Shutter Priority
		y0 50 0B FF	Iris Priority
		y0 50 0D FF	Bright
CAM_SlowShutterModeInq	8x 09 04 5A FF	y0 50 02 FF	Auto
		y0 50 03 FF	Manual
CAM_ShutterPosInq	8x 09 04 4A FF	y0 50 00 00 0p 0q FF	pq: Shutter Position
CAM_IrisPosInq	8x 09 04 4B FF	y0 50 00 00 0p 0q FF	pq: Iris Position
CAM_GainPosInq	8x 09 04 4C FF	y0 50 00 00 0p 0q FF	pq: Gain Position
CAM_AEGainLimitInq	8x 09 04 2C FF	y0 50 0p FF	p: Gain Limit
CAM_BrightPosInq	8x 09 04 4D FF	y0 50 00 00 0p 0q FF	pq: Bright Position
CAM_ExpCompModeInq	8x 09 04 3E FF	y0 50 02 FF	On
		y0 50 03 FF	Off
CAM_ExpCompPosInq	8x 09 04 4E FF	y0 50 00 00 0p 0q FF	pq: ExpComp Position
CAM_BackLightModeInq	8x 09 04 33 FF	y0 50 02 FF	On
		y0 50 03 FF	Off
CAM_WDModeInq ¹⁾	8x 09 04 3D FF	y0 50 02 FF	On
		y0 50 03 FF	Off
		y0 50 00 FF	Auto On Off
		y0 50 01 FF	On (Ratio Fix)
		y0 50 04 FF	On (Histogram mode)

EVI-D80N/D80P/D90N/D90P Inquiry Command List (2/2)

Inquiry Command	Command Packet	Inquiry Packet	Comments
CAM_WDParameterInq ¹⁾	8x 09 04 2D FF	y0 50 0p 0q 0r 0s 0t 0u 00 00 FF	p: Screen display q: Detection sensitivity r: Blocked-up shadow correction level s: Blown-out highlight correction level tu: Exposure ratio of short exposure
CAM_ApertureInq	8x 09 04 42 FF	y0 50 00 00 0p 0q FF	pq: Aperture Gain
CAM_HRModeInq	8x 09 04 52 FF	y0 50 02 FF	On
		y0 50 03 FF	Off
CAM_NRInq	8x 09 04 53 FF	y0 50 0p FF	p: NR level
CAM_PictureEffectModeInq	8x 09 04 63 FF	y0 50 00 FF	Off
		y0 50 02 FF	Neg.Art
		y0 50 04 FF	B&W
CAM_ICRModeInq ¹⁾	8x 09 04 01 FF	y0 50 02 FF	On
		y0 50 03 FF	Off
CAM_AutoICRModeInq ¹⁾	8x 09 04 51 FF	y0 50 02 FF	On
		y0 50 03 FF	Off
CAM_AutoICRThresholdInq ¹⁾	8x 09 04 21 FF	y0 50 00 00 0p 0q FF	pq: ICR ON → OFF Threshold Level
CAM_IDInq	8x 09 04 22 FF	y0 50 0p 0q 0r 0s FF	pqrs: Camera ID
CAM_VersionInq	8x 09 00 02 FF	y0 50 00 01 mn pq rs tu vw FF	mnpq: Model Code (D80:050C/D90:050D) rstu: ROM version vw: Socket Number (=02) See page 23.
Information Display	8x 09 7E 01 18 FF	y0 50 02 FF	On
		y0 50 03 FF	Off
IR_Receive	8x 09 06 08 FF	y0 50 02 FF	On
		y0 50 03 FF	Off
IR_ReceiveReturn		y0 07 7D 01 04 00 FF	Power ON/OFF
		y0 07 7D 01 04 07 FF	Zoom tele/wide
		y0 07 7D 01 04 38 FF	AF On/Off
		y0 07 7D 01 04 33 FF	CAM_Backlight
		y0 07 7D 01 04 3F FF	CAM_Memory
		y0 07 7D 01 06 01 FF	Pan_tiltDrive
IR_ConditionInq	8x 09 06 34 FF	y0 50 00 FF	Stable reception from the IR Remote Commander
		y0 50 01 FF	Unstable reception from the IR Remote Commander
		y0 50 02 FF	Impossible to detect the infrared signals from the Remote Commander because the camera is turned on by the Remote Commander.
Pan-tiltMaxSpeedInq	8x 09 06 11 FF	y0 50 ww zz FF	ww = Pan Max Speed xx = Tilt Max Speed
Pan-tiltPosInq ²⁾	8x 09 06 12 FF	y0 50 0w 0w 0w 0w 0z 0z 0z 0z FF	wwww = Pan Position zzzz = Tilt Position Speed See page 42.
Pan-tiltModeInq	8x 09 06 10 FF	y0 50 pq rs FF	pqrs: Pan-tilt Status See page 42.

1) The command is available on EVI-D90N/P only.

2) If a Pan-tiltPosInq command is received after Pan-tiltDrive Reset, the pan/tilt position may be different for 1-2 addresses.

EVI-D80N/D80P/D90N/D90P Block Inquiry Command List

Lens Control System Inquiry Commands Command Packet 8x 09 7E 7E 00 FF

Byte	Bit	Comments	Byte	Bit	Comments	Byte	Bit	Comments			
0	7	Destination Address	6	7	0	12	7	0			
	6			0	6		0				
	5			0	5		0				
	4			0	4		0				
	3	Source Address		3	Focus Near Limit (H)		3	0			
	2			2			0				
	1			1			0				
0	0		0								
1	7	0 Completion Message (50h)	7	7	0		13	7	0		
	6	1		6	0			6	0		
	5	0		5	0			5	0		
	4	1		4	0			4	0		
	3	0		Focus Near Limit (L)	3			Focus Near Limit (L)	4	0	
	2	0			3	0					
	1	0			2	0					
	0	0			1	0					
2	7	0	8	7	0	14		7	0		
	6	0		6	0			6	0		
	5	0		5	0			5	0		
	4	0		4	0			4	0		
	3	Zoom Position (HH)		Focus Position (HH)	3			Focus Position (HH)	3	0	
2	2		0								
1	1		0								
0	0	0	0								
3	7	0	9		7		0		15	7	1 Terminator (FFh)
	6	0		6	0		6	1			
	5	0		5	0		5	1			
	4	0		4	0		4	1			
	3	Zoom Position (HL)		Focus Position (HL)	3		Focus Position (HL)	3		1	
	2				2	1					
1	1		1								
0	0	0	1								
4	7	0	10		7	0		15		6	1
	6	0			6	0				5	1
	5	0		5	0	4	1				
	4	0		4	0	3	1				
	3	Zoom Position (LH)		Focus Position (LH)	3	Focus Position (LH)	2			1	
2	2		1								
1	1		1								
0	0	0	1								
5	7	0	11		7		0		15	7	1
	6	0		6	0	6	1				
	5	0		5	0	5	1				
	4	0		4	0	4	1				
	3	Zoom Position (LL)		Focus Position (LL)	3	Focus Position (LL)	3			1	
2	2		1								
1	1		1								
0	0	0	1								

Lens Control System Inquiry Commands Command Packet 8x 09 7E 7E 01 FF

Byte	Bit	Comments
0	7	Destination Address
	6	
	5	
	4	
	3	Source Address
	2	
	1	
	0	
1	7	0 Completion Message (50h)
	6	1
	5	0
	4	1
	3	0
	2	0
	1	0
	0	0
2	7	0
	6	0
	5	0
	4	0
	3	R Gain (H)
	2	
	1	
	0	
3	7	0
	6	0
	5	0
	4	0
	3	R Gain (L)
	2	
	1	
	0	
4	7	0
	6	0
	5	0
	4	0
	3	B Gain (H)
	2	
	1	
	0	
5	7	0
	6	0
	5	0
	4	0
	3	B Gain (L)
	2	
	1	
	0	

Byte	Bit	Comments
6	7	0
	6	0
	5	0
	4	0
	3	WB Mode
	2	
	1	
	0	
7	7	0
	6	0
	5	0
	4	0
	3	Aperture Gain
	2	
	1	
	0	
8	7	0
	6	0
	5	0
	4	Exposure Mode
	3	
	2	
	1	
	0	
9	7	0
	6	0
	5	High-Resolution 1: On 0: Off
	4	Wide-D (1: Other than Off, 0: Off)
	3	0
	2	Back Light 1:On 0:Off
	1	Exposure Comp. 1:On 0:Off
	0	Slow Shutter 1:Auto 0:Manual
10	7	0
	6	0
	5	0
	4	Shutter Position
	3	
	2	
	1	
	0	
11	7	0
	6	0
	5	0
	4	Iris Position
	3	
	2	
	1	
	0	

Byte	Bit	Comments
12	7	0
	6	0
	5	0
	4	0
	3	Gain Position
	2	
	1	
	0	
13	7	0
	6	0
	5	0
	4	Bright Position
	3	
	2	
	1	
	0	
14	7	0
	6	0
	5	0
	4	0
	3	Exposure Comp. Position
	2	
	1	
	0	
15	7	1 Terminator (FFh)
	6	1
	5	1
	4	1
	3	1
	2	1
	1	1
	0	1

Other Inquiry Commands Command Packet 8x 09 7E 7E 02 FF

Byte	Bit	Comments
0	7	Destination Address
	6	
	5	
	4	
	3	Source Address
	2	
	1	
	0	
1	7	0 Completion Message (50h)
	6	1
	5	0
	4	1
	3	0
	2	0
	1	0
	0	0
2	7	0
	6	0
	5	0
	4	0
	3	0
	2	Auto ICR 1: On 0: Off
	1	0
	0	Power 1: On 0: Off
3	7	0
	6	Stabilizer (1: On, 0: Off)
	5	0
	4	ICR 1: On 0: Off
	3	0
	2	0
	1	0
	0	0
4	7	0
	6	0
	5	0
	4	Inconsistent
	3	Inconsistent
	2	Inconsistent
	1	0
	0	0
5	7	0
	6	0
	5	0
	4	0
	3	Picture Effect Mode
	2	
1		
0		

Byte	Bit	Comments
6	7	0
	6	0
	5	0
	4	0
	3	0
	2	0
	1	0
	0	0
7	7	0
	6	0
	5	0
	4	0
	3	0
	2	0
	1	0
	0	0
8	7	0
	6	0
	5	0
	4	0
	3	Camera ID (HH)
	2	
	1	
	0	
9	7	0
	6	0
	5	0
	4	0
	3	Camera ID (HL)
	2	
	1	
	0	
10	7	0
	6	0
	5	0
	4	0
	3	Camera ID (LH)
	2	
	1	
	0	
11	7	0
	6	0
	5	0
	4	0
	3	Camera ID (LL)
	2	
	1	
	0	

Byte	Bit	Comments
12	7	0
	6	0
	5	Inconsistent
	4	Memory 1: Provided 0: Not provided
	3	Inconsistent
	2	ICR 1: Provided 0: Not provided
	1	Stabilizer (1: Provided, 0: Not provided)
	0	System 1:PAL 0:NTSC
13	7	0
	6	0
	5	0
	4	0
	3	Inconsistent
	2	
	1	
	0	
14	7	0
	6	0
	5	Inconsistent
	4	
	3	
	2	
	1	0
	0	0
15	7	1 Terminator (FFh)
	6	1
	5	1
	4	1
	3	1
	2	1
	1	1
	0	1

Enlargement Function1 Query Command..... Command Packet 8x 09 7E 7E 03 FF

Byte	Bit	Comments
0	7	Destination Address
	6	
	5	
	4	
	3	Source Address
	2	
	1	
	0	
1	7	0 Completion Message (50h)
	6	1
	5	0
	4	1
	3	0
	2	0
	1	0
	0	0
2	7	0
	6	0
	5	0
	4	0
	3	0
	2	0
	1	0
	0	0
3	7	0
	6	0
	5	0
	4	0
	3	0
	2	0
	1	0
	0	0
4	7	0
	6	0
	5	0
	4	0
	3	AF Activation Time (H)
	2	
	1	
	0	
5	7	0
	6	0
	5	0
	4	0
	3	AF Activation Time (L)
	2	
	1	
	0	

Byte	Bit	Comments
6	7	0
	6	0
	5	0
	4	0
	3	AF Interval Time (H)
	2	
	1	
	0	
7	7	0
	6	0
	5	0
	4	0
	3	AF Interval Time (L)
	2	
	1	
	0	
8	7	0
	6	0
	5	0
	4	0
	3	1
	2	0
	1	0
	0	0
9	7	0
	6	0
	5	0
	4	0
	3	1
	2	0
	1	0
	0	0
10	7	0
	6	0
	5	0
	4	0
	3	0
	2	0
	1	0
	0	0

Byte	Bit	Comments
11	7	0
	6	0
	5	0
	4	0
	3	0
	2	1
	1	1
	0	1
12	7	0
	6	0
	5	0
	4	0
	3	0
	2	0
	1	0
	0	1
13	7	0
	6	0
	5	0
	4	0
	3	0
	2	NR Level
	1	
	0	
7	0	
14	6	0
	5	0
	4	0
	3	0
	2	AE Gain Limit
	1	
	0	
	7	
15	6	1
	5	1
	4	1
	3	1
	2	1
	1	1
	0	1

Enlargement Function2 Query Command..... Command Packet 8x 09 7E 7E 04 FF

Byte	Bit	Comments
0	7	Destination Address
	6	
	5	
	4	
	3	Source Address
	2	
1		
1	0	0 Completion Message (50h)
	7	
	6	
	5	
	4	
	3	
	2	
	1	
2	0	WideD mode (0: OFF, 1: ON, 2: Auto ON/OFF, 3: ON (RatioFlx), 4: ON (Dver))
	7	
	6	
	5	
	4	
3	0	WideD screen display 0: Combined image 1: Long/short division 2: Long-time 3: Short-time
	7	
	6	
	5	
	4	
	3	
4	0	WideD detection sensitivity 0: L 1: M 2: H
	7	
	6	
	5	
	4	
	3	
5	0	WideD blocked-up shadow correction level 0: L 1: M 2: H 3: S
	7	
	6	
	5	
	4	
	3	
6	0	WideD blown-out highlight correction level 0: L 1: M 2: H
	7	
	6	
	5	
	4	
	3	
7	0	WideD short exposure Exposure ratio (L)
	7	
	6	
	5	
	4	
	3	
8	0	0
	7	
	6	
	5	
	4	
	3	
	2	
	1	
9	0	0
	7	
	6	
	5	
	4	
	3	
10	0	0
	7	
	6	
	5	
	4	
	3	
11	0	0
	7	
	6	
	5	
	4	
	3	

Byte	Bit	Comments
6	0	0
	7	
	6	
	5	
	4	
	3	
	2	
	1	
7	0	0
	7	
	6	
	5	
	4	
	3	
	2	
	1	
8	0	0
	7	
	6	
	5	
	4	
	3	
	2	
	1	
9	0	0
	7	
	6	
	5	
	4	
	3	
10	0	0
	7	
	6	
	5	
	4	
	3	
11	0	0
	7	
	6	
	5	
	4	
	3	

Byte	Bit	Comments
12	0	0
	7	
	6	
	5	
	4	
	3	
	2	
	1	
13	0	0
	7	
	6	
	5	
	4	
	3	
	2	
	1	
14	0	0
	7	
	6	
	5	
	4	
	3	
	2	
	1	
15	0	1 Terminator (FFh)
	7	
	6	
	5	
	4	
	3	
	2	
	1	

VISCA Command Setting Values

Exposure Control (1/2)

		NTSC (s)	PAL (s)
Shutter Speed	15	1/10000	1/10000
	14	1/6000	1/6000
	13	1/4000	1/3500
	12	1/3000	1/2500
	11	1/2000	1/1750
	10	1/1500	1/1250
	0F	1/1000	1/1000
	0E	1/725	1/600
	0D	1/500	1/425
	0C	1/350	1/300
	0B	1/250	1/215
	0A	1/180	1/150
	09	1/125	1/120
	08	1/100	1/100
	07	1/90	1/75
	06	1/60	1/50
	05	1/30	1/25
	04	1/15	1/12
	03	1/8	1/6
	02	1/4	1/3
01	1/2	1/2	
00	1/1	1/1	
Iris	11	F1.4 (F1.35)	
	10	F1.6	
	0F	F2	
	0E	F2.4	
	0D	F2.8	
	0C	F3.4	
	0B	F4	
	0A	F4.8	
	09	F5.6	
	08	F6.8	
	07	F8	
	06	F9.6	
	05	F11	
	04	F14	
	03	F16	
	02	F19	
01	F22		
00	CLOSE		

* Number in () applies to EVI-D90N/P only.

Gain	0F	+28 dB
	0E	+26 dB
	0D	+24 dB
	0C	+22 dB
	0B	+20 dB
	0A	+18 dB
	09	+16 dB
	08	+14 dB
	07	+12 dB
	06	+10 dB
	05	+8 dB
	04	+6 dB
	03	+4 dB
	02	+2 dB
	01	0 dB
	00	-3 dB
Gain Limit	0F	+28 dB
	0E	+26 dB
	0D	+24 dB
	0C	+22 dB
	0B	+20 dB
	0A	+18 dB
	09	+16 dB
	08	+14 dB
	07	+12 dB
	06	+10 dB
05	+8 dB	
04	+6 dB	

Exposure Control (2/2)

		IRIS	GAIN
Bright	1F	F1.4 (F1.35)	+28 dB
	1E	F1.4 (F1.35)	+26 dB
	1D	F1.4 (F1.35)	+24 dB
	1C	F1.4 (F1.35)	+22 dB
	1B	F1.4 (F1.35)	+20 dB
	1A	F1.4 (F1.35)	+18 dB
	19	F1.4 (F1.35)	+16 dB
	18	F1.4 (F1.35)	+14 dB
	17	F1.4 (F1.35)	+12 dB
	16	F1.4 (F1.35)	+10 dB
	15	F1.4 (F1.35)	+8 dB
	14	F1.4 (F1.35)	+6 dB
	13	F1.4 (F1.35)	+4 dB
	12	F1.4 (F1.35)	+2 dB
	11	F1.4 (F1.35)	0 dB
	10	F1.6	0 dB
	0F	F2	0 dB
	0E	F2.4	0 dB
	0D	F2.8	0 dB
	0C	F3.4	0 dB
	0B	F4	0 dB
	0A	F4.8	0 dB
	09	F5.6	0 dB
	08	F6.8	0 dB
	07	F8	0 dB
	06	F9.6	0 dB
	05	F11	0 dB
	04	F14	0 dB
	03	F16	0 dB
	02	F19	0 dB
01	F22	0 dB	
00	CLOSE	0 dB	
Exposure Comp.	0E	+7	+10.5 dB
	0D	+6	+9 dB
	0C	+5	+7.5 dB
	0B	+4	+6 dB
	0A	+3	+4.5 dB
	09	+2	+3 dB
	08	+1	+1.5 dB
	07	0	0 dB
	06	-1	-1.5 dB
	05	-2	-3 dB
	04	-3	-4.5 dB
	03	-4	-6 dB
	02	-5	-7.5 dB
	01	-6	-9 dB
00	-7	-10.5 dB	

* Number in () applies to EVI-D90N/P only.

**Zoom Ratio and Zoom Position (for reference)
(EVI-D80N/P)**

Zoom Ratio ×36 Lens	Optical Zoom Position Data
×1	0000
×2	1804
×3	2296
×4	28F0
×5	2D58
×6	30AA
×7	3350
×8	357E
×9	3758
×10	38EF
×11	3A52
×12	3B84
×13	3C90
×14	3D7A
×15	3E42
×16	3EEE
×17	3F82
×18	4000

**Zoom Ratio and Zoom Position (for reference)
(EVI-D90N/P)**

Zoom Ratio ×36 Lens	Optical Zoom Position Data
×1	0000
×2	15CA
×3	1F65
×4	2527
×5	2921
×6	2C22
×7	2E88
×8	3088
×9	3242
×10	33C9
×11	3529
×12	366C
×13	3795
×14	38A8
×15	39A5
×16	3A8E
×17	3B61
×18	3C1E
×19	3CC7
×20	3D5C
×21	3DDE
×22	3E50
×23	3EB3
×24	3F09
×25	3F53
×26	3F94
×27	3FCD
×28	4000

X12-NTSC/PAL

Digital Zoom Ratio	Digital Zoom Position Data
×1	4000
×2	6000
×3	6A80
×4	7000
×5	7300
×6	7540
×7	76C0
×8	7800
×9	78C0
×10	7980
×11	7A00
×12	7AC0

Lens control (EVI-D80N/P)

Zoom Position	0000 to 4000 to 7AC0 Wide end Optical Digital Tele end Tele end															
Focus Position	1000 to C000* Far end Near end * Depending on the Focus Near Limit setting.															
Focus Near Limit	<table border="1"> <tbody> <tr> <td>1000: Over Inf</td> <td rowspan="10">As the distance on the left will differ due to temperature characteristics, etc., use as approximate values. * The lower 1 byte is fixed at 00.</td> </tr> <tr> <td>2000: 8 m</td> </tr> <tr> <td>3000: 3.5 m</td> </tr> <tr> <td>4000: 2 m</td> </tr> <tr> <td>5000: 1.4 m</td> </tr> <tr> <td>6000: 1 m</td> </tr> <tr> <td>7000: 80 cm</td> </tr> <tr> <td>8000: 29 cm</td> </tr> <tr> <td>9000: 10 cm</td> </tr> <tr> <td>A000: 4.7 cm</td> </tr> <tr> <td>B000: 2.3 cm</td> <td></td> </tr> <tr> <td>C000: 1 cm</td> <td></td> </tr> </tbody> </table>	1000: Over Inf	As the distance on the left will differ due to temperature characteristics, etc., use as approximate values. * The lower 1 byte is fixed at 00.	2000: 8 m	3000: 3.5 m	4000: 2 m	5000: 1.4 m	6000: 1 m	7000: 80 cm	8000: 29 cm	9000: 10 cm	A000: 4.7 cm	B000: 2.3 cm		C000: 1 cm	
1000: Over Inf	As the distance on the left will differ due to temperature characteristics, etc., use as approximate values. * The lower 1 byte is fixed at 00.															
2000: 8 m																
3000: 3.5 m																
4000: 2 m																
5000: 1.4 m																
6000: 1 m																
7000: 80 cm																
8000: 29 cm																
9000: 10 cm																
A000: 4.7 cm																
B000: 2.3 cm																
C000: 1 cm																

Lens control (EVI-D90N/P)

Zoom Position	0000 to 4000 to 7AC0 Wide end Optical Digital Tele end Tele end															
Focus Position	1000 to C000* Far end Near end * Depending on the Focus Near Limit setting.															
Focus Near Limit	<table border="1"> <tbody> <tr> <td>1000: Over Inf</td> <td rowspan="10">As the distance on the left will differ due to temperature characteristics, etc., use as approximate values. * The lower 1 byte is fixed at 00.</td> </tr> <tr> <td>2000: 12 m</td> </tr> <tr> <td>3000: 5.6 m</td> </tr> <tr> <td>4000: 4 m</td> </tr> <tr> <td>5000: 2.7 m</td> </tr> <tr> <td>6000: 2 m</td> </tr> <tr> <td>7000: 1.5 m</td> </tr> <tr> <td>8000: 80 cm</td> </tr> <tr> <td>9000: 30 cm</td> </tr> <tr> <td>A000: 19 cm</td> </tr> <tr> <td>B000: 9 cm</td> <td></td> </tr> <tr> <td>C000: 1 cm</td> <td></td> </tr> </tbody> </table>	1000: Over Inf	As the distance on the left will differ due to temperature characteristics, etc., use as approximate values. * The lower 1 byte is fixed at 00.	2000: 12 m	3000: 5.6 m	4000: 4 m	5000: 2.7 m	6000: 2 m	7000: 1.5 m	8000: 80 cm	9000: 30 cm	A000: 19 cm	B000: 9 cm		C000: 1 cm	
1000: Over Inf	As the distance on the left will differ due to temperature characteristics, etc., use as approximate values. * The lower 1 byte is fixed at 00.															
2000: 12 m																
3000: 5.6 m																
4000: 4 m																
5000: 2.7 m																
6000: 2 m																
7000: 1.5 m																
8000: 80 cm																
9000: 30 cm																
A000: 19 cm																
B000: 9 cm																
C000: 1 cm																

Others

AF Active Time ¹⁾	00 to FF
AF Interval Time ¹⁾	00 to FF
R Gain	00 to FF
B Gain	00 to FF
Aperture Level	00 to 0F
NR Level	00 to 05
AutoICR ON → OFF Threshold Level	00 to 1C

¹⁾ Unit: One second

Pan/Tilt Status Code List

P	Q	R	S	
----	----	0---	---1	A Pan movement all the way to the left
----	----	0---	--1-	A Pan movement all the way to the right
----	----	0---	-1--	A Tilt movement all the way up
----	----	0---	1---	A Tilt movement all the way down
----	----	--00	----	Pan movement is correct
----	----	--01	----	Pan position cannot be detected
----	--00	0---	----	The Tilt movement is correct
----	--01	0---	----	The Tilt position cannot be detected
----	00--	0---	----	No movement instructions
----	01--	0---	----	In the midst of a Pan/Tilt
----	10--	0---	----	Pan/Tilt completed
----	11--	0---	----	Pan/Tilt failed
--00	----	0---	----	Not initialized
--01	----	0---	----	Initializing
--10	----	0---	----	Initialization completed
--11	----	0---	----	Initialization failed

(- : optional)

Pan/Tilt Position (for reference)

	Parameter (position)
PAN	E1E5 (-170 degree) to 1E1B (+170 degree)
TILT	FC75 (-20 degree) to 0FF0 (+90 degree) (IMAGE FLIP: OFF) F010 (-90 degree) to 038B (+20 degree) (IMAGE FLIP: ON)

LED Status

Status		POWER (Green)	STANDBY (Orange)
Main power ON	Power On (including initializing period)	On	Off
	When receiving infrared signals form Remote Commander	Blinking	Off
	At position detection error	On	Blinking
	Standby status Power off by VISCA or the Remote Commander	Off	On
Main power Off		Off	Off
Initialization error	Pan/tilt error	Blinking	Blinking
	Internal error(LSI, etc.)	Blinking alternately	
BOTTOM switch	Setting error (Example: when the BOTTOM switch 5 is set to ON.)	On	On

D70 Mode

Overview

The D70 mode allows you to control the EVI-D80N/D80P/D90N/D90P using VISCA commands for the EVI-D70/P. Most of the VISCA commands for the EVI-D80N/D80P/D90N/D90P correspond to one for the EVI-D70/P. However, some of the VISCA commands for the EVI-D80N/D80P/D90N/D90P are different from those for the EVI-D70/P in definitions of parameters.

When you send those commands to an EVI-D80N/D80P/D90N/D90P whose D70 mode is set to ON, the camera translates the parameters for the EVI-D70/P to those for the EVI-D80N/D80P/D90N/D90P and executes the command. The following parameters are subject to translation.

- Zoom position
- Pan-tilt speed
- Pan-tilt position

Notes

- Even if you set the D70 mode to ON, the EVI-D80N/D80P/D90N/D90P may not emulate the EVI-D70/P perfectly. This is caused by differences in hardware between the two models.
- The functions that are provided with the EVI-D70/P but not with the EVI-D80N/D80P/D90N/D90P cannot be executed.

Switching the Mode

You can switch the D70 mode ON or OFF by switching the BOTTOM switch at the bottom of the EVI-D80N/D80P/D90N/D90P. To change the D70 mode setting, move the BOTTOM switch to ON or OFF while the camera's power is off or the camera is in standby mode. Then, turn the power on by connecting the camera to an AC outlet or by using the VISCA commands or the Remote Commander.

It takes about 7-16 seconds for the image to be displayed after Pan/Tilt initialization motion has stopped.

Do not turn off DC power until the image has been displayed.

The mode will not change if you change the switch setting of the BOTTOM switch after the power has been turned on.

After you change the mode, previously saved position preset data will be lost. (Zoom, Pan/Tilt positions, etc. will be reset to their initial settings.)

Accepting or Sending Back Commands

When accepting commands

Type of command		D70 mode on	D70 mode off
Common to both the D70 and D80N/D80P/D90N/D90P	Common parameters	Accepts as is	
	Different parameters	Translates the D70's parameters to those of the D80N/D80P/D90N/D90P	Accepts as is
	CAM_Memory Reset	Memorized data items are erased and camera settings return to initial values	Memorized data items are erased
Only for the D80N/D80P/D90N/D90P		Accepts as is	
Only for the D70		Refuses and sends back the SyntaxError message	

When accepting inquiry commands

Type of command		D70 mode on	D70 mode off
Common to both the D70 and D80N/D80P/D90N/D90P	Common parameters	Sends back parameters common to both the D70 and D80N/D80P/D90N/D90P	
	Different parameters	Sends back the D70's parameters translated from those of the D80N/D80P/D90N/D90P	Sends back the D80N/D80P/D90N/D90P's parameters
Only for the D80N/D80P/D90N/D90P		Sends back the D80N/D80P/D90N/D90P's parameters	
Only for the D70		Refuses and sends back the SyntaxError message	

Translating Parameters

Zoom position

There is no change for EVI-D80N/D80P. EVI-D90N/D90P employ an 18× optical zoom lens but there are no translating parameters. The zoom ratio and corresponding position data are as shown in the table below (for reference).

Zoom Ratio × 18 Lens	Optical Zoom Position Data
× 1	0000
× 2	1606
× 3	2151
× 4	2860
× 5	2CB5
× 6	3060
× 7	32D3
× 8	3545
× 9	3727
× 10	38A9
× 11	3A42
× 12	3B4B
× 13	3C85
× 14	3D75
× 15	3E4E
× 16	3EF7
× 17	3FA0
× 18	4000

Pan/tilt speed

The actual speed that is defined by the parameters corresponds to that of the D70.

When the camera receives commands such as PantiltDrive Home, Reset, or CAM_Memory Recall, that do not include speed indications, these operations are carried out at the same speed as they would be when the D70 mode is set to OFF.

Parameters	Speed (deg/sec)			D70
	D80N/ D80P	D90N/ D90P		
01h	1.7	1.3	→	1.7
02h	2.2	1.7	→	2.2
03h	2.9	2.2	→	2.9
04h	4.1	3.2	→	4.1
05h	6.8	5.4	→	6.8
06h	11	11	→	11
07h	16	16	→	16
08h	21	21	→	21
09h	27	27	→	27
0Ah	31	31	→	31
0Bh	35	35	→	35
0Ch	40	40	→	40
0Dh	42	42	→	47
0Eh	44	44	→	49
0Fh	46	46	→	54
10h	48	48	→	56
11h	50	50	→	62
12h	79	79	→	64
13h	81	81	→	69
14h	83	83	→	72
15h	85	85	→	79
16h	87	87	→	84
17h	90	90	→	90
18h ¹⁾	100	100	→	100

1) Max. pan speed is 18h; max. tilt speed is 17h.

Pan/tilt position

Pan position

Cameras	Parameters
EVI-D70/P	F725h (-170 degrees) to 08DBh (+170 degrees)
EVI-D80N/D80P/D90N/D90P	E1E5h (-170 degrees) to 1E1Bh (+170 degrees)

Tilt position

Cameras	Parameters
EVI-D70/P	FE70h (-30 degrees) to 04B0h (+90 degrees)
EVI-D80N/D80P/D90N/D90P	FC75h (-20 degrees) to 0FF0h (+90 degrees)

Translation of commands

Accepting parameters	Translation
Pan position	Multiplies received parameters by 17/5
Tilt position	Multiplies received parameters by 17/5

D70 Pan/Tilt		D80N/D80P/D90N/D90P	
		Pan	Tilt
F725h	➔	E1E5h	-
...		...	-
FEF5h	➔	FC75h	FC75h
...	
FFFDh	➔	FFF6h	FFF6h
FFFEh	➔	FFFAh	FFFAh
FFFFh	➔	FFFDh	FFFDh
0000h	➔	0000h	0000h
0001h	➔	0003h	0003h
0002h	➔	0006h	0006h
0003h	➔	000Ah	000Ah
0004h	➔	000Dh	000Dh
0005h	➔	0011h	0011h
0006h	➔	0014h	0014h
0007h	➔	0017h	0017h
0008h	➔	001Bh	001Bh
0009h	➔	001Eh	001Eh
000Ah	➔	0022h	0022h
000Bh	➔	0025h	0025h
...		...	-
04B0h	➔	0FF0h	0FF0h
...		...	-
08DBh	➔	1E1Bh	-

Translation when answering inquiry commands

The camera sends back values that are calculated by inverse conversion performed when the camera accepts commands.

Note

Repetitive use of the Absolute position command may increase the variance that is accumulated from translation.

Example

When you execute the Relative position command 100 times, one step after another to turn the camera to the right side:

Cameras	Results
EVI-D70/P	Turns to the right side by 7.5 degrees.
EVI-D80N/D80P/D90N/D90P whose D70 mode is ON	Turns to the right side by 6.6 degrees.

For Absolute Position commands, the permissible range for drive settings are the same as those for the EVI-D70/P.

Pan direction: -170 degrees to + 170 degrees.

Tilt direction: -20 degrees to + 90 degrees.

Specifications

System

Video signal	EVI-D80N/EVI-D90N: NTSC EVI-D80P/EVI-D90P: PAL
Synchronization	Internal synchronization
Image device	EVI-D80N/EVI-D80P: 1/4 type CCD EVI-D90N/EVI-D90P: 1/4 type EXview HAD CCD
Lens	EVI-D80N/EVI-D80P: 18× (optical), 12× (digital) f = 4.1 – 73.8 mm, F1.4 – F3.0 Horizontal angle: 2.8 (TELE end) to 48.0 degrees (WIDE end) EVI-D90N/EVI-D90P: 28× (optical), 12× (digital) f = 3.5 – 98.0 mm, F1.35 – F3.7 Horizontal angle: 2.1 (TELE end) to 55.8 degrees (WIDE end)
Minimum object distance	EVI-D80N/EVI-D80P: 10 mm (0.4 inches) (WIDE end) to 800 mm (31.5 inches) (TELE end) 290 mm (11 27/64 inches) (Default) EVI-D90N/EVI-D90P: 10 mm (0.4 inches) (WIDE end) to 1500 mm (59 1/16 inches) (TELE end) 300 mm (11 13/16 inches) (Default)
Minimum illumination	EVI-D80N/EVI-D80P: less or equal to 0.4 lux (F1.4) with 50 IRE EVI-D90N/EVI-D90P: less or equal to 0.65 lux (F1.35) with 50 IRE
Shutter speed	1 to 10,000 sec.
Video S/N	More or equal to 50 dB
Pan/tilt action	Horizontal: ±170 degrees Maximum panning speed: 100 degrees/sec. Vertical: +90, -20degrees Maximum tilting speed: 90 degrees/sec.

Input/output connectors

Video output	COMPOSITE (VBS VIDEO OUT): RCA phono jack (1), 75 ohm unbalanced, 1Vpp (at 75-ohm termination) Synchronization: negative S VIDEO output (Y/C VIDEO OUT): Mini DIN 4-pin type
Control input/output	VISCA IN: Mini DIN 8-pin type, RS-232C VISCA OUT: Mini DIN 8-pin type, RS-232C VISCA RS-422: 9-pin
Power connector	JEITA type4 (DC 12V)

General

Input voltage	12 V DC (10.8 to 13.2 V DC)
Current consumption	EVI-D80N/EVI-D80P: 0.5 A max. (at 12 V DC) EVI-D90N/EVI-D90P: 0.67 A max. (at 12 V DC)
Operating temperature	0 °C to 40 °C (32 °F to 104 °F)
Storage temperature	-20 °C to +60 °C (-4 °F to 140 °F)
Dimensions	Video camera: 145 × 164 × 164 mm (5 1/32 × 6 15/32 × 6 15/32 inches) (w/h/d, excluding protruding parts) Remote Commander: 56 × 26 × 210 mm (2 1/4 × 1 1/16 × 8 3/8 inches) (w/h/d)
Mass	Video camera: EVI-D80N/EVI-D80P: 1440 g (3 lb 2 3/4 oz) EVI-D90N/EVI-D90P: 1460 g (3 lb 3 1/2 oz) Remote Commander: 110 g (3 7/8 oz)
Installation angle	Less than ±15 degrees to the horizontal surface

Supplied accessories

AC power adaptor (MPA-AC1)
(AC 100 V, 50/60 Hz) (1)

AC power cord (1)

Remote Commander (RM-EV100) (1)

Ceiling bracket (A) (1)

Ceiling bracket (B) (1)

Wire rope (1)

Screw M3 × 8 (8)

VISCA RS-422 connector plug (1)

Operating Instructions (1)

Design and specifications are subject to change without notice.

Note

Always verify that the unit is operating properly before use. SONY WILL NOT BE LIABLE FOR DAMAGES OF ANY KIND INCLUDING, BUT NOT LIMITED TO, COMPENSATION OR REIMBURSEMENT ON ACCOUNT OF THE LOSS OF PRESENT OR PROSPECTIVE PROFITS DUE TO FAILURE OF THIS UNIT, EITHER DURING THE WARRANTY PERIOD OR AFTER EXPIRATION OF THE WARRANTY, OR FOR ANY OTHER REASON WHATSOEVER.

Dimensions

Top

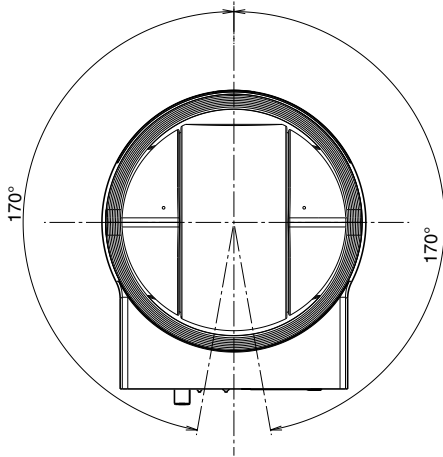

Back

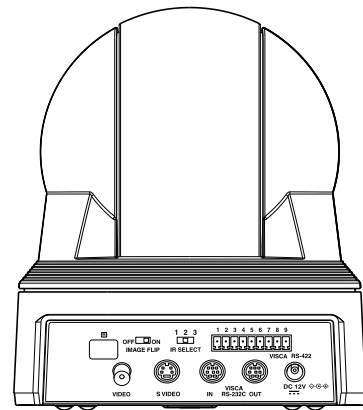

Front

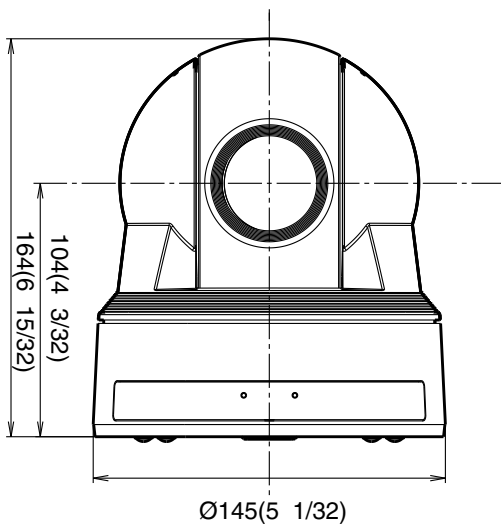

Side

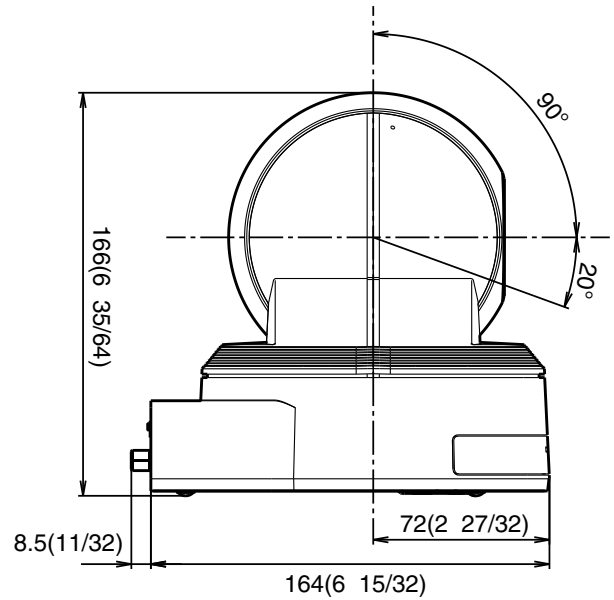

Bottom

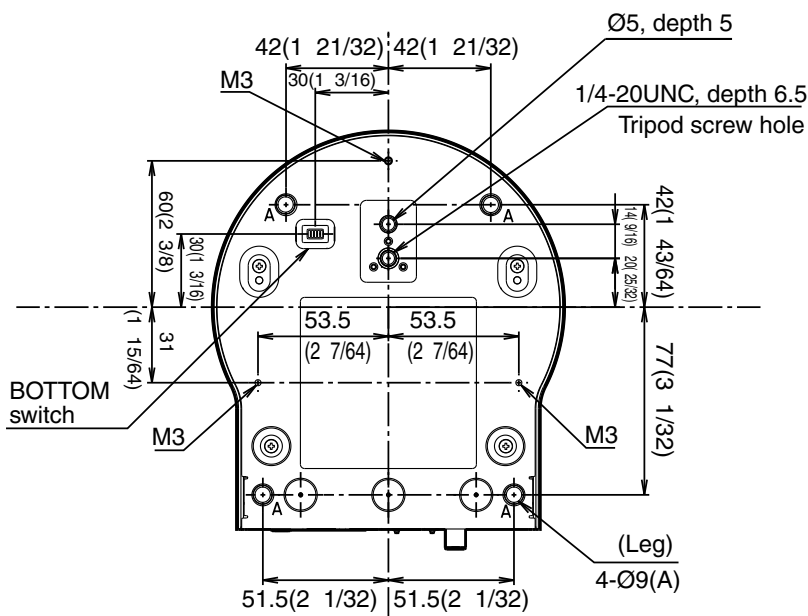

Unit: mm (inches)

Precautions

Software

Use of the demonstration software developed by Sony Corporation or use of the software with customer developed application software may damage hardware, the application program or the camera. Sony Corporation is not liable for any damages under these conditions.

Operation

Start the camera control software on your computer after you turn on the camera and the image is displayed.

Operation and storage locations

Do not shoot images that are extremely bright (e.g., light sources, the sun, etc.) for long periods of time. Do not use or store the camera in the following extreme conditions:

- Extremely hot or cold places (operating temperature 0 °C to 40 °C (32 °F to 104 °F))
- Close to generators of powerful electromagnetic radiation such as radio or TV transmitters
- Where it is subject to fluorescent light reflections
- Where it is subject to unstable (flickering, etc.) lighting conditions
- Where it is subject to strong vibration

Care of the unit

Remove dust or dirt on the surface of the lens with a blower (commercially available).

Other

Do not apply excessive voltage. (Use only the specified voltage.) Otherwise, you may get an electric shock or a fire may occur.

In case of abnormal operation, contact your authorized Sony dealer or the store where you purchased the product.