

AMS16-2AM & AMS16-2AEM

16 CHANNEL AUDIO MONITORING SYSTEM



by Ward-Beck Systems

Rev:Nov.07 2014

Cautionary Information

There are no user serviceable components in this unit. Repairs and calibration should only be performed by factory trained personnel.

Removing the top cover of this unit will expose the user to potentially lethal AC voltages and will void the warranty.

Contact our Service department:

416-335-5999 or toll free 800-771-2556

In Case of Problems

Should any problem arise with your unit, please contact the Ward-Beck Technical Support Department. A Return Material Authorization number (RMA) will be issued to you, as well as specific shipping instructions, should you wish our factory to repair your unit. If required, a temporary replacement unit will be made available at a nominal charge. Any shipping costs incurred will be the responsibility of you, the customer. All products shipped to you from Ward-Beck Systems Ltd. will be shipped collect. The Ward-Beck Technical Support Department will continue to provide advice on any product manufactured by Ward-Beck Systems, beyond the warranty period without charge, for the life of the equipment.

Chapter 1

Introduction

1.1 Features

- Two SDI inputs (3G-SDI, HD-SDI or SD-SDI)
- Two reclocked SDI outputs of the selected input
- Up to eight de-embedded AES unbalanced outputs (sixteen channels) from selected SDI source
- Sixteen 58-segment tri-color LED bar-graph level meters with simultaneous PPM dot over VU bar
- Can optionally decode Dolby E or AC-3 (on AMS16-2AEM model)
- Dolby Metadata output on 9 pin DB9-M connector (Optional - AMS16-2AEM model)
- Eight analog outputs on a DB-25 connector
- Multi-channel to stereo downmix capability
- Stereo mixing
- Two internal speakers
- Headset output
- Correlation display of selected channels

Chapter 2

Installation and User Interface

This chapter provides information on unpacking and installation of the unit and a description of the inputs, outputs and user interface located on the front and rear panels.

2.1 Unpacking

Please inspect the unit carefully to ensure that damage has not occurred during shipping. Report any damage immediately to the factory and note any obvious damage to the packaging.

2.2 Installation and Setup

2.2.1 Mounting

The AMS16-2 mounts in a standard 19 inch rack and occupies two rack units of space.

2.2.2 Cable Connections

Connections to the unit are made on the rear panel. Refer to section 2.4 for a description of each connection.

HD-SDI maximum cable length using Delco 394167 cable or equivalent is 100 Meters (328 feet). 3G-SDI maximum cable length using Delco 394167 cable or equivalent is 75 Meters (246 feet).

2.3 Front Panel User Interface

The following section lists and describes the features located on the front panel of the AMS16-2 series. Figure 2.3-1 illustrates the location of each feature.

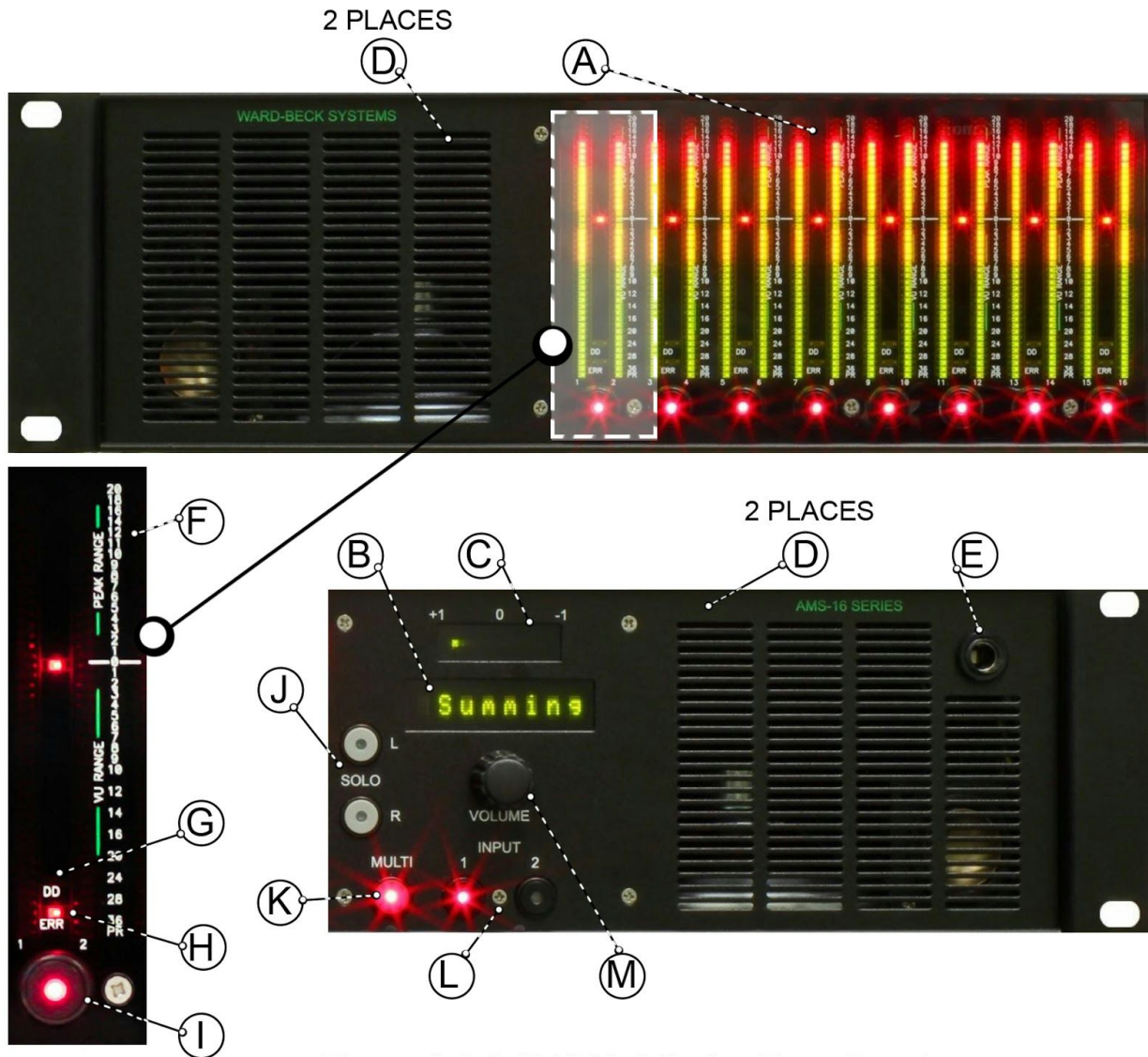

Figure 2.3-1 AMS16-2 Series Front Panel

2.3.1 Audio Level Meters (1-16)

- Ⓐ Sixteen 58-segment tri-colour LED bar-graph meters with simultaneous PPM dot over VU bar indicate the de-embedded audio levels. The meters are divided into eight AES pairs.

2.3.2 Alphanumeric Display

- Ⓑ Eight character Alphanumeric Display used to display necessary information.

2.3.3 Correlation Meter

- Ⓒ Indicator of the phase relationship between the left and right channel of the monitored AES pair.

2.3.4 Internal Speakers

- Ⓓ A set of mid-range and woofer speakers are located on the left and right side of the unit allowing audio monitoring as a stereo pair.

2.3.5 Headset Jack

- Ⓔ Audio can be monitored using a headset. Plugging in the headset will mute the internal speakers.

2.3.6 Audio Level Indicator

- Ⓕ These numbers indicate the difference between the audio level and reference level in dBFS. The factory default reference level is set to -20 dBFS and is indicated by the zero reference mark on the Audio Level Indicator. The reference level is adjustable in the configuration menu.

2.3.7 DD LED

- Ⓖ Optional on the AMS16-2AEM model: A yellow LED indicating that a Dolby E or AC-3 signal is present at the specified de-embedded audio location when illuminated.

2.3.8 ERR LED

-  A red LED indicating that no valid audio data is present at the specified de-embedded audio location when illuminated.

2.3.9 Audio Monitor Select

-  Eight Audio Monitor Select pushbuttons are located below the eight pairs of AES Audio Level Meters. The Monitor Select pushbutton instructs the unit to monitor the selected AES signal. Pushbutton will illuminate when selected.

2.3.10 L (Left) and R (Right) Channel Solo

-  When pressed, the L or R SOLO pushbutton will illuminate, audio from a single left or right channel is heard on the internal speakers and a mono output of the left or right channel is present on the rear MONITOR output. Return to the normal monitoring state by pressing the illuminated L or R pushbutton again.

2.3.11 MULTI Mode Select

-  Press the MULTI Mode pushbutton to cycle between Demux, Dolby, Multi (Downmix) and Summing modes. Refer to chapter three for full details on settings and applications for each mode.

2.3.12 SDI INPUT Select

-  SDI INPUT Select pushbutton allows the user to monitor SDI IN1 or IN2. When selected, the pushbutton will illuminate.

2.3.13 Volume Control

-  Rotate knob to raise or lower the audio level of the selected signal on the local speakers and MONITOR outputs. Volume Control may affect the levels of the AES and Analog outputs when O/P is set to VAR within the menu settings. The level is displayed in dB over a range that includes OFF and -60 dB to +15 dB in 1dB steps.

Pressing the VOLUME knob once will mute. Pressing the knob again will un-mute. When audio is muted, the character read-out will display Mute.

2.4 Rear Panel Connections

The following section lists and describes the connections located on the rear panel of the AMS16-2. Figure 2.4-1 illustrates the location of each connector.

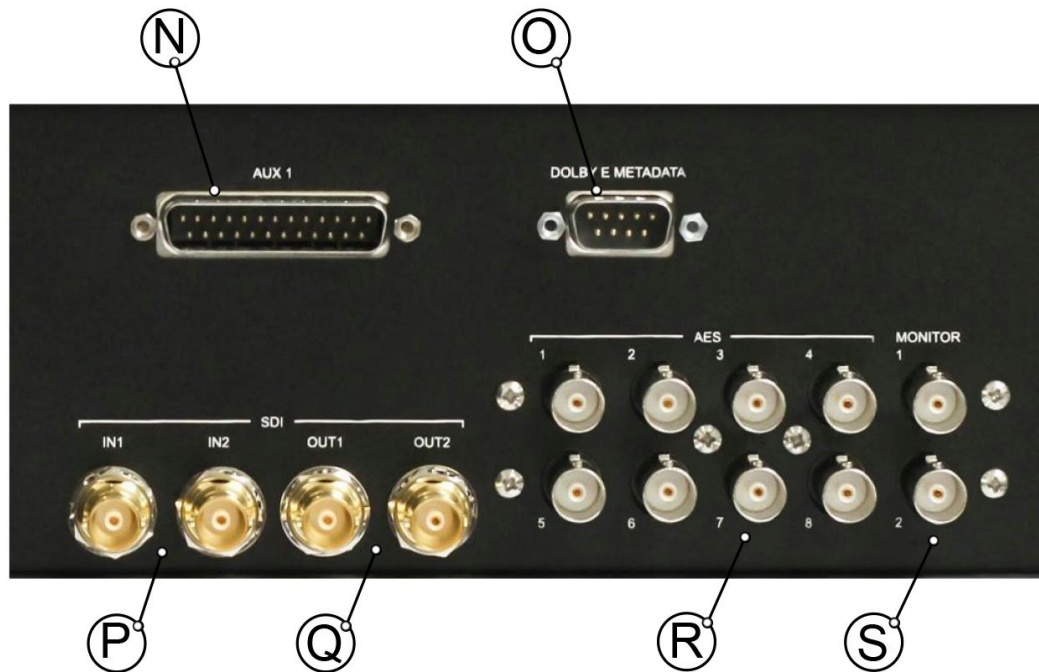

Figure 2.4-1 AMS16- 2 Series Rear Panel (with optional AMS16-2AEM Dolby Metadata Output added)

2.4.1 Analog Audio Output (AUX1)

- N** A configurable eight channel Analog Audio Output is available for surround sound or stereo audio monitoring on an external device.

2.4.2 Dolby E Metadata Output



Output provides a copy of the Dolby E Metadata found within the Dolby stream. Valid Metadata is available only when the unit is in Dolby mode. This connector is only provided on the optional Dolby-installed AMS16-2AEM model.

2.4.3 SDI Input



The unit will accept two SDI signals of standard definition (SD), as per SMPTE 259M, high definition (HD), as per SMPTE 292M formats and 3G-SDI as per SMPTE 424M.

2.4.4 SDI Output



The unit provides two re-clocked SDI outputs of the selected SDI input.

2.4.5 AES Audio Output



The AMS16-2 provides up to eight unbalanced AES audio outputs on BNC connectors. The audio on the rear AES output follows the front panel Audio Level Meters. The relationship is shown on table 2.4-1.

AES Output Number	Audio Level Meter Number*
1	1,2
2	3,4
3	5,6
4	7,8
5	9,10
6	11,12
7	13,14
8	15,16

* An exception to the previous table occurs when surround sound monitoring of Dolby E or AC-3 audio on external speakers. Refer to chapter three for details.

Table 2.4-1 Routing of AES Outputs 1-8

2.4.6 Audio Monitor Output



Two unbalanced BNC Audio Monitor outputs are available for monitoring the selected AES audio. Press one of the eight Audio Monitor Select pushbuttons to monitor the respective digital audio pair.

Chapter 3

Applications

This chapter describes the audio monitoring options and setup for Dolby E, Dolby AC-3 and PCM audio, on the optional Dolby-installed AMS16-2AEM model.

3.1 Embedded Dolby E and AC-3

The AMS16-2AEM will accept and decode Dolby E and Dolby AC-3 signals. When a Dolby signal is demuxed from the SDI video stream the unit indicates its location by illuminating the DD (Dolby detected) LED located above the Monitor Select pushbutton. Refer to figure 2.3-1 for location of DD LED location.

3.1.1 Dolby Decoding

Before attempting to decode a Dolby signal, ensure that:

1. Dolby mode is enabled in the configuration setup menu.
2. Before entering Dolby mode, ensure that the Dolby signal to be decoded is selected by pressing the appropriate Monitor Selector pushbutton within Demux Mode. In Demux Mode, the Alphanumeric display will read HD-SDI or SD-SDI. If your unit is not already in Demux Mode, press the MULTI pushbutton until the character display reads HD-SDI or SD-SDI.

Once the previous two steps are complete, press the MULTI button to access Dolby Mode. In Dolby Mode the Alphanumeric Display will read Dolby-x, where x (1-8) refers to the location of the selected embedded Dolby signal within the SDI stream.

In Dolby mode the Dolby signal is decoded and displayed on the Audio Level Meter according to table 3.1-1.

Audio Meter Number	Dolby Audio Description
1,2	Decoded Audio 1,2
3,4	Decoded Audio 3,4
5,6	Decoded Audio 5,6
7,8	Decoded Audio 7,8
...	...
15,16	Lt, Rt Downmix

Table 3.1-1 Routing of Dolby Decoded Audio to Audio Level Meters

3.1.2 Monitoring Dolby E and AC-3 Audio

Surround Sound Monitoring On External Speakers

The typical configuration settings for external speaker surround sound monitoring of a Dolby E or AC-3 signal are outlined in table 3.1-2.

Menu*	Sub-Menu Setting	Note
O/P	Fix	
Spkr	Off	
Mon	5.1	
Dlby	Yes	
Dn	[Enbd / Dsbd]	Enables / disables dialogue normalization.

AES	Proc	
------------	------	--

* Menus not listed in table do not affect the current mode

Table 3.1-2 Typical Configuration Settings for Monitoring Dolby E or AC-3 Surround Sound on External Speakers

When monitoring Dolby E or AC-3 surround sound on external speakers, the option of also monitoring individual Dolby E decoded discrete audio pairs or the Lt / Rt downmix as a stereo pair on the left and right speaker (speakers connected to Analog1A and Analog1B) is available. Press the appropriate Monitor Select pushbutton to monitor a single audio pair on the left and right speaker. The centre, low frequency, left surround and right surround (analog outputs Analog2A, Analog2B, Analog3A and Analog3B) speakers are now muted. Note that AES outputs 2 and 3 are also muted. A single Audio Monitor Select pushbutton is illuminated when monitoring a single audio pair.

To return to surround sound monitoring, press one of the first three Audio Monitor Select pushbuttons twice. Notice that the first three Monitor Select pushbuttons illuminate and the system returns to surround sound audio monitoring on the external speakers.

Stereo Lt/Rt Downmix Monitoring On External Speakers

The typical configuration settings for stereo monitoring of Dolby E or AC-3 decoded audio using external speakers are outlined in table 3.1-3.

Menu*	Sub-Menu Setting	Note
O/P	Fix	
Spkr	Off	
Mon	St	
An1	Out8	Out8 set for monitoring the Lt/ Rt downmix. Out1, Out2 and Out3 set for monitoring individual Dolby decoded discrete audio pairs.
Dlby	Yes	
Dn	[Dsbnd / Enbd]	Enables / disables dialogue normalization.
AES	Proc	

* Menus not listed in table do not affect the current mode

Table 3.1-3 Typical Configuration Settings for Stereo Monitoring of Dolby E or AC-3 on External Speakers

The option to monitor individual Dolby decoded discrete audio pairs, or the Lt/Rt downmix is available. Accomplish this by using the appropriate An1 (analog 1) menu setting described in Table 3.1-3.

Stereo Lt/Rt Downmix Monitoring On Internal Speakers

The typical configuration settings for stereo monitoring of Dolby E or AC-3 decoded audio on internal speakers are outlined in table 3.1-4.

Menu*	Sub-Menu Setting	Note
O/P	Fix	
Spkr	On	
Mon	St	
Dlby	Yes	
Dn	[Enbd / Dsbd]	Enables / disables dialogue normalization.
AES	Proc	

* Menus not listed in table do not affect the current mode

Table 3.1-4 Typical Configuration Menu Settings for Stereo Monitoring of Dolby E or AC-3 On Internal Speakers

The option of switching between audio monitoring of the individual Dolby decoded discrete audio pairs, or the Lt/Rt downmix is available. Press the appropriate Audio Monitor Select pushbutton to do so. Refer to table 3.1-1 for Dolby decoded audio and Lt/Rt locations on the Audio Level Meter.

3.1.3 Monitoring Dolby E Metadata

Valid Metadata is available when decoding Dolby E audio only. Refer to sections 2.4.4 and 5.2.2 for further details.

3.2 Embedded AES Audio

The AMS16-2 will demux AES audio embedded in the SDI video stream. The unit indicates that audio is present on a specified channel by illuminating the Audio Level Meters. When the ERR LED is illuminated, valid digital audio data is not present on the indicated Audio Level Meter location.

3.2.1 Demuxing Embedded AES Audio from the MD-SDI Video Stream

Before attempting to monitor AES audio ensure that:

1. A standard definition (SD), as per SMPTE 259M, or high definition (HD), as per SMPTE 292M or 3G-SDI (3G) as per SMPTE 424M signal with embedded audio is connected to rear SDI Input 1 or 2.
2. Ensure that the SDI Input Select 1 or 2 pushbutton corresponding to the rear SDI Input 1 or 2 is selected.

In Demux Mode, the character display reads HD-SDI or SD-SDI corresponding to the video format connected to the rear SDI Input of the AMS16-2. If your unit is not already in Demux Mode, press the MULTI pushbutton until the character display reads HD-SDI or SD-SDI. Demux mode allows the user to demux the embedded AES audio and displays it according to table 3.2-1 on the Audio Level Meters.

Audio Level Meter Number	Audio Description
1,2	Embedded Audio 1,2
3,4	Embedded Audio 3,4
5,6	Embedded Audio 5,6
7,8	Embedded Audio 7,8
9,10	Embedded Audio 9,10
11,12	Embedded Audio 11,12
13,14	Embedded Audio 13,14
15,16	Embedded Audio 15,16

Table 3.2-1 Routing of Demuxed Audio to Audio Level Meters

3.2.2 Monitoring Demuxed Audio

Stereo Monitoring On External Speakers

The typical configuration settings for stereo monitoring on external speakers are outlined in table 3.2-3.

Menu*	Sub-Menu Setting	Note
O/P	Fix	
Spkr	Off	

Mon	St	
An1	Mon	
AES	Dmx	

* Menus not listed in table do not affect the current mode

Table 3.2-3 Typical Configuration Settings for External Speaker Stereo Monitoring of Demuxed Audio

Monitor the desired AES audio by pressing the appropriate Monitor Select pushbutton.

Stereo Monitoring On Internal Speakers

The typical configuration settings for stereo monitoring on internal speakers are outlined in table 3.2-4.

Menu*	Sub-Menu Setting	Note
O/P	Fix	
Spkr	On	
Mon	St	
AES	Dmx	

* Menus not listed in table do not affect the current mode

Table 3.2-4 Typical Configuration Settings for Internal Speaker Stereo Monitoring of Demuxed Audio

Monitor the desired AES audio pair by pressing the appropriate Monitor Select pushbutton.

3.2.3 Summing Demuxed Audio

Access Summing Mode by pressing the MULTI button until the character read-out displays Summing. This mode allows for a summing of the selected AES audio pairs. The Monitor Select pushbuttons belonging to the summed audio, remains illuminated until they are de-selected by pressing the illuminated pushbutton again. Note that raw Dolby E and Dolby AC-3 are ignored if selected to be summed, on the optional Dolby-installed AMS16-2AEM model. The summed audio is routed to the two rear BNC MONITOR outputs and the configured Analog monitor outputs.

3.2.4 Monitoring Summed Audio

Stereo Monitoring On External Speakers

The typical configuration settings for stereo monitoring of summed audio on external speakers are outlined in table 3.1-9.

Menu*	Sub-Menu Setting	Note
O/P	Fix	
Spkr	Off	
Mon	St	
An1	Mon	
Sum	Yes	
AES	Proc	

* Menus not listed in table do not affect the current mode

Table 3.2-5 Configuration Settings for Stereo Monitoring of Summed Audio on External Speakers
Stereo Monitoring On Internal Speaker

The typical configuration settings for stereo monitoring of summed audio on internal speakers are outlined in table 3.2-6.

Menu*	Sub-Menu Setting	Note
O/P	Fix	
Spkr	On	
Mon	St	
Sum	Yes	
AES	Proc	

* Menus not listed in table do not affect the current mode

Table 3.2-6 Configuration Settings for Stereo Monitoring of Summed Audio on Internal Speakers

3.2.5 Creating Lt / Rt Downmix of Demuxed AES Audio

Access Multi (Downmix) Mode by pressing the multi button until the character read-out displays Multi. This mode allows the user to create a Lt/Rt downmix of the first three embedded AES audio pairs. Note that Dolby E or AC-3 cannot be present on the first three AES pairs for the Lt/Rt downmix to function.

The Lt/Rt downmix is displayed on the 15th and 16th Audio Level Meter by setting A8 in the setup menu to Lt/Rt. The Lt/Rt mixing proportions are as follows:

$$Lt = (1.0 * L) + (0.707 * C) + (0.707 * Ls) + (0.707 * Rs)$$

$$Rt = (1.0 * R) + (0.707 * C) + (0.707 * Ls) + (0.707 * Rs)$$

3.2.6 Monitoring Lt / Rt Downmix of Embedded AES Audio

In both external and internal speaker monitoring modes, the user can choose between monitoring the individual embedded audio pairs by pressing the appropriate Audio Monitor Select pushbutton or return to monitoring the Lt / Rt downmix by pressing Audio Monitor Select pushbutton eight.

Stereo Monitoring On External Speakers

The typical configuration settings for stereo monitoring of the Lt/Rt downmix on external speakers are outlined in table 3.2-7.

Menu*	Sub-Menu Setting	Note
O/P	Fix	
Spkr	Off	
Mon	St	
An1	Mon	
Mlti	Yes	
A8	LtRt	
AES	Proc	

* Menus not listed in table do not affect the current mode

Table 3.2-7 Configuration Settings for Stereo Monitoring of Lt/Rt Downmix on External Speakers

Stereo Monitoring On Internal Speaker

The typical configuration settings for stereo monitoring of the Lt/Rt downmix on internal speakers are outlined in table 3.2-8.

Menu*	Sub-Menu Setting	Note
O/P	Fix	
Spkr	On	
Mon	St	
Mlti	Yes	

A8	Lt/Rt	
AES	Proc	

* Menus not listed in table do not affect the current mode

Table 3.2-8 Configuration Settings for Stereo Monitoring of Lt/Rt Downmix on Internal Speakers

3.3 Speaker Setup

The external speaker setup for surround sound and stereo monitoring is illustrated in figures 3.3-1 and 3.3-2.

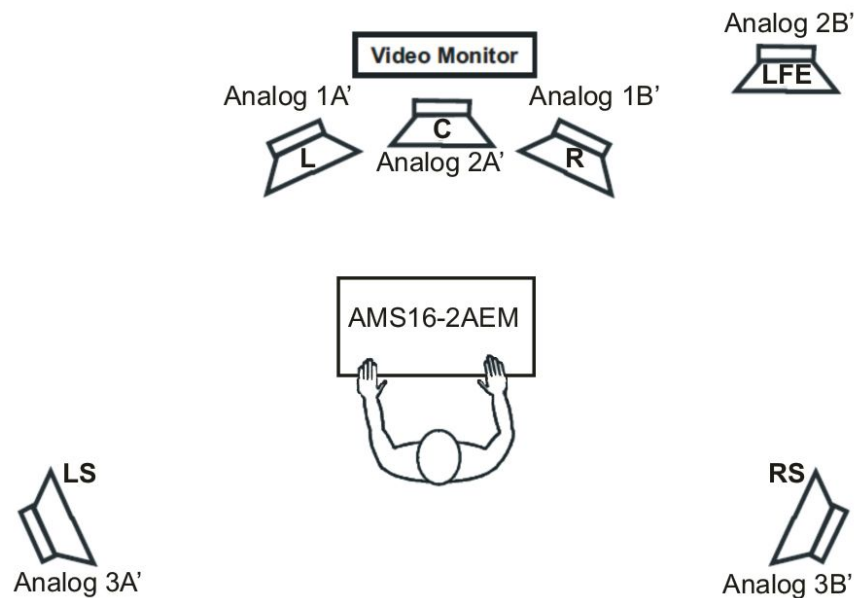

Figure 3.3-1 Speaker Setup for Surround Sound Monitoring of Dolby E or AC-3 On External Speakers

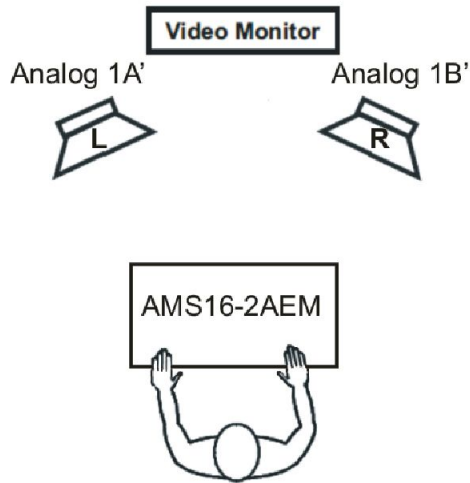

Figure 3.3-2 Speaker Setup for Stereo Monitoring on External Speakers

Chapter 4

Configuration Menu Settings

This chapter provides instructions for accessing the configuration menu settings and details on each setting.

4.1 Accessing the Configuration Menu

A few rudimentary set ups may be performed by the user. To place the AMS16-2 in Configuration Setup mode press and hold the volume control and the two input select buttons simultaneously. The character read-out will now display the current firmware version in the unit eg. 2.x.x.x. Cycle through the menu options by pressing the volume control knob. Rotate the volume control knob to change sub-menu settings relative to its menu option. Figure 4.1-1 illustrates the menu and sub-menu options via a menu flow diagram.

Configuration settings are stored in the eeprom after one minute of inactivity and will be used as default settings on future power ups.

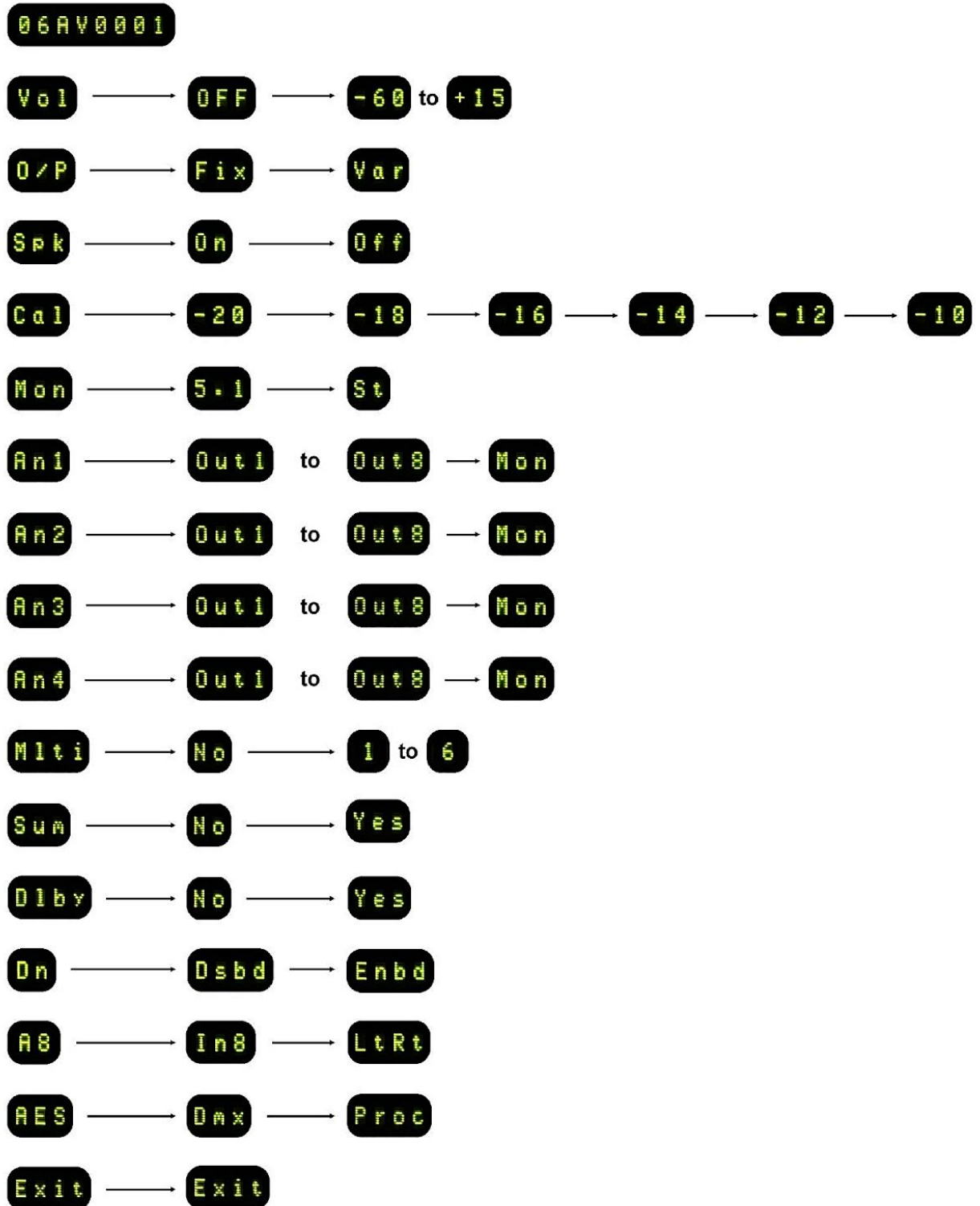

Figure 4.1-1 Configuration Menu Flow Diagram

4.2 Menu Descriptions

4.2.1 Firmware Version

The first menu option displays the current firmware version. It is useful to know the firmware version installed in the unit when speaking to the factory about operational issues.

4.2.2 VOL: Power Up Volume

The LCD display will display the characters VOL xx, where xx is a number that represents the volume that the unit will default to on power up. Change this sub-menu setting by rotating the volume control counter clockwise for a lower level or clockwise for a higher level. This feature is particularly valuable in mobile applications where you do not wish all AMS16-2 units to power up at the last level set before power down.

4.2.3 O/P: AES1-8 Output Level Setup

Setting O/P to Var (variable) allows the user to adjust the audio level of AES and Analog outputs located on the rear panel using the volume control knob. Setting O/P to Fix means that the front panel Volume control does not affect the level of these outputs.

4.2.4 Spkr: Internal Speaker On/Off

This setting allows the user to turn on or off the internal speaker.

4.2.5 Cal: Reference Setup

This sets the reference 0 mark of the LED bar graph meters below digital full scale. Settings include -20, -18, -16, -14, -12 and -10 dBFS.

4.2.6 Mon: Surround Sound Setup

This setting is necessary for surround sound audio monitoring. Refer to section 3.1.

4.2.7 An1, An2, An3, An4: Analog Output Setup

Setting of Out1, Out2, Out3, Out4, Out5, Out6, Out7 or Out8 routes embedded AES audio 1 – 8 respectively to the specified analog output. The setting of Mon sets the specified analog output as a monitor output. The analog monitor output is identical in behaviour to the BNC Monitor output.

4.2.8 Mlti: Multi Mode Setup

Set Mlti to Yes (enabling Multi Mode) to produce a Lt/Rt downmix of the first three AES pairs. Refer to chapter three for full details.

4.2.9 Sum: Summing Mode Setup

Set Sum to Yes to enable Summing mode. Refer to chapter three for full details.

4.2.10 Dlby: Dolby Mode Setup (on optional Dolby-installed AMS16-2AEM model)

Enabling Dolby mode, by setting Dlby to Yes, allows the user to decode the selected Dolby E or AC-3 signal. Refer to chapter three for full details.

4.2.11 Dn: Dialogue Normalization Setup

Enabling dialogue normalization causes the AMS16-2AEM to normalize the Dolby audio level to a value read from the metadata. Dialogue Normalization only affects the AMS16-2AEM in Dolby Mode.

4.2.12 A8: AES Output 8 Setup

The A8 menu setting affects Multi mode only. When A8 is set to LtRt, Audio Level Meter pair 8 and rear AES8 BNC will correspond to the Lt/Rt downmix of the first three AES pairs. When In8 is selected, the front meter pair 8 and rear AES8 BNC output will correspond to the eighth AES pair disembedded from the SDI stream.

4.2.13 AES: AES Pre and Post Process Setup

Pre and post processing is set by setting AES to Dmx or Proc respectively. When AES is set to Dmx, the AES audio on AES outputs 1 to 8 are an identical copy of the disembedded audio from the SDI stream. When AES is set to Proc, AES Outputs 1 to 8 are the post processed AES signals disembedded from the SDI stream. Note that this setting does not affect the analog outputs.

4.2.14 Exit

To exit the Configuration Setup and return to normal operation, rotate the volume control knob.

Chapter 5

Technical Specifications

This chapter provides technical details regarding the AMS16-2 such as the system block diagram, specifications for inputs / outputs and pin configurations.

5.1 System Block Diagram

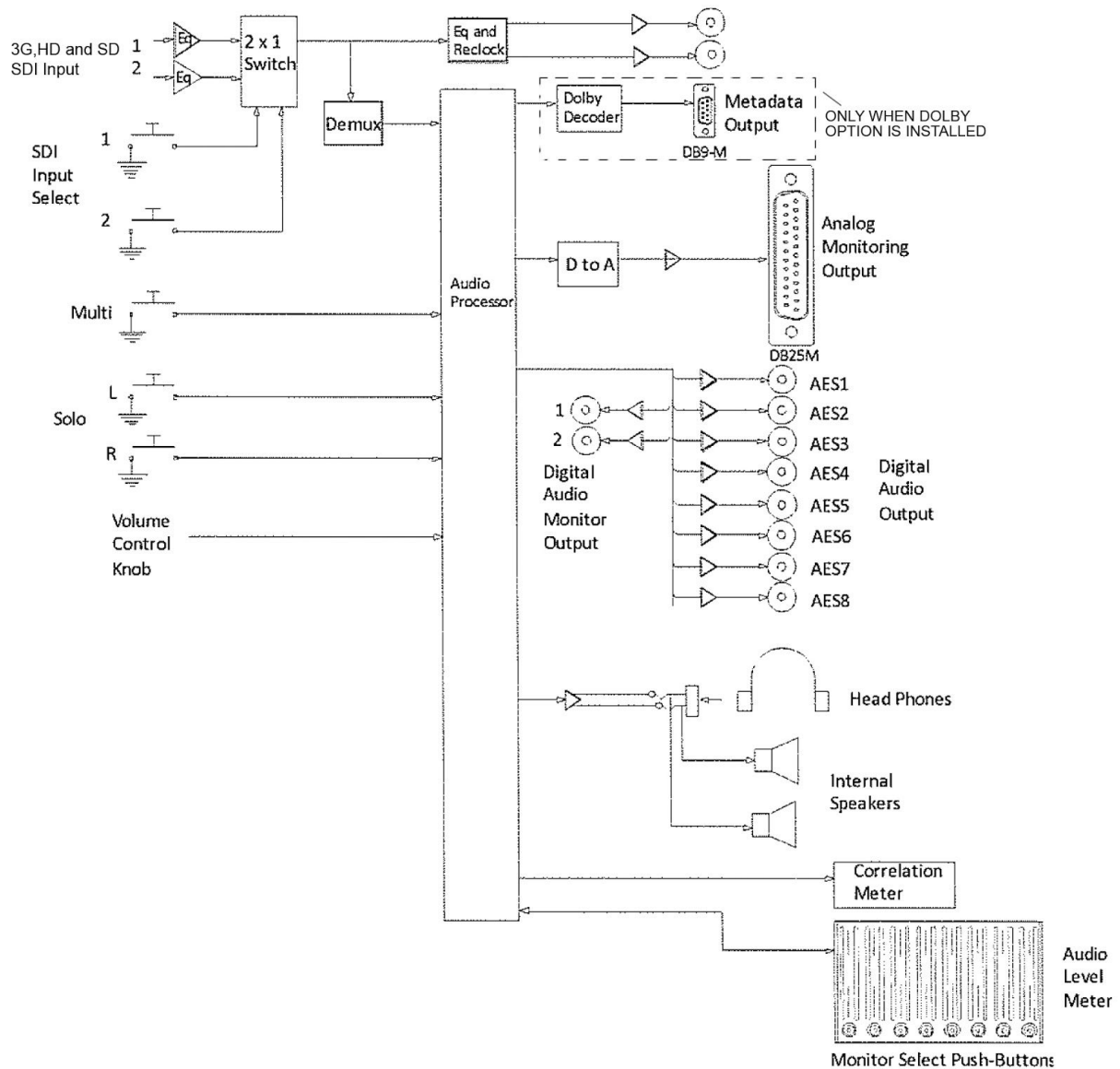

Figure 5.1-1 System Block Diagram

5.2 Connections

5.2.1 Analog Audio Connection (AUX1)

The analog audio connector is a DB25 male connector. Table 5.2-2 describes the analog output pin configuration.



Pin Description	Pin #
Analog 1A +	1
Analog 1A -	14
Analog 1B +	2
Analog 1B -	15
Analog 2A +	3
Analog 2A -	16
Analog 2B +	4
Analog 2B -	17
Analog 3A +	5
Analog 3A -	18
Analog 3B +	6
Analog 3B -	19
Analog 4A +	11
Analog 4A -	23
Analog 4B +	12
Analog 4B -	24
Ground	25, 13, 8, 20, 7

Table 5.2-2 Analog Audio Output Pin Configuration

5.2.2 Metadata Connection (only on optional Dolby-installed AMS16-2AEM model)

The Metadata connector is a nine pin DB9-M male connector. Refer to Table 5.2-2 for the pin configuration.



Pin Description	Pin #
TX A Asynchronous Data Out -	8
TX B Asynchronous Data Out +	3
Ground	1, 4, 6, 9

Table 5.2-3 Metadata Output Pin Configuration

5.3 Specifications Summary

Analog Output	
Frequency Response	1.5 dBU change from 20Hz – 20kHz
Impedance	60 Ω balanced
Max Output @ 0dBFS & 1kHz in	23.5 dBU
Noise	Less than -70dBU
THD	Less than 0.05%
Type	DB25 Male
AES/EBU Outputs	
Impedance	75 Ω Unbalanced
Level	2.5V p-p terminated
Max Output	0 dBFS
Noise	Less than -100 dBFS
Standard	AES3ID-1995
THD	Less than 0.001%
Type	BNC Female
Headset Jack	
Type	Tip Ring Sleeve (TRS)
Metadata Output (AMS16-2AEM only)	
Type	DB9 Male
Power	
AC Supply	90 – 230 VAC, 50-60 Hz
Average Consumption	38.5 Watt
Max Consumption	110 Watt
SDI Input / Output (re-clocked)	
Formats	
SD-SDI	525-270, 625-270
HD-SDI	1920 x 1080: 60, 59.94, 50, 29.97, 24, 23.98 Hz 1280 x 720: 60, 59.94 Hz

Impedance	75 Ω
Level	0.8 V p-p
Standards	SD-SDI as per SMPTE 259M HD-SDI as per SMPTE 292M 3G-SDI as per SMPTE 424M
Type	BNC Female
Dimension (W x D x H)	17 7/16" x 12 5/8" x 3 1/2" 44.3cm x 32.06cm x 8.89cm
Rack Size	2U
Weight	4.7 kg

WARRANTY

All Ward-Beck Systems Ltd. products are warranted against defective materials and workmanship for a period of one year from the date of shipment.

Ward-Beck Systems Ltd. will repair or replace, at its option and without charge, all said products or parts thereof which upon factory inspection prove to be defective during the warranty period, provided that:

1. The original serial numbers are intact and have not been tampered with.
2. The purchaser shall return any equipment or parts thereof to Ward-Beck Systems Ltd. only after obtaining prior authorization and shipping instructions from the factory. (Ward-Beck Systems Ltd. reserves the right to inspect or repair equipment on the purchaser's premises).
3. The purchaser assumes the obligation for all expenses in connection with the shipping and return of such goods, once authorization has been obtained.

This warranty does not cover items normally considered expendable, such as fuses and lamps.

This warranty does not cover damages caused by misuse, accident, neglect, unauthorized alteration, repair by unauthorized personnel, or damage caused by an act of God, war, or civil insurrection.

In no event shall Ward-Beck Systems Ltd. be liable for consequential damages. Ward-Beck Systems Ltd. shall have the rights to final determination as to the application of this warranty.

Ward-Beck Systems Ltd. reserves the right, at any time and without notice, to make changes in its equipment, components, specifications or designs, as may be warranted by progress in state-of-the-art technology.

Ward-Beck Systems Ltd. reserves the right to make design changes, additions to, and improvements in its products, without obligation to install such revisions in products previously manufactured.

The warranty set forth herein is in lieu of all other warranties expressed or implied, including the warranties of merchantability and fitness.

WARD-BECK SYSTEMS LTD.
945 Middlefield Road, Unit 9, Toronto, Ontario M1V 5E1
V 416 335 5999 F 416 335 5202 Toll-Free 800 771 2556
Website: www.ward-beck.com
E-Mail: sales@ward-beck.com

