

D6203A

OPENGear ANALOG TO AES/EBU DIGITAL AUDIO CONVERTER

User Manual

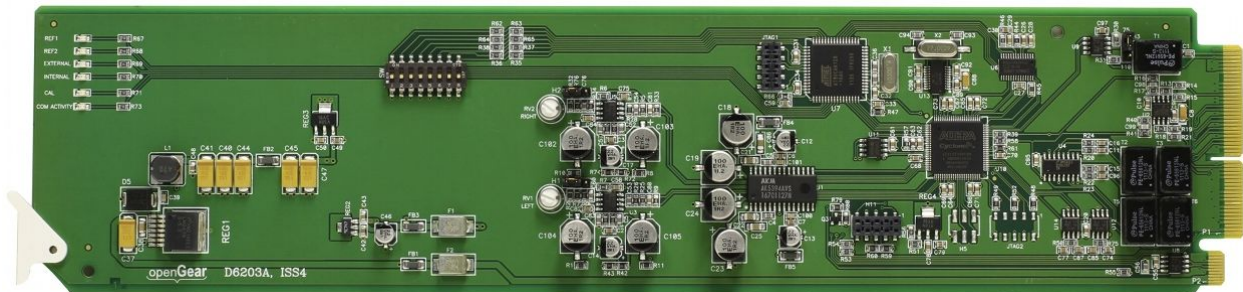

by Ward-Beck Systems

Rev: Jan.01 2015

Ward-Beck Part Number: D6203A

- Document Issue: 1
- Printed in Canada

The information contained in this User Manual is subject to change without notice or obligation.

Copyright

©2015 Ward-Beck Systems Ltd. All rights reserved.

Contents of this publication may not be reproduced in any form without the written permission of Ward-Beck Systems Ltd. Reproduction or reverse engineering of copyrighted software is prohibited.

Notice

The material in this manual is furnished for informational use only. It is subject to change without notice and should not be construed as a commitment by Ward-Beck Systems Ltd. Ward-Beck Systems Ltd. assumes no responsibility or liability for errors or inaccuracies that may appear in this manual.

Trademark



is a registered trademark of Ross Video Limited.



is a registered trademark of Ward-Beck Systems Ltd.

All other product names and any registered and unregistered trademarks mentioned in this manual are used for identification purposes only and remain the exclusive property of their respective owners.

Important Regulatory and Safety Notices

Before using this product and any associated equipment, refer to the “Important Safety Instructions” listed below so as to avoid personnel injury and to prevent product damage. Products may require specific equipment, and /or installation procedures be carried out to satisfy certain regulatory compliance requirements. Notices have been included in this publication to call attention to these Specific requirements.

Symbols Meanings



This symbol on the equipment refers you to important operating and maintenance (servicing) instructions within the Product Manual Documentation. Failure to heed this information may present a major risk of damage or injury to persons or equipment.



Warning

The symbol with the word “**Warning**” within the equipment manual indicates a potentially hazardous situation, which if not avoided, could result in death or serious injury.



Caution

The symbol with the word “**Caution**” within the equipment manual indicates a potentially hazardous situation, which if not avoided, may result in minor or moderate injury. It may also be used to alert against unsafe practices.



Notice

The symbol with the word “**Notice**” within the equipment manual indicates a situation, which if not avoided, may result in major or minor equipment damage or a situation which could place the equipment in a non-compliant operating state.



ESD Susceptibility

This symbol is used to alert the user that an electrical or electronic device or assembly is susceptible to damage from an ESD event.

Important Safety Instructions



Caution

This product is intended to be a component product of the openGear 8000 series frame. Refer to the openGear 8000 series frame User Manual for important safety instructions regarding the proper installation and safe operation of the frame as well as it's component products.



Warning

Certain parts of this equipment namely the power supply area still present a safety hazard, with the power switch in the OFF position. To avoid electrical shock, disconnect all A/C power cords from the chassis' rear appliance connectors before servicing this area.



Warning

Service barriers within this product are intended to protect the operator and service personnel from hazardous voltages. For continued safety, replace all barriers after any servicing.

This product contains safety critical parts, which if incorrectly replaced may present a risk of fire or electrical shock. Components contained within the product's power supplies and power supply area, are not intended to be customer serviced and should be returned to the factory for repair.

To reduce the risk of fire, replacement fuses must be the same type and rating.

Only use attachments/accessories specified by the manufacturer.

EMC Notices

US FCC Part 15

This equipment has been tested and found to comply with the limits for a class A Digital device, pursuant to part 15 of the FCC Rules. These limits are designed to provide reasonable protection against harmful interference when the equipment is operated in a commercial environment. This equipment generates, uses, and can radiate radio frequency energy and, if not installed and used in accordance with the instruction manual, may cause harmful interference to radio communications. Operation of this equipment in a residential area is likely to cause harmful interference in which case users will be required to correct the interference at their own expense.



Notice

Changes or modifications to this equipment not expressly approved by Ward-Beck Systems Ltd. could void the user's authority to operate this equipment.

CANADA

This Class "A" digital apparatus complies with Canadian ICES-003.

Cet appareil numérique de classe "A" est conforme à la norme NMB-003 du Canada.

EUROPE

This equipment is in compliance with the essential requirements and other relevant provisions of **CE Directive 93/68/EEC**.

INTERNATIONAL

This equipment has been tested to **CISPR 22:1997** along with amendments **A1:2000** and **A2:2002** and found to comply with the limits for a Class A Digital device.



Notice

This is a Class A product. In domestic environments this product may cause radio interference in which case the user may have to take adequate measures.

Maintenance/User Serviceable Parts

Routine maintenance to this openGear product is not required. This product contains no user serviceable parts. If the module does not appear to be working properly, please contact Technical Support using the numbers listed under the "Contact Us" section on the last page of this manual. All openGear products are covered by a generous 5-year warranty and will be repaired without charge for materials or labor within this period. See the "Warranty and Repair Policy" section in this manual for details.

Environmental Information

The equipment that you purchased required the extraction and use of natural resources for its production. It may contain hazardous substances that could impact health and the environment.

To avoid the potential release of those substances into the environment and to diminish the need for the extraction of natural resources, Ward-Beck Systems Ltd. encourages you to use the appropriate take-back systems. These systems will reuse or recycle most of the materials from your end-of-life equipment in an environmentally friendly and health conscious manner.

The crossed-out wheeled bin symbol invites you to use these systems.

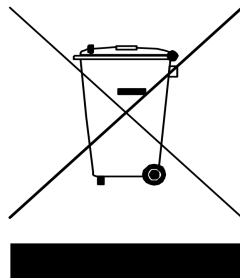

If you need more information on the collection, reuse, and recycling systems, please contact your local or regional waste administration.

Introduction

Overview

The D6203A is an analog to AES/EBU digital audio converter designed for broadcast use. It provides digital to analog audio conversion along with AES/EBU signal distribution.

The D6203A supports audio sampling frequencies from 30kHz to 192 kHz. It converts the incoming stereo analog audio signal to a AES/EBU digital audio signal using 24 bit conversion technology.

The D6203A is housed in the openGear OG3-FR-C series frames.

Functional Block Diagram

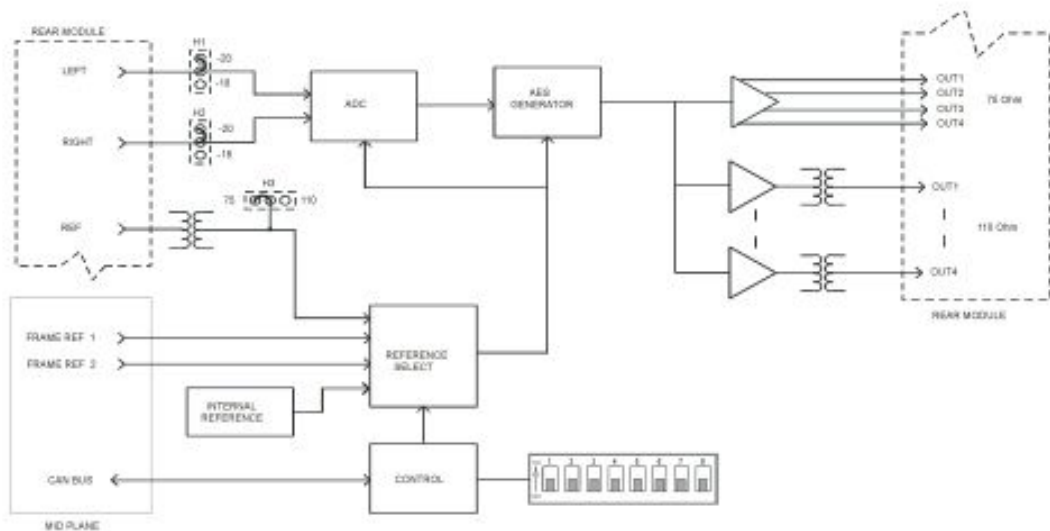

Figure 1. Simplified Block Diagram of the D6203A Functions

Features

The following features make the D6203A the best solution for analog to digital audio conversion.

- Converts analog audio to AES/EBU digital audio and provides AES/EBU signal distribution
- Can synchronize to frame, external or internally generated reference signals
- Internal clock generates audio sampling frequencies from 32kHz to 192 kHz
- 24 bit technology provides the highest quality signal conversion
- Suitable for 75 or 110 Ohm environments (select proper rear module)
- Higher density with up to 20 cards in a OG3-FR-C frame
- 5 year warranty
- Fits openGear OG3-FR-C series frames

Documentation Terms

The following terms are used throughout this guide:

- “**Frame**” refers to the **OG3-FR-C** frame that houses the **D6203A** card.
- “**Operator**” and “**User**” refer to the person who uses the **D6203A**.
- “**Board**”, and “**Card**” refer to the **D6203A** card itself, including all components and switches.

Installation and Setup

Static Discharge

Whenever handling the D6203A and other related equipment, please observe all static discharge precautions as described in the following note:



Static discharge can cause serious damage to sensitive semiconductor devices. Avoid handling circuit boards in high static environments such as carpeted areas, and when wearing synthetic fiber clothing. Always exercise proper grounding precautions when working on circuit boards and related equipment.

Unpacking

Unpack each D6203A you received from the shipping container, and check the contents against the packing list to ensure that all items are included. If any items are missing or damaged, contact your sales representative or Ward-Beck Systems Ltd. directly.

Rear Module Options

There are four rear module options available from the D6203A analog to AES/EBU digital audio converter.

75 Ohm environments: On the 20 slot **OG3-FR-C** frame the T6302A rear module occupies two slots and provides I/O for one D6203A card. The T6302A provides one 75 Ohm AES/EBU external reference input, four 75 Ohm AES/EBU outputs on BNC type connectors and one stereo analog audio input on 3 pin Phoenix terminal block connectors. For higher density applications the T6402A rear module occupies two slots and provides I/O for two D6203A cards. The T6402A provides two 75 Ohm AES/EBU reference inputs, two 75 Ohm AES/EBU outputs for each card on BNC type connectors and one stereo analog audio input for each card on 3 pin Phoenix terminal block connectors.

110 Ohm environments: On the T6303A and T6403A rear modules all connections for balanced AES/EBU digital audio signals and analog audio signals are provided on 3 pin Phoenix terminal block connectors.

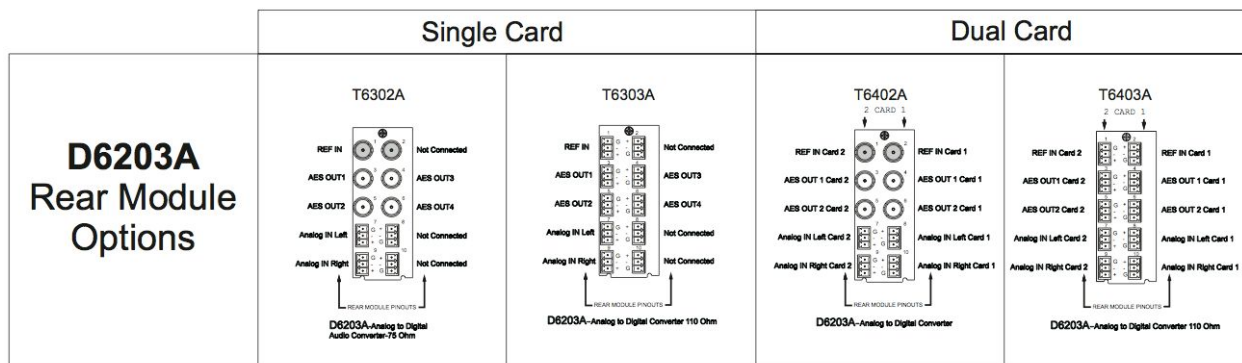

*WBS uses Phoenix Contact Pluggable Screw type connectors.

*The male portion is included with the purchase of rear module, but has not been drawn

Figure 2. Rear Module Terminations

Board Installation

Use the following procedure to install the D6203A in an openGear OG3-FR-C Series frame.

1. Refer to the User Manual of the openGear OG3-FR-C series frame to ensure that the frame is properly installed according to instructions.
2. When using the D6203A with the T6302A for maximum I/O please note that the even numbered slots are to be used. Plug the D6203A modules into slots 2,4,6,8,10,12,14,16,18, and 20 for a maximum of 10 cards. Slot 1 is the left most slot as you look into the frame from the front.
3. When using the D6203A with the T6402A for maximum density you may insert the card into any slot for up to 20 cards per frame.
4. After selecting the desired frame installation slot, hold the D6203A card by the edges and carefully align the card edges with the slots in the frame. Then fully insert the card into the frame until the rear connection plugs are properly seated on the midplane and rear module.

This completes the procedure for installing the D6203A in an openGear OG3-FR-C Series frame.

User Controls

User Control Diagram

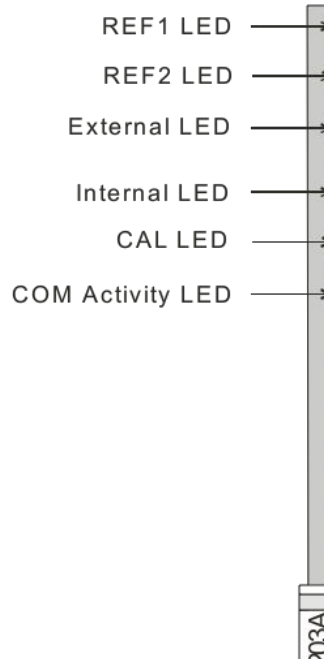

Figure 3. Card-edge User Controls

LEDs

The front-edge of the card features LEDs that display the status of the input signals. Descriptions are provided in the following table:

LED	Color	Location	Display and Description
REF 1	Green	Top of the card	When on indicates that frame reference 1 is selected and the card is locked to that signal. When flashing it indicates that REF 1 is selected but the signal is missing or corrupted. (The card will automatically switch to the internal reference and the internal reference LED will turn on)
REF 2	Green	Second from the top	When on indicates that frame reference 2 is selected and the card is locked to that signal. When flashing it indicates that REF 2 is selected but the signal is missing or corrupted. (The card will automatically switch to the internal reference and the internal reference LED will turn on)
External	Green	Third from the top	When on indicates that external reference is selected and the card is locked to that signal. When flashing it indicates that External Ref is selected but the signal is missing or corrupted. (The card will automatically switch to the internal reference and the internal reference LED will turn on)
Internal	Yellow	Fourth from the top	When on indicates that internal reference is selected either through dip switch selection or automatically and the card is locked to the internal reference (see above)
CAL	Red	Fifth from the top	When on indicates that the sampling frequency has changed and the card is self calibrating (very short duration)
COM Activity	Green	Sixth from the top	When on indicates that communications on the CAN bus is operating properly

Table 1. Status LED Descriptions

DIP Switch Settings

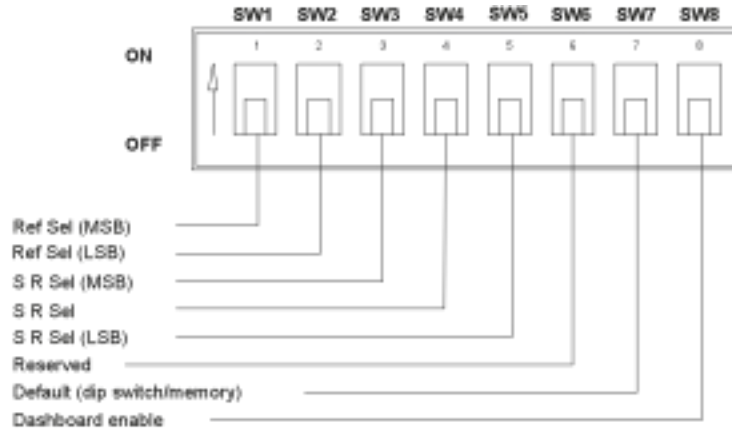

Figure 4. DIP Switch Controls

Table 1 Reference Selection

#	Ref Sel (MSB)	Ref Sel (LSB)	
1	OFF	OFF	Frame Ref 1
2	OFF	ON	Frame Ref 2
3	ON	OFF	External Ref (rear module)
4	ON	ON	Internal Ref

Table 2 Internal Sample Rate (SR) Ref set

#	Ref Sel (MSB)	Ref Sel (LSB)		
1	OFF	OFF	OFF	32 kHz
2	OFF	OFF	ON	44.1 kHz
3	OFF	ON	OFF	48 kHz
4	OFF	ON	ON	96 kHz
5	ON	X	X	192 kHz

Default (power up default parameter settings)

‘ON’ Get card parameters from non volatile memory, ignore dip switch settings.
(Configurable with Dashboard Control system)

‘OFF’ Get card parameters from the Dip switch.

Dashboard Enable

‘ON’ Only card status is available on Dashboard, users are prevented from changing parameters.

‘OFF’ Normal operation, users have full access to the cards parameters.

Technical Specifications

ANALOG INPUT

Input Level	+ 4 dBu
Input Impedance	>20 kOhms
Frequency Response	+/- 0.2 dB, 20 Hz to 20 kHz
Noise (un-weighted)	-84 dBu, 20 Hz to 20 kHz
THD+N	<0.01%
Stereo Separation	100 dB, 20 Hz to 20 kHz

DIGITAL OUTPUT

Resolution	24 Bit
Output Level	1 V p-p nominal unbalanced
Output Impedance	75 Ohm unbalanced 110 Ohm balanced
Sampling Frequency Range	32 kHz to 192 kHz
Jitter	Less than 5 ns

GENERAL

Power Requirements	+12 V, 4 Watts, MAX
Dimensions	3.025" high x 12.800" deep
Weight	approx. 0.115 kg (0.252 lbs)

NOTE: Ward-Beck Systems Ltd. reserves the right to change performance specifications without prior notice.

Warranty and Repair Policy

The openGear D6203A is warranted to be free of any defect with respect to performance, quality, reliability, and workmanship for a period of FIVE (5) years from the date of shipment from our factory. In the event that your openGear D6203A proves to be defective in any way during this warranty period, Ward-Beck Systems Ltd. reserves the right to repair or replace this piece of equipment with a unit of equal or superior performance characteristics.

Should you find that this openGear D6203A has failed after your warranty period has expired, we will repair your defective product should suitable replacement components be available. You, the owner, will bear any labor and/or part costs incurred in the repair or refurbishment of said equipment beyond the FIVE (5) year warranty period.

In no event shall Ward-Beck Systems be liable for direct, indirect, special, incidental, or consequential damages (including loss of profits) incurred by the use of this product. Implied warranties are expressly limited to the duration of this warranty.

This openGear D6203A User Manual provides all pertinent information for the safe installation and operation of your openGear Product. Ward-Beck policy dictates that all repairs to the openGear D6203A are to be conducted only by an authorized Ward-Beck Systems factory representative. Therefore, any unauthorized attempt to repair this product, by anyone other than an authorized Ward-Beck Systems factory representative, will automatically void the warranty. Please contact Ward-Beck Technical Support for more information.

In Case of Problems

Should any problem arise with your openGear D6203A, please contact the Ward-Beck Technical Support Department. (Contact information is supplied at the end of this publication.)

A Return Material Authorization number (RMA) will be issued to you, as well as specific shipping instructions, should you wish our factory to repair your openGear D6203A. If required, a temporary replacement module will be made available at a nominal charge. Any shipping costs incurred will be the responsibility of you, the customer. All products shipped to you from Ward-Beck Systems Ltd. will be shipped collect.

The Ward-Beck Technical Support Department will continue to provide advice on any product manufactured by Ward-Beck Systems, beyond the warranty period without charge, for the life of the equipment.

WARD-BECK SYSTEMS LTD.
945 Middlefield Road, Unit 9, Toronto, Ontario M1V 5E1
V 416 335 5999 F 416 335 5202 Toll-Free 800 771 2556
Website: www.ward-beck.com
E-Mail: sales@ward-beck.com

Ordering Information

Standard Equipment

- D6203A Analog to AES/EBU Digital Audio Converter 75 Ohm

Optional Equipment

- D6203AUM Analog to AES/EBU Digital Audio Converter 75 Ohm User Manual (additional User Manual)
- T6302A Single Card Rear Module (for installation into OG3-FR--C frame for maximum I/O)
- T6402A Dual Card Rear Module (for installation into OG3-FR-C frame for maximum density)
- OG3-FR-C Digital Products Frame and Power Supply with Cooling Fans (2RU, holds up to 20 cards)

Your D6203A Analog to AES/EBU Digital Audio Converter is a part of the openGear family of products. Ward-Beck offers a full line of openGear terminal equipment including distribution, conversion, monitoring, muxing, demuxing and processing of AES/EBU and HD/SD-SDI as well as analog audio and video products.