

M6205A-3G

OPENGear HD/SD-SDI 3G EMBEDDED AUDIO PROCESSOR W/LEVEL TRIM, AND CHANNEL SWAP, SHUFFLE AND REPLACEMENT

User Manual

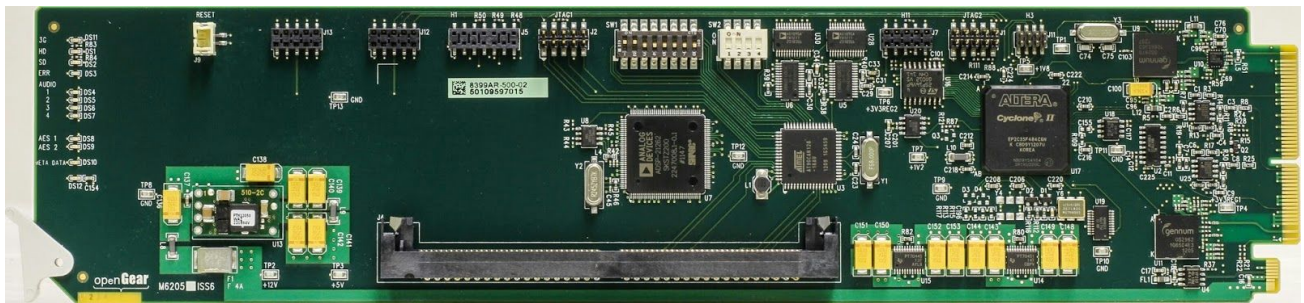

By Ward-Beck Systems

Rev:Jan.01 2015

Ward-Beck Part Number: M6205A-3G

- Document Issue: 1
- Printed in Canada

The information contained in this User Manual is subject to change without notice or obligation.

Copyright

©2015 Ward-Beck Systems Ltd. All rights reserved.

Contents of this publication may not be reproduced in any form without the written permission of Ward-Beck Systems Ltd. Reproduction or reverse engineering of copyrighted software is prohibited.

Notice

The material in this manual is furnished for informational use only. It is subject to change without notice and should not be construed as a commitment by Ward-Beck Systems Ltd. Ward-Beck Systems Ltd. assumes no responsibility or liability for errors or inaccuracies that may appear in this manual.

Trademark



is a registered trademark of Ross Video Limited.



is a registered trademark of Ward-Beck Systems Ltd.

All other product names and any registered and unregistered trademarks mentioned in this manual are used for identification purposes only and remain the exclusive property of their respective owners.

Important Regulatory and Safety Notices

Before using this product and any associated equipment, refer to the “Important Safety Instructions” listed below so as to avoid personnel injury and to prevent product damage. Products may require specific equipment, and /or installation procedures be carried out to satisfy certain regulatory compliance requirements. Notices have been included in this publication to call attention to these Specific requirements.

Symbols Meanings



This symbol on the equipment refers you to important operating and maintenance (servicing) instructions within the Product Manual Documentation. Failure to heed this information may present a major risk of damage or injury to persons or equipment.



Warning

The symbol with the word “**Warning**” within the equipment manual indicates a potentially hazardous situation, which if not avoided, could result in death or serious injury.



Caution

The symbol with the word “**Caution**” within the equipment manual indicates a potentially hazardous situation, which if not avoided, may result in minor or moderate injury. It may also be used to alert against unsafe practices.



Notice

The symbol with the word “**Notice**” within the equipment manual indicates a situation, which if not avoided, may result in major or minor equipment damage or a situation which could place the equipment in a non-compliant operating state.



ESD Susceptibility

This symbol is used to alert the user that an electrical or electronic device or assembly is susceptible to damage from an ESD event.

Important Safety Instructions



Caution

This product is intended to be a component product of the openGear 8000 series frame. Refer to the openGear 8000 series frame User Manual for important safety instructions regarding the proper installation and safe operation of the frame as well as it's component products.



Warning

Certain parts of this equipment namely the power supply area still present a safety hazard, with the power switch in the OFF position. To avoid electrical shock, disconnect all A/C power cords from the chassis' rear appliance connectors before servicing this area.



Warning

Service barriers within this product are intended to protect the operator and service personnel from hazardous voltages. For continued safety, replace all barriers after any servicing.

This product contains safety critical parts, which if incorrectly replaced may present a risk of fire or electrical shock. Components contained within the product's power supplies and power supply area, are not intended to be customer serviced and should be returned to the factory for repair.

To reduce the risk of fire, replacement fuses must be the same type and rating.

Only use attachments/accessories specified by the manufacturer.

EMC Notices

US FCC Part 15

This equipment has been tested and found to comply with the limits for a class A Digital device, pursuant to part 15 of the FCC Rules. These limits are designed to provide reasonable protection against harmful interference when the equipment is operated in a commercial environment. This equipment generates, uses, and can radiate radio frequency energy and, if not installed and used in accordance with the instruction manual, may cause harmful interference to radio communications. Operation of this equipment in a residential area is likely to cause harmful interference in which case users will be required to correct the interference at their own expense.



Notice

Changes or modifications to this equipment not expressly approved by Ward-Beck Systems Ltd. could void the user's authority to operate this equipment.

CANADA

This Class "A" digital apparatus complies with Canadian ICES-003.

Cet appareil numérique de classe "A" est conforme à la norme NMB-003 du Canada.

EUROPE

This equipment is in compliance with the essential requirements and other relevant provisions of **CE Directive 93/68/EEC**.

INTERNATIONAL

This equipment has been tested to **CISPR 22:1997** along with amendments **A1:2000** and **A2:2002** and found to comply with the limits for a Class A Digital device.



Notice

This is a Class A product. In domestic environments this product may cause radio interference in which case the user may have to take adequate measures.

Maintenance/User Serviceable Parts

Routine maintenance to this openGear product is not required. This product contains no user serviceable parts. If the module does not appear to be working properly, please contact Technical Support using the numbers listed under the "Contact Us" section on the last page of this manual. All openGear products are covered by a generous 5-year warranty and will be repaired without charge for materials or labor within this period. See the "Warranty and Repair Policy" section in this manual for details.

Environmental Information

The equipment that you purchased required the extraction and use of natural resources for its production. It may contain hazardous substances that could impact health and the environment.

To avoid the potential release of those substances into the environment and to diminish the need for the extraction of natural resources, Ward-Beck Systems Ltd. encourages you to use the appropriate take-back systems. These systems will reuse or recycle most of the materials from your end-of-life equipment in an environmentally friendly and health conscious manner.

The crossed-out wheeled bin symbol invites you to use these systems.

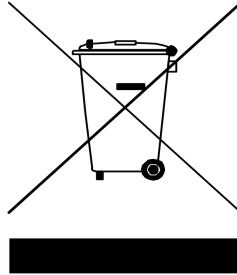

If you need more information on the collection, reuse, and recycling systems, please contact your local or regional waste administration.

Introduction

Overview

The M6205A-3G is a sophisticated audio processing platform card designed for broadcast use. It can extract and process up to 16 channels of audio embedded in a digital video stream. The M6205A-3G accepts 3G, HD-SDI and SD-SDI signals. In addition two AES inputs are provided to enable substitution of the embedded audio signals. The card may also be used as a one group embedder. Functions of the card include channel shuffling, channel replacement or substitution, and mixing. Several task specific processors for DTS and Dolby signals may be plugged into the 72 pin SIMM socket on the card. The optional processors include:

- DTS Neural Loudness Control
- DTS MultiMerge
- DTS UpMix
- Dolby E/AC3 Decoding

The M6205A-3G extracts, processes, and re-embeds the audio providing two SDI outputs with the embedded processed audio. In addition the card provides AES copies of the processed audio. The M6205A-3G complies with SMPTE 272M, SMPTE 299M, and SMPTE 424M standards. Cable equalization and reclocking techniques enable the M6205A-3G to recover the incoming 3G, SD-SDI or HD-SDI signal reliably. The M6205A-3G is housed in the openGear OG3-FR-C series frames.

Features

- Automatic detection of video input format
- Cable equalization and data reclocking on the incoming 3G, HD-SDI or SD-SDI signal
- Card edge LED's indicating video presence, audio presence and card status
- Dolby compliant sample rate converters automatically turn off to allow seamless Dolby embedding
- 5 year warranty
- Fits openGear OG3-FR-C series frames

Documentation Terms

The following terms are used throughout this guide:

- **“Frame”** refers to the **OG3-FR-C** frame that houses the **M6205A-3G** card.
- **“Operator”** and **“User”** refer to the person who uses the **M6205A-3G**.
- **“Board”**, and **“Card”** refer to the **M6205A-3G** card itself, including all components and switches.
- **“Daughter Card”** refers to the optional processing card that can be plugged into the 72 pin SIMM socket.

Functional Block Diagram

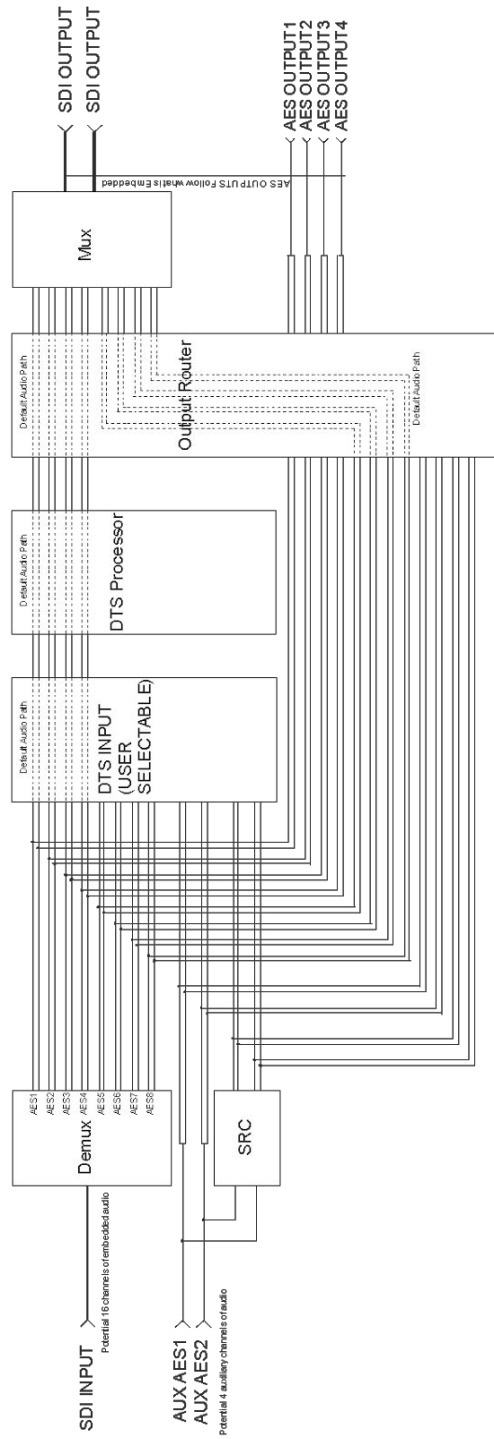

Figure 1. Simplified Block Diagram of the M6205A-3G Functions

Installation and Setup

Static Discharge

Whenever handling the M6205A-3G and other related equipment, please observe all static discharge precautions as described in the following note:



Static discharge can cause serious damage to sensitive semiconductor devices. Avoid handling circuit boards in high static environments such as carpeted areas, and when wearing synthetic fiber clothing. Always exercise proper grounding precautions when working on circuit boards and related equipment.

Unpacking

Unpack each M6205A-3G you received from the shipping container, and check the contents against the packing list to ensure that all items are included. If any items are missing or damaged, contact your sales representative or Ward-Beck Systems Ltd. directly.

Rear Module Options

The T6301A-3G provides an 3G/HD/SD-SDI input and up to 4 demuxed, and processed AES/EBU outputs on 75 Ohm BNC connectors. The T6301A-3G also provides two 3G/HD/SD-SDI outputs with processed embedded audio present. Other variations of rear module may be made available upon discussion with the factory.

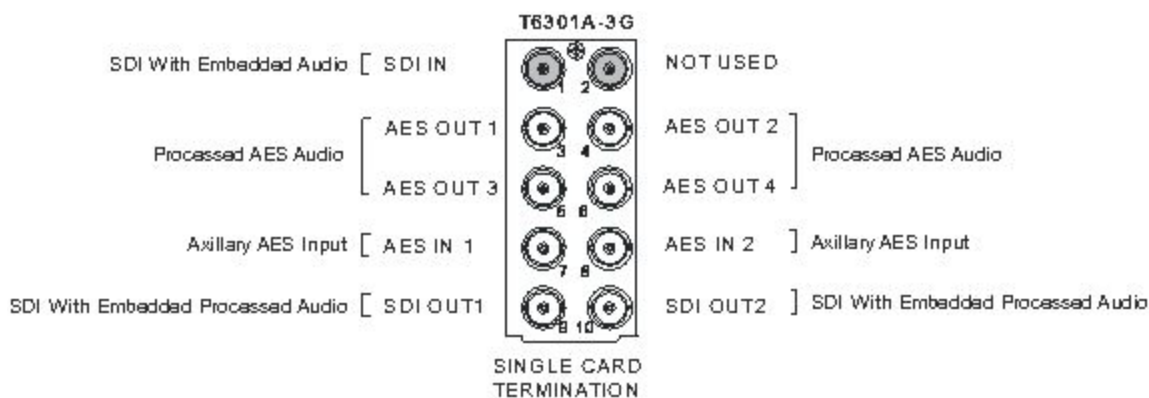

Figure 2. Rear Modules

Board Installation

Use the following procedure to install the M6205A-3G in an openGear OG3-FR-C Series frame.

1. Refer to the User Manual of the openGear OG3-FR-C series frame to ensure that the frame is properly installed according to instructions.
2. When using the M6205A-3G with the OG3-FR-C frame, please note that the even numbered slots are to be used. Plug the M6205A-3G modules into slots 2,4,6,8,10,12,14,16,18, and 20 for a maximum of 10 cards. Slot 1 is the left most slot as you look into the frame from the front.
3. After selecting the desired frame installation slot, hold the M6205A-3G card by the edges and carefully align the card edges with the slots in the frame. Then fully insert the card into the frame until the rear connection plugs are properly seated on the mid-plane and on the rear module.

This completes the procedure for installing the M6205A-3G in an openGear OG3-FR-C Series frame.

User Controls

User Control Diagram

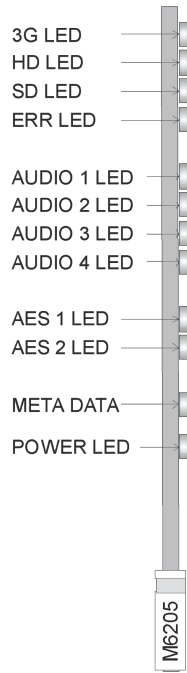

Figure 3. Card-edge User Controls

LEDs

The front-edge of the card features LEDs that display the status of the input signals. As selections are made in the menus, (refer to the subsequent chapter for complete menu descriptions), the LEDs display the status of the input signals. Descriptions are provided in the following table:

LED	Color	Location	Display and Description
3G	Green	Top of the card	When on there is a valid 3G signal at the input.
HD	Green	2 nd from the top	When on there is a valid HD-SDI signal at the input.
SD	Green	3 rd from the top	When on there is a valid SD-SDI signal at the input.
ERR	Red	4 th from the top	When on a valid 3G, SD-SDI or HD-SDI signal is not present.
AUDIO 1	Yellow	5 th from the top	When on this indicates there is audio present in Group 1 embedded in the SDI input.
AUDIO 2	Yellow	6 th from the top	When on this indicates there is audio present in Group 2 embedded in the SDI input.

AUDIO 3	Yellow	7 th from the top	When on this indicates there is audio present in Group 3 embedded in the SDI input.
AUDIO 4	Yellow	8 th from the top	When on this indicates there is audio present in Group 4 embedded in the SDI input.
AES1	Yellow	9 th from the top	When on this indicates there is audio present on AES1 input.
AES2	Yellow	10 th from the top	When on this indicates there is audio present on AES2 input.
META DATA	Green	11 th from the top	Reserved
POWER	Green	12 th from the top	When on this indicates that the card is powered.

Table 1: Status LED Descriptions

Remote Dashboard Section

General Information

This card may be monitored by a remote computer through Dashboard version 2.2.1 or higher. This free configuration monitoring software is available to openGear users at www.opengear.tv and is compatible with operating systems such as Windows, Linux and Mac.

The Dashboard control system is built on Ethernet and TCP/IP, allowing remote access across both LAN and WAN architectures. Multiple frames and cards can be connected to multiple control and monitoring stations at once.

Basic Dashboard Control

The five sections pertinent to card control monitoring are shown in figure 8 below:

1. Basic Tree View
2. Card Communication Summary
3. Card Info Menu
- 4 & 5. Card Status Menu
6. General Tasks

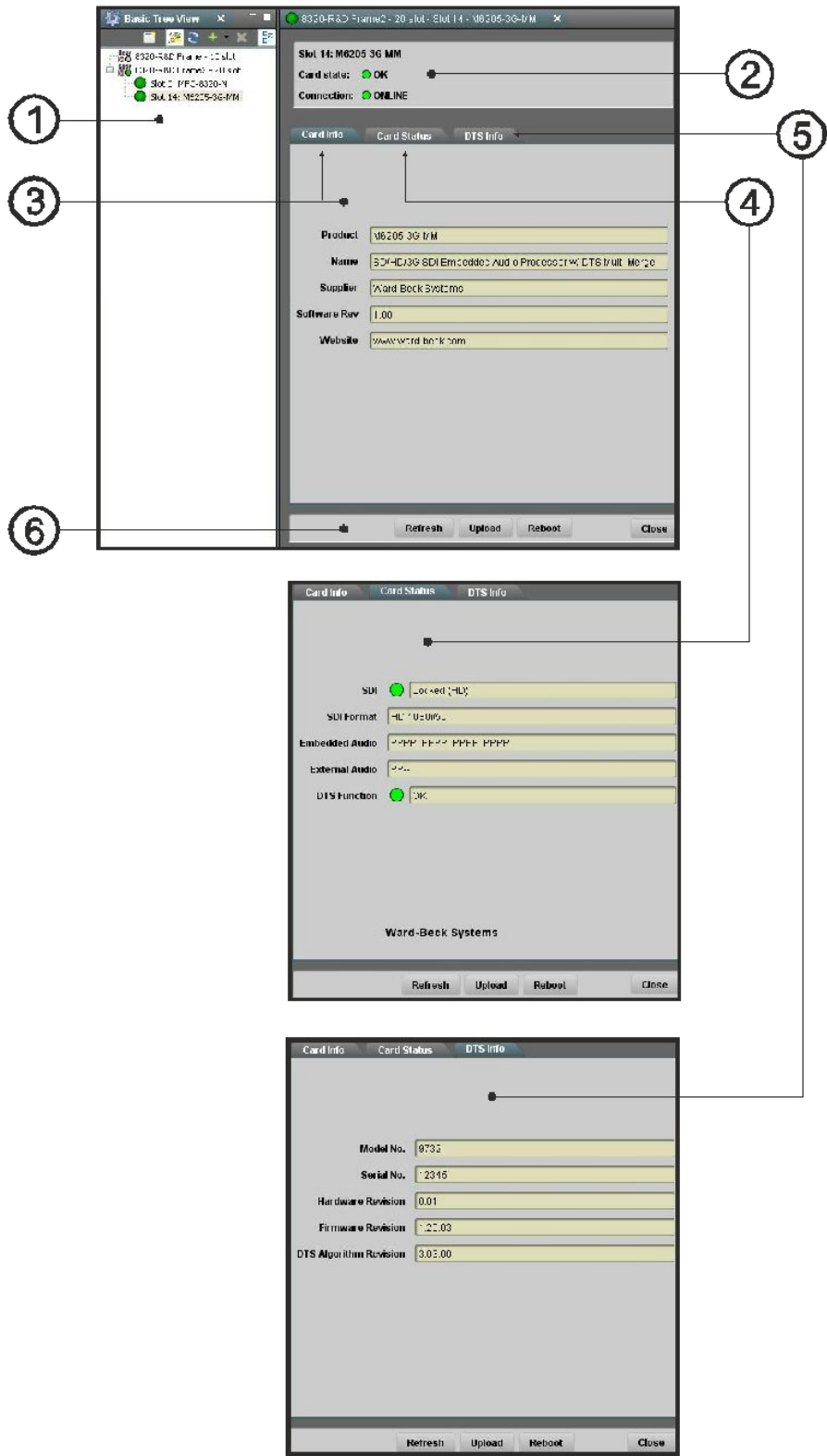

Figure 4 Dashboard Remote Monitoring User Interface

①

Basic Tree View

The basic tree view lists all frames connected remotely to Dashboard. Double click the frame corresponding to the M6205A-3G card. An expanded list of all cards connected to the frame will appear. Locate the card labeled M6205A-3G and double click to open the control monitoring panel for this card.

②

Card Communication Summary

MENU	ITEM	DISPLAY	DESCRIPTION
Card Communication Summary (Read Only)		M6205A-3G	Product identification code
	Card State	(Green Dot) Ok	Card is functioning properly and appropriate signals are connected
		(Red Dot) SDI Unlocked	SDI signal is not present
		(Red Dot) Optional Card Error	Optional daughterboard is not functioning properly
		(Grey Dot) No connection to device	Communication between card and Dashboard is unavailable
	Connection	(Green Dot) Online	Communication between card, frame and Dashboard is available
		(Red Dot) Offline	Communication between card and Dashboard is unavailable
		(Grey Dot) No connection to frame	Communication between frame and Dashboard is unavailable

Table 2. communication summary

③

Card Info Tab

MENU	ITEM	DISPLAY	DESCRIPTION
Card Info (Read Only)	Product	M6205A-3G+(optional process)	Product identification code
	Name	MD-SDI Embedded Audio Processor with optional hardware.	Product functional description
	Manufacturer	Ward-Beck Systems Ltd.	Manufacturer of the card
	Software Rev.	###	Three digit software revision code
	Web site	www.ward-beck.com	Manufacturer's web address

Table 3. Card Tab info

④

Card Status Tab

MENU	ITEM	DISPLAY	DESCRIPTION
Status (Read Only)	SDI	Green Dot- (3G, HD, SD)	Locked to source, and gives signal type
		Red Dot	Unable to lock to SDI input
	SDI Format		Provides additional information about the input signal type.
	Embedded Audio	-, C, D, E, P	Provides Embedded Audio Type Information for Each Channel - – No Audio C – Unidentifiable Compressed
	External Audio	-, C, D, E, P	D – Dolby Digital E – Dolby E P - PCM
	Optional Hardware	(Green Dot) Ok	Optional hardware installed and enabled
		(Green Dot) N/A	Optional hardware disabled
		(Red Dot) Error	Optional hardware not installed or not functioning properly

Table 4. Card Status Tab

5 Optional Hardware Tab

MENU	ITEM	DISPLAY
Status (Read Only)	Model Number	Shows the model number of the optional hardware
	Serial Number	Shows the serial number of the optional hardware
	Hardware revision	Shows the hardware version number
	Firmware revision	Show the firmware revision number
	DTS algorithm revision	Shows the revision number of the DTS algorithm installed

Table 5. Optional Hardware Tab

6 General Tasks

MENU	DISPLAY	DESCRIPTION
General Tasks (Button)	REFRESH	When pressed, refreshes the dashboard display.
	UPLOAD	Used for future firmware upgrades.
	REBOOT	When pressed, reboots the card.
	CLOSE	When pressed, closes monitor control window.

Table 6. General Tasks Tab

M6205A-3G Output Routing Section

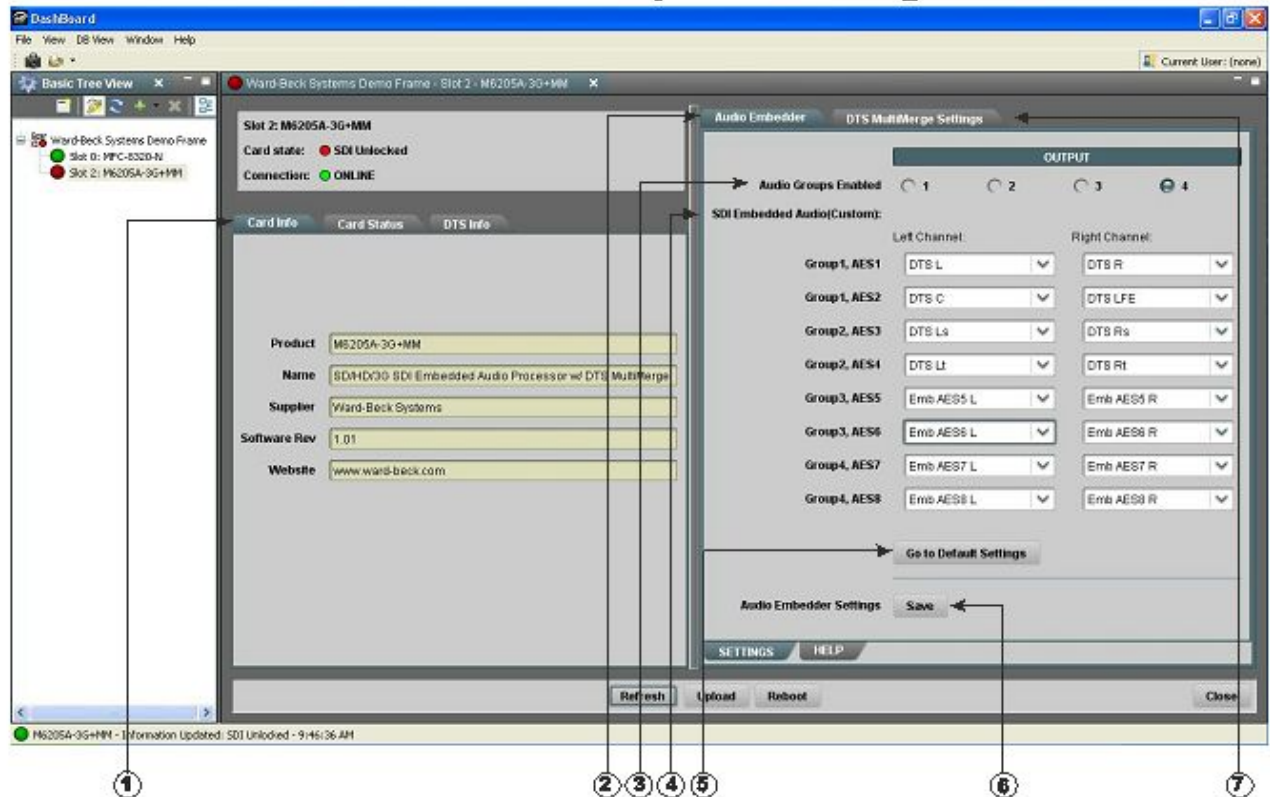

Figure 5. M6205A-3G General Dashboard Screenshot

- 1 General M6205A-3G Section**
 -The general M6205A-3G section includes three tabs, they are Card Info, Cards Status, and DTS info. Please see the pages above for more information.
- 2 Audio Routing Section**
- 3 Audio Groups Enabled**
 -Determines the number of audio groups embedded in the output stream
- 4 SDI Embedded Audio**
 -Selects the 16 audio channels for output SDI stream, choices are:
 -Any 8 of the processed audio channels from the DTS daughter card
 -Any 4 of the external audio channels, with or without sample rate conversion engaged.
 -Any of the 16 embedded input audio channels
- 5 Go to Default / Go to Custom toggle**
 -Switches between the default audio path, and unlocking custom routing of the audio path.
 -Default audio choices are:
 -AES1 through AES4 are taken from the output of the daughter card, AES5 to AES8 are passed through to the output.
- 6 Save Audio Routing Settings:**
 Saves the following parameters:
 -Audio Groups Enabled
 -SDI Embedded Audio
- 7 Optional Equipment Tab**
 -Please see the optional equipment section

Optional Equipment Section

The M6205A-3G has a 72 pin SIMM card connector slot. This slot allows the user to add additional audio processing cards. The following sections will include specific instructions for M6205A-3G cards with optional equipment installed:

M6205A-3G may be optionally equipped with the following:

- +MultiMerge
- +UpMix
- +NLC
- +Dolby E/AC3 Decode

M6205A-3G+MultiMerge Manual DIP Switch Settings



Output of Audio Groups			MultiMerge Bypass		Upmix Low Frequency Filter				Power Up Initialization Settings		Dashboard Control		DownMix Low Frequency Filter				Aux Stereo Input Select	
DIP-1	DIP-2	Audio Groups Enabled	DIP-3	Output Mode	DIP-4	DIP-5	DIP-6	Upmix LFE Cutoff	DIP-7	Init Settings	DIP-8	Change Settings by Dashboard	DIP-9	DIP-10	DIP-11	Downmix LFE Cutoff	DIP-12	Input Source
OFF	OFF	1	OFF	In-Line	OFF	OFF	OFF	0Hz	OFF	From Dipswitch	OFF	YES	OFF	OFF	OFF	Pass Through	OFF	AES1~3 (Stereo or 5.1)
OFF	ON	1-2	ON	Bypass	OFF	OFF	ON	60Hz	ON	From EEPROM	ON	NO	OFF	OFF	ON	60Hz	ON	AES4 (Stereo)
ON	OFF	1-3			OFF	ON	OFF	80Hz					OFF	ON	OFF	80Hz		
ON	ON	1-4			OFF	ON	ON	100Hz					OFF	ON	ON	100Hz		
					ON	OFF	OFF	120Hz					ON	OFF	OFF	120Hz		
					ON	OFF	ON	140Hz					ON	OFF	ON	140Hz		
					ON	ON	OFF	RESERVED					ON	ON	OFF	RESERVED		
					ON	ON	ON	RESERVED					ON	ON	ON	RESERVED		

Table 7. M6205A-3G+MultiMerge Dip Settings

M6205A-3G+MultiMerge Remote Dashboard Settings

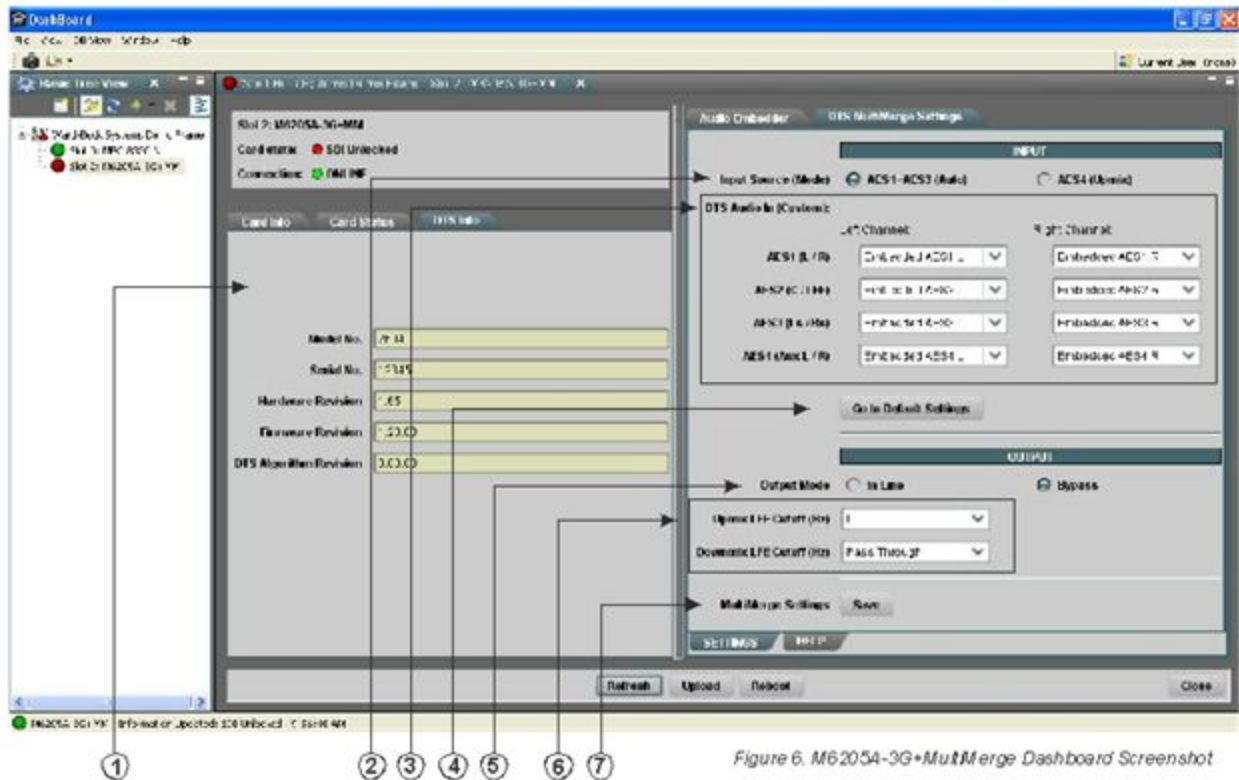

Figure 6. M6205A-3G+MultiMerge Dashboard Screenshot

1 General M6205A-3G Section

-Please refer to the Remote Dashboard M6205A-3G Section

2 Input Source (Mode):

Selects which AES pair is fed into the card:

-AES1~AES3 will automatically upmix or downmix depending on which inputs are connected.

-If a source is connected to AES 1, the card will automatically upmix the audio. If a source is connected on AES inputs 1 through 3, the card will automatically downmix the audio.

-AES4 is the auxiliary audio input. The card will upmix audio from this input when routed properly.

3 DTS Audio In

-The user may select which 8 audio channels are to be processed by the DTS MultiMerge processing card.

-The user has the potential to select from the 16 embedded audio channels from the SDI input, or from the 4 external audio channels from the AES inputs. The user may also choose to have the external audio channels sample rate converted prior to being processed by the DTS MultiMerge card.

4 Go to Default / Go to Custom toggle

-Configures the 8 input channels of the DTS MultiMerge to the default choices. The default choices are as shown in the above Dashboard screenshot.

5 Output Mode:

Selects if MultiMerge is active, or in-active

-In-Line = MultiMerge is active.

-Bypass = MultiMerge is in-active.

6a UpMix LFE cutoff (Hz):

-Controls the cutoff frequency of the lowpass filter for the LFE channel when the card is UpMixing.

6b DownMix LFE Cutoff (Hz):

-Controls the cutoff frequency of the lowpass filter for the LFE channel when the card is DownMixing.

7 Save MultiMerge Settings:

Saves the following parameters:

-Input Source

-DTS Audio In

-Output Mode

-UpMix LFE Cutoff

-DownMix LFE Cutoff

Simplified Block Diagram of Audio Path within MultiMerge

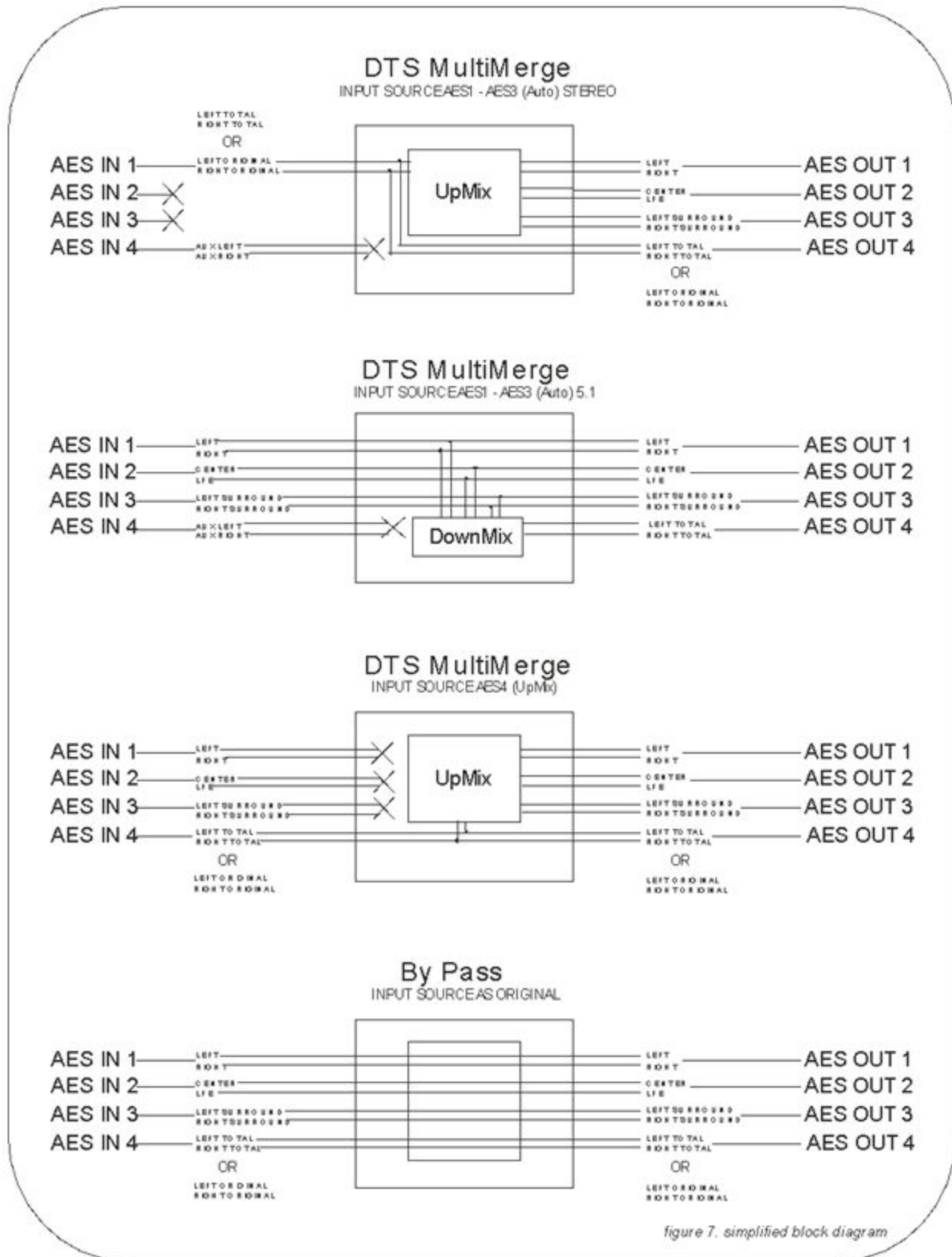

figure 7. simplified block diagram

Manual DIP Switch Settings M6205A-3G+UpMix



Output of Audio Groups			UpMix Output Selection			Low Frequency Effects Mute	Power Up Initialization Settings	Dashboard Control	AES Group to be UpMixed						
DIP-1	DIP-2	Audio Groups Enabled	DIP-3	DIP-4	DIP-5	Output Mode	DIP-6	LFE Mode	DIP-7	Init Settings	DIP-8	Change Settings by Dashboard	DIP-9	DIP-10	Input Selector
OFF	OFF	1	OFF	OFF	OFF	BYPASS	OFF	Normal	OFF	From Dipswitch	OFF	YES	OFF	OFF	AES1
OFF	ON	1-2	OFF	OFF	ON	STEREO	ON	Mute	ON	From EEPROM	ON	NO	OFF	ON	AES2
ON	OFF	1-3	OFF	ON	OFF	2.1							ON	OFF	AES3
ON	ON	1-4	OFF	ON	ON	3.1							ON	ON	AES4
			ON	OFF	OFF	4.1									
			ON	OFF	ON	5.1									
			ON	ON	OFF	6.1									
			ON	ON	ON	7.1									

Table 8. M6205A-3G+MultiMerge Dip Settings

Simplified Block Diagram of Audio Path within UpMix

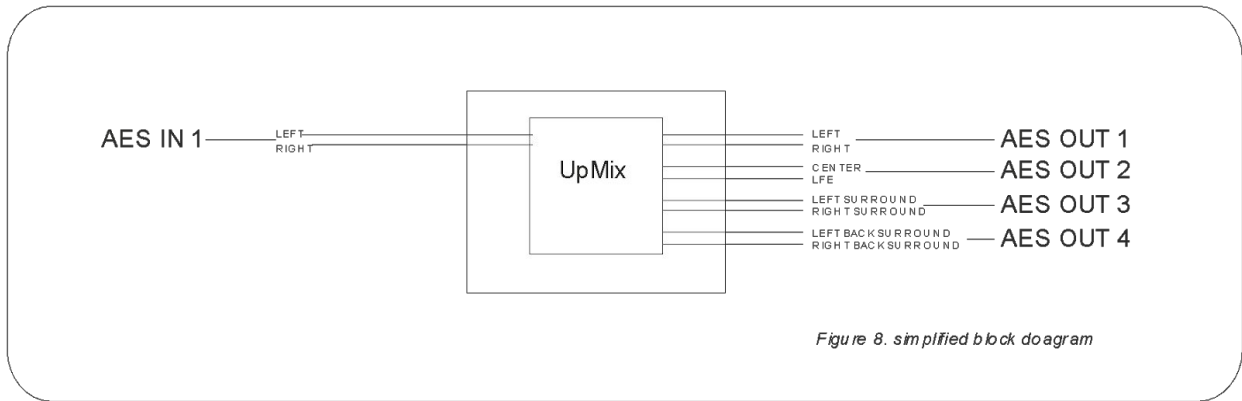

Figure 8. simplified block diagram

M6205A-3G+NLC5.1 Manual DIP Switch Settings

DIP-1	DIP-2	Audio Groups Enabled	DIP-4	DIP-5	Preset	DIP-3	Output Mode	DIP-7	Init Settings	DIP-8	Change Settings by Dashboard	DIP-9	DIP-10	DIP-11	DIP-12	Target Level (dB)
OFF	OFF	1	OFF	OFF	Light	OFF	In-Line	OFF	From Dipswitch	OFF	YES	OFF	OFF	OFF	OFF	-35
OFF	ON	2	OFF	ON	Medium	ON	Bypass	ON	From EEPROM	ON	NO	OFF	OFF	ON	ON	-34
ON	OFF	3	ON	OFF	Aggressive							OFF	OFF	ON	OFF	-33
ON	ON	4	ON	ON	User							OFF	OFF	ON	ON	-32
												OFF	ON	OFF	OFF	-31
												OFF	ON	OFF	ON	-30
												OFF	ON	ON	OFF	-29
												OFF	ON	ON	ON	-28
												ON	OFF	OFF	OFF	-27
												ON	OFF	OFF	ON	-26
												ON	OFF	ON	OFF	-25
												ON	OFF	ON	ON	-24
												ON	ON	OFF	OFF	-23
												ON	ON	OFF	ON	-22
												ON	ON	ON	OFF	-21
												ON	ON	ON	ON	-20

Table 9. M6205A-3G+NLC5.1 Dip Settings

M6205-3G+NLC5.1 Remote Dashboard Settings Tab

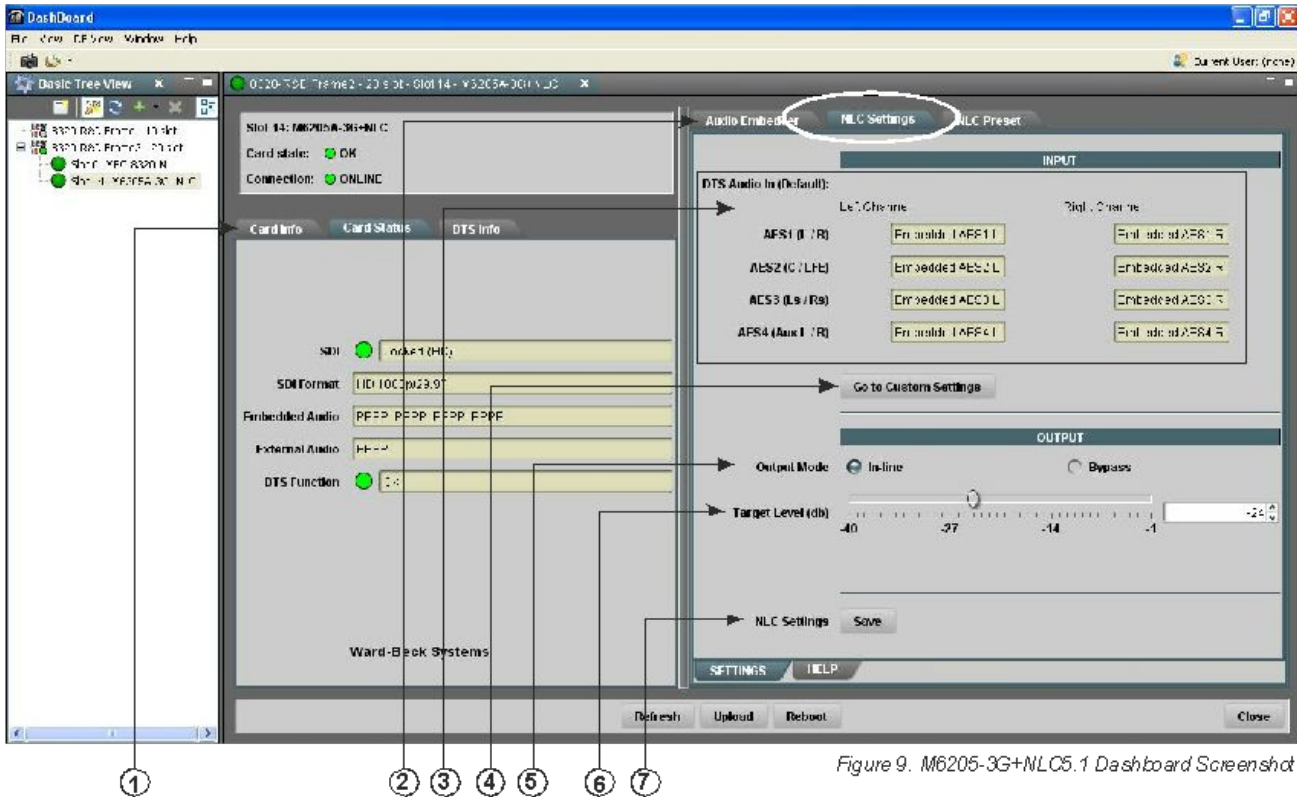

Figure 9. M6205-3G+NLC5.1 Dashboard Screenshot

① General M6205-3G Section

-Please refer to the Remote Dashboard M6205-3G Section

② Audio Embedder Section

-Please refer to the Audio Output Routing section of the manual.

③ DTS Audio In: (Default):

Selects 8 input audio channels to the DTS card, choices are:
 -16 embedded input audio channels
 -4 external audio channels with sample rate converter on, or sample rate converter off.

④ Go to Default/Custom:

Switches between Default and Custom Settings for DTS Audio In:

-Default: DTS input channels are set to factory default choices:

AES 1 (Left / Right)
 AES 2 (Center / LFE)
 AES 3 (Left Surround / Right Surround)
 AES 4 (Aux Left / Aux Right)

-Custom: DTS input channels are set to user choices.

-The user has the potential to select from the 16 embedded audio channels from the SDI input, or from the 4 external audio channels from the AES inputs. The user may also choose to have the external audio channels sample rate converted prior to being processed by the DTS +NLC5.1 card.

⑤ Output Mode:

Selects if NLC5.1 is active, or in-active
 -In-Line = NLC5.1 is active.
 -Bypass = NLC5.1 is in-active.

⑥ Target Level:

-Set the target Loudness Level of the Output.

⑦ Save DTS NLC5.1 Settings:

Saves the following parameters:
 -DTS Audio In
 -Output Mode
 -Target Level

M6205-3G+NLC5.1 Remote Dashboard Presets Tab

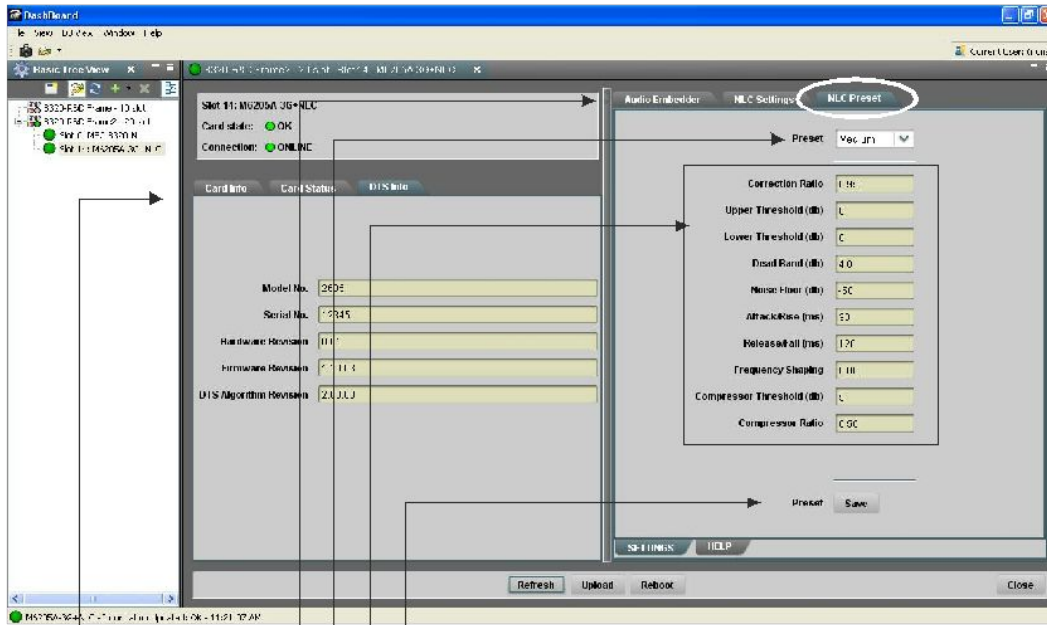

Figure 10. M6205-3G+NLC5.1 Dashboard Screenshot

1 General M6205-3G Section

-Please refer to the Remote Dashboard M6205-3G Section

2 Audio Embedder Section

-Please refer to the Audio Output Routing section of the manual.

3 Presets:

Selects different profiles to control the loudness

- Light
- Medium
- Aggressive

-User: selectable parameters

Changing the *Preset* drop down menu to user unlocks the preset values slider.

4 Preset Values:

Correction Ratio: Sets the amount of gain or attenuation that is applies for each 1dB difference between input and target level.

Upper Threshold: Sets the minimum required difference between input and target level to start applying attenuation.

Lower Threshold: Sets the minimum required difference between input and target level to start applying gain.

Dead Band: Sets a symmetrical window around the target level, any input that falls within that window is considered allowable.

Noise Floor: Sets the level of noise, any input lower than this level is considered noise and will not be processed.

Attack/Rise: Controls how fast the processor responds to any sharp increase in input level.

Release/Fall: Controls how fast the processor responds to any sharp decrease in input level.

Compressor Threshold: Sets the minimum required short term peak of the input above the target level to start applying compression.

Compressor Ratio: Sets the amount of compression that is applied for each 1 dB of short term peak above the threshold.

5 Save DTS NLC5.1 Settings:

Saves the following parameters:

- DTS Audio In
- Output Mode
- Target Level

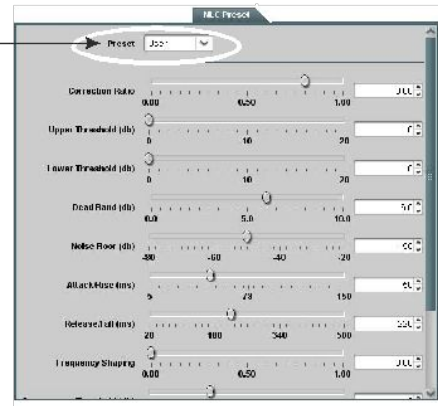

Technical Specifications

SDI INPUT

Number of Inputs	1
Connector	BNC 75 Ohm
Signals Supported	SMPTE-259M (270Mbps) SMPTE-292M (1.485, 1.485/1.001Gbps) SMPTE-424M (2.970, 2.970/1.001 Gbps)
Formats Supported	SD: 486i59.94, 576i50 HD: 1080i60, 1080i59.94, 1080i50 1080p30, 1080p29.97, 1080p25, 1080p24, 1080p23.98 3G: 720p60, 720p59.94, 720p50, 720p30, 720p25, 720p24 Level A - 1080p60, 1080p59.94, 1080p50
Cable Length	SD: 400m Belden 1694A HD: 170m Belden 1694A 3G: 80m Belden 1694

SDI OUTPUT

Number of Outputs	2
Connector	BNC 75 Ohm
Format	Follows Input
Cable Length	SD: 300m Belden 1694A HD: 215m Belden 1694A 3G: 80m Belden 1694A

AES Input

Number of Inputs	2
Connector	BNC 75 Ohm
Standard	AES-3id
Format	Up to 24 Bits Up to 192kHz with SRC On

AES Output

Number of Outputs	4
Connector	BNC 75 Ohm
Standard	AES-3id
Format	Up to 24 Bits 48 kHz

Power	12W Max
--------------	---------

**Specifications when used with the T6301A-3G Rear Module.
Ward-Beck Systems Ltd. reserves the right to change performance specifications without prior notice.*

Warranty and Repair Policy

The openGear M6205A-3G is warranted to be free of any defect with respect to performance, quality, reliability, and workmanship for a period of FIVE (5) years from the date of shipment from our factory. In the event that your openGear M6205A-3G proves to be defective in any way during this warranty period, Ward-Beck Systems Ltd. reserves the right to repair or replace this piece of equipment with a unit of equal or superior performance characteristics.

Should you find that this openGear M6205A-3G has failed after your warranty period has expired, we will repair your defective product should suitable replacement components be available. You, the owner, will bear any labor and/or part costs incurred in the repair or refurbishment of said equipment beyond the FIVE (5) year warranty period.

In no event shall Ward-Beck Systems be liable for direct, indirect, special, incidental, or consequential damages (including loss of profits) incurred by the use of this product. Implied warranties are expressly limited to the duration of this warranty.

This openGear M6205A-3G User Manual provides all pertinent information for the safe installation and operation of your openGear Product. Ward-Beck policy dictates that all repairs to the openGear M6205A-3G are to be conducted only by an authorized Ward-Beck Systems factory representative. Therefore, any unauthorized attempt to repair this product, by anyone other than an authorized Ward-Beck Systems factory representative, will automatically void the warranty. Please contact Ward-Beck Technical Support for more information.

In Case of Problems

Should any problem arise with your openGear M6205A-3G, please contact the Ward-Beck Technical Support Department. (Contact information is supplied at the end of this publication.)

A Return Material Authorization number (RMA) will be issued to you, as well as specific shipping instructions, should you wish our factory to repair your openGear M6205A-3G. If required, a temporary replacement module will be made available at a nominal charge. Any shipping costs incurred will be the responsibility of you, the customer. All products shipped to you from Ward-Beck Systems Ltd. will be shipped collect.

The Ward-Beck Technical Support Department will continue to provide advice on any product manufactured by Ward-Beck Systems, beyond the warranty period without charge, for the life of the equipment.

WARD-BECK SYSTEMS LTD.
945 Middlefield Road, Unit 9, Toronto, Ontario M1V 5E1
V 416 335 5999 F 416 335 5202 Toll-Free 800 771 2556
Website: www.ward-beck.com
E-Mail: sales@ward-beck.com

Ordering Information

Standard Equipment

- M6205A-3G HD/SD-SDI 3G Embedded Audio Processor

Optional Equipment

- M6205A-3GUM HD/SD-SDI 3G Embedded Audio Processor User Manual (additional User Manual)
- T6301A-3G 75 Ohm rear module for single card in OG3-FR-C frame
- OG3-FR-C Digital Products Frame and Power Supply with Cooling Fans (2RU, holds up to 20 cards)
- +MultiMerge - DTS MultiMerge daughterboard
- +UpMix - DTS UpMix daughterboard
- +NLC - DTS Neural Loudness control daughterboard

Your **M6205A-3G** HD/SD-SDI 3G Embedded Audio Processor is a part of the openGear family of products. Ward-Beck offers a full line of openGear terminal equipment including distribution, conversion, monitoring, muxing, demuxing and processing of AES/EBU and HD/SD-SDI as well as analog audio and video products.