

**Mobile Carts w/ Universal Flat Panel Mount**

Tuffy video carts bracket includes a **WFST Universal Mount**. With an exclusive counter-weight system.

Shelves are constructed with a injection molded thermoplastic resin. Will not chip, warp, rust or peel. There are two metal reinforcements molded into the 2" thick top shelf for extra strength.

Includes a 3-outlet UL listed electrical assembly with a 15 ft. cord. Electrical assembly is recessed to insure easy passage through doorways and other tight spots.

A set of silent roll, 4" full swivel ball bearing casters, two with locking brakes.

Locking steel cabinet panels fit firmly into the specially molded leg slots.

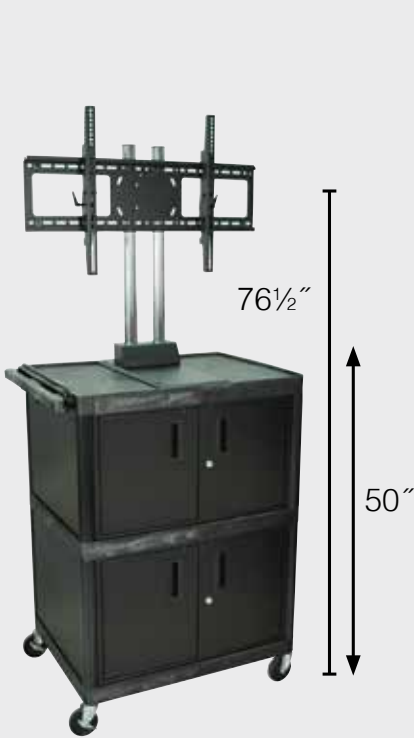

**WPTV50E**

  
Ships Via Truck Line



**WPTV44CE**



**WPTV44E**



**WPTV28CE**



**WPTV28E**

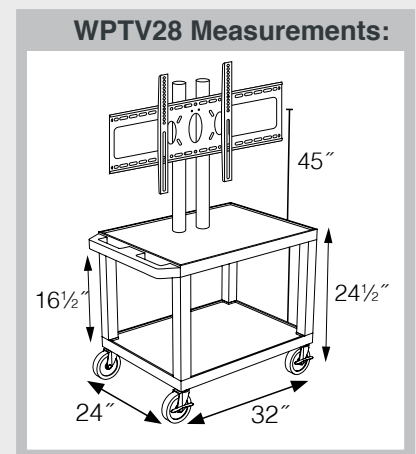
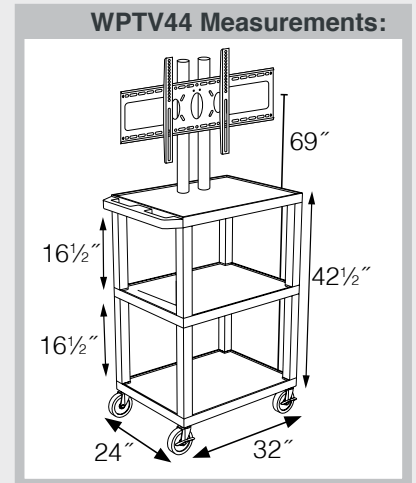

**\*Height is the measurement from the floor to mount center**