

AMP2-D8 Series™ 8 CHANNEL MONITOR WITH DOLBY® AC3

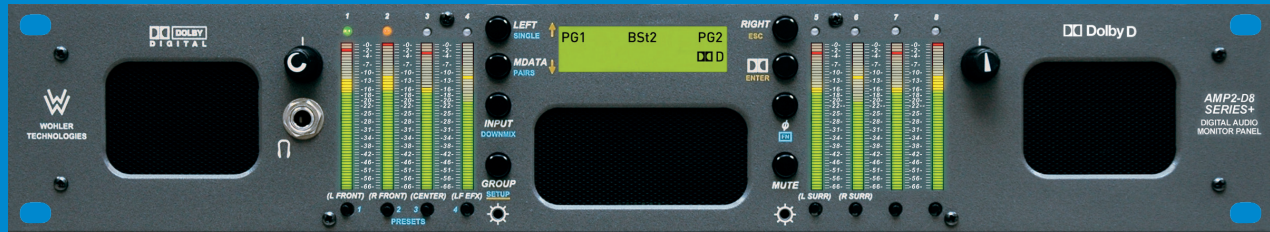

2RU in-rack audio monitor processes encoded, multi-channel audio from Dolby Digital® streams decoded from AES

The AMP2-D8 Series monitors (AMP2-D8DA and AMP2-D8-MDA) are 2RU in-rack audio monitors capable of outputting and/or displaying encoded, multi-channel audio (up to 8 channels) from Dolby Digital streams decoded from AES. The ability to switch seamlessly between encoded or discrete PCM sources, in addition to providing full, simultaneous demuxed output of the multi-channel source offers a significant new operational capability. The AMP2-D8 Series monitors audio from Dolby Digital (AC-3), 3G/HD/SD-SDI, AES/EBU and analog signal sources.

These units are ideal for use in VTR bays, mobile production vehicles, teleconferencing installations, multimedia systems, satellite links, cable TV facilities, and on-air radio studios. Extended HF response reveals potential problems with audio whine or hiss, and electronic rather than acoustic cancellation of bass frequencies provides positive audible detection of reversed polarity audio feeds. The sleek design provides optimally focused sound for operators in an ultra near field environment (1 to 3 ft.) with performance comparable to that of many separate monitor pairs without installation hassles and awkward speaker placements. This enables a higher SPL for the operator while reducing overall ambient sound and adjacent bay crosstalk.

Benefits:

- Supports decoding and playback of Dolby Digital bitstreams
- Select and assign a channel or channel pair to left, right or both speakers, or select a predefined downmix
- 4 presets let you change the entire system configuration with the press of a single button
- Thorough magnetic shielding allows placement next to sensitive equipment and video monitors

Features:

- Backlit LED screen displays phase, signal type, Dolby program, and more
- Eight 26-segment tri-color LED bar graphs display simultaneous VU and PPM
- Sum any combination of up to 8 channels to the left and/or right speakers and selected analog outputs
- Premium quality drivers and power amplifiers deliver excellent frequency response and low distortion
- Power 104dB SPL at 2 feet (0.6m)



AMP2-D8 Series TM 8 CHANNEL MONITOR WITH DOLBY® AC3

AMP2-D8DA 8 channel AES/Analog Audio Monitor with Dolby AC-3, 2RU

AMP2-D8-MDA 8 channel 3G/HD/SD-SDI Audio Monitor with Dolby AC-3, 2RU

Rear Panel Inputs/Outputs in red available only on model AMP2-D8-MDA

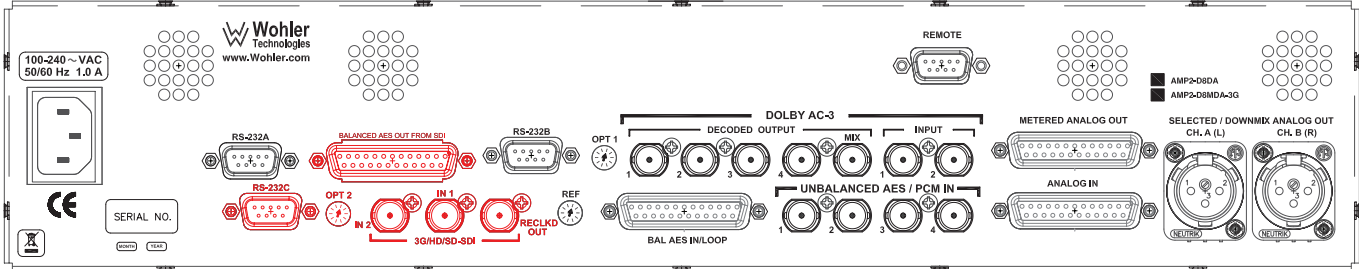

Block Diagram Inputs/Outputs in red available only on model AMP2-D8-MDA

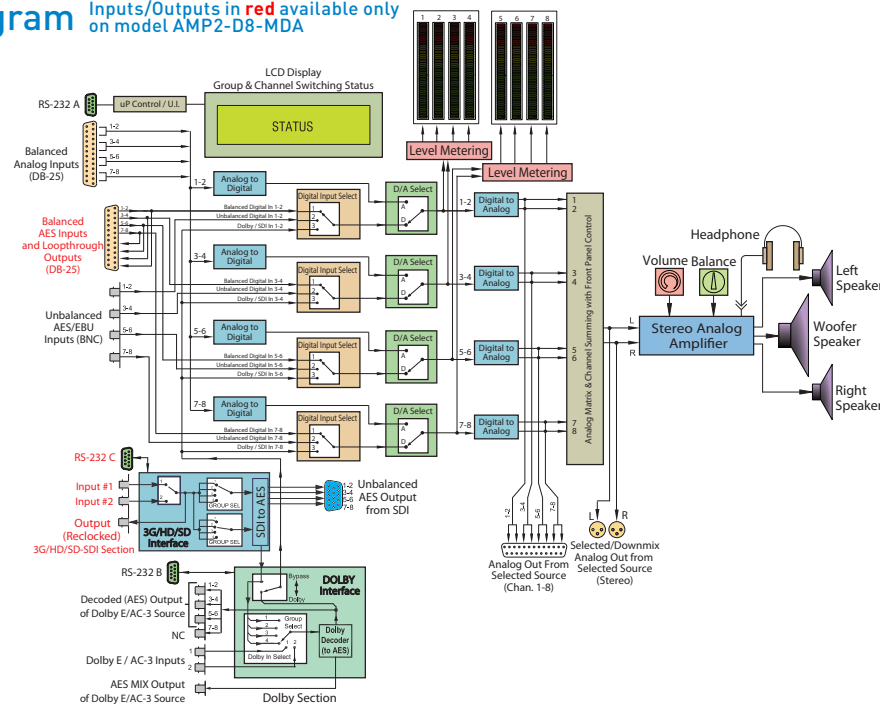

Specifications

View complete list of specifications online at www.wohler.com

Inputs	8 Balanced Analog Inputs (DB-25) 4 Unbalanced AES Input Pairs (BNC) 4 Balanced AES Input Pairs (DB-25) 2 HD/SD-SDI Inputs (BNC) (Available only with model AMP2-D8-MDA) 2 Dolby AC-3 Inputs (BNC)
Outputs	2 Balanced Analog Outputs (XLR) 8 Balanced Analog Loop-Through Outputs From Selected Source (DB-25) 4 Balanced AES Loop-Through Output Pairs (DB-25) 4 Balanced AES Outputs From SDI (DB-25) (Available only with model AMP2-D8-MDA) 1 HD/SD-SDI Reclocked Output (BNC) (Available only with model AMP2-D8-MDA) 4 Dolby AC-3 Decoded Outputs (BNC) 1 Unbalanced Aes Mix Output From Dolby Ac-3 (BNC)

Wohler Technologies, Inc.
 Worldwide Headquarters
 31055 Huntwood Avenue
 Hayward, CA 94544 USA
 Phone: +1 510 870 0810
 Fax: +1 510 870 0811
 Email: sales@wohler.com

Wohler Technologies/APAC
 45/F, The Lee Gardens
 33 Hysan Avenue
 Causeway Bay, Hong Kong
 Phone: +852 3180 2240
 Fax: +852 3180 2299
 Email: salesasia@wohler.com

Wohler Technologies/Australia
 PO Box 14
 South Hurstville
 NSW 2221, Australia
 Phone: +61 2 8005 1899
 Fax: +61 2 9547 0674
 Email: salesaustralia@wohler.com

Wohler Technologies/EMEA
 453 Stroude Road, Virginia Water
 Surrey GU25 4BU
 United Kingdom
 Phone: +44 (0) 2081 236 658
 Fax: +44 (0) 208 181 6500
 Email: salesemea@wohler.com