



Description

The AMP2A-10S provides self-powered, full-fidelity stereo audio monitoring in a compact two rack space cabinet. A front panel switch allows the operator to select one stereo source for monitoring and output from up to 10 stereo analog inputs (20 channels).

The AMP2A-10S features two 20-segment LED level meters showing VU or PPM for accurate level-metering. This unit contains three audiophile-quality drivers and three power amplifiers; two speakers and amplifiers reproduce midrange and high frequency information in stereo, while the third amp/driver combination handles summed LF information below the 500 Hz crossover point.

The unique design provides optimally focused sound for operators in an ultra near field (1 to 3 ft.) working environment and offers performance comparable to that of many separate monitor pairs, yet does so without the installation hassles, awkward speaker placements and “added-on” look. This provides for a

higher SPL for the operator while reducing overall ambient sound and adjacent bay crosstalk.

Excellent HF response reveals potential problems with audio whine or hiss and electronic rather than acoustic cancellation of bass frequencies provides positive audible detection of out-of-phase (reversed polarity) audio feeds. A headphone jack is provided on the front panel, usage automatically mutes the speakers. The front panel features an innovative LED Display of phase/polarity relationships. Output limiter circuits are incorporated to protect the speakers, and extensive magnetic shielding allows placement immediately adjacent to video monitors with no color impurities.

The AMP2A-10S is ideally suited for use in VTR bays, mobile production vehicles, teleconferencing installations, multimedia systems, satellite link and cable TV facilities, and on-air radio studios.

Features

Premium quality drivers

Twenty balanced analog Inputs (10 stereo, select 1)

Balanced analog output of selected stereo source

Powerful 104dB SPL at 2 feet (0.6m)

Two 20-segment tri-color level meters displaying VU or PPM

Order Part Number

AMP2-10S: 8100-0200

Excellent frequency response and low distortion

Innovative LED Display of Phase/Polarity Relationships

Headphone jack (mutes speakers)

Blowout proof speakers

Quick and simple installation

Benefits

Premium quality drivers provide superior reproduction.

Audible indication of phase/polarity problems provide instant information.

Thorough magnetic shielding allows placement next to video monitors

Focused sound reduces adjacent bay crosstalk.

Rear Panel

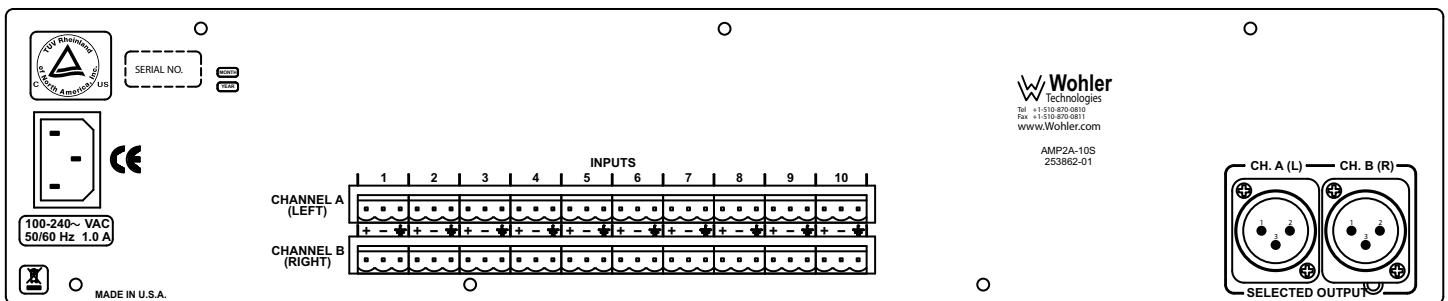

Physical Specifications

Dimensions (H x W x D)	3.5" x 19" x 12" (89 mm x 483 mm x 305 mm)
Shipping weight	21 lbs. (9.53 kg)
Space requirements	2RU in a standard 19" rack
Supplied accessories	AC external power unit/cord
Power connector	Attached external power unit plugs into standard U.S. outlet. Alternate power cables are available.
Power requirements	Power to the unit is 24V DC, 3.0 A. The external power supply then connects to mains power (100 to 240 VAC ± 10%, 50/60Hz.
Power consumption	45 W

Technical Specifications

Inputs	20 Phoenix (3-pin, male)
Outputs	2 selected out on XLR
Analog input impedance	40K Ω , balanced
Peak acoustic out (@ 2')	104 dB SPL
Power output	
RMS each side (4Ω):	14 W transient / 10 W continuous
RMS bass (4Ω):	35 W transient / 25 W continuous
Frequency response, 6th octave	80 Hz - 16 kHz \pm 5 dB (-10 dB @ 40 Hz, 20 kHz)
Input level for maximum output (volume full on)	0 dBv balanced
Hum and noise (analog)	Better than -68 dB below full output
Distortion, electrical	< 0.15% at any level below input threshold
Distortion, acoustic	6% or less at worst case frequencies above 120 Hz, including cabinet resonance; typically less than 1.5%
Input overload	+26 dBv balanced
Analog out S/N	>90 dB
Analog out THD	<0.008%
Level meter type	20-segment LED bar graph
Segment quantity	20
LED segment pitch	.01" (2.54 mm)
Bar graph length	2" (50.8 mm)
Meter dynamics	VU or PPM, selectable
Level gain	-6, 0, +4, +8 dBu, selectable
Dynamic range	44 dB
Midscale resolution	1 dB
Segment colors	Tricolor (green, amber, red)
Scale	+4 (peak) to -40 dB

Block Diagram

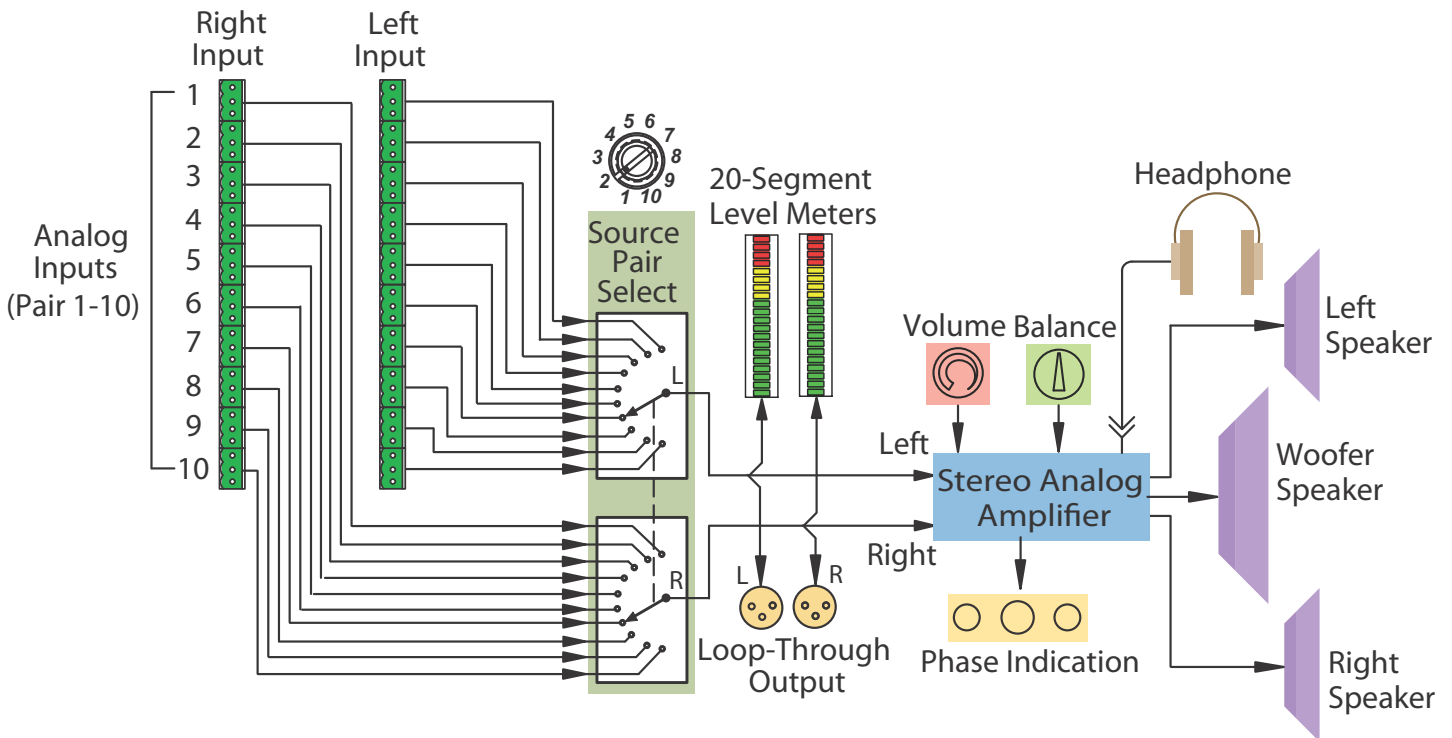

Contact

Wohler Technologies, Inc.
 31055 Huntwood Avenue
 Hayward, CA 94544 USA
 +1 888 5 WOHLER (Toll Free)
 +1 510 870-0810
 +1 510 870-0811 (fax)

Wohler Europe
 +33 970 440 253
 +33 1 77 72 59 99 (fax)
 sales@wohler.com
 www.wohler.com

Wohler Asia
 1704 Lucky Commercial Center
 103 Des Voeux Road West
 Sheung Wan, Hong Kong
 +852 2851 8325
 +852 2850 8182 (fax)